

Ninja® 300
Ninja® 300 ABS

Motorcycle
Assembly & Preparation
Manual



Foreword

In order to ship Kawasaki vehicles as efficiently as possible, they are partially disassembled before crating. Since some of the most commonly removed parts have a direct bearing on a vehicle's reliability and safety, conscientious pre-sale assembly and preparation becomes extremely important. Good setup procedures can prevent needless warranty claims and give customers a greater sense of confidence in Kawasaki and their Kawasaki Dealers.

This Assembly and Preparation Manual explains step by step procedures of the following items for the Kawasaki Ninja 300, Ninja 300 ABS.

1. Uncrating
2. Assembly
3. Preparation

The selling dealer assumes sole responsibility for any unauthorized modifications prior to sale. Refer to your Service Binder for any Service Bulletins specifying Factory Directed Modifications (Special Claims) which must be performed before the vehicle is ready for sale.

Whenever you see the following symbols heed their instructions! Always follow safe operating and maintenance practices.

DANGER

DANGER indicates a hazardous situation which, if not avoided, will result in death or serious injury.

WARNING

WARNING indicates a hazardous situation which, if not avoided, could result in death or serious injury.

NOTICE

NOTICE is used to address practices not related to personal injury.

NOTE

○*NOTE* indicates information that may help or guide you in the operation or service of the vehicle.

Kawasaki Heavy Industries, Ltd. accepts no liability for any inaccuracies or omissions in this publication, although every possible measure has been taken to make it as complete and accurate as possible. All procedures and specifications subject to change without notice.

Table of Contents

Uncrating	3
Opening Crate for Pattern A and C	3
Opening Crate for Pattern B	3
Parts Check for Pattern A	5
Parts Check for Pattern B	6
Parts Check for Pattern C	8
Assembly	10
Steering Stem Head Bolt for Pattern B	10
Handlebar for Pattern A and C	10
Cables, Harness and Hoses Routing	11
Front Brake Master Cylinder for Pattern B	12
Clutch Cable	12
Windshield and Rear View Mirrors (Left and Right)	12
Cap for Pattern B	13
Guard (Left and Right) for Pattern C	13
Single Seat Cover for Pattern C	13
Brake Disc Cleaning	14
Preparation	14
Battery Service	14
Front Brake	18
Rear Brake	20
Clutch Lever and Cable	21
Drive Chain	22
Rear Shock Absorber	23
Tire Air Pressures	23
Fuel	24
Coolant	24
Engine Oil (4-stroke)	25
Idle Speed Adjustment	26
Throttle Grip and Cable	26
Rear Brake Light Switch	27
Headlight Aim	27
Digital Meter	28
License Plate Mounting Holes	28
Fastener Check	30
Standard Torque Table	32
Test Ride the Motorcycle	32
A & P Check List	32

Uncrating

There are two types of crates which explained as Pattern A, B or C in this manual. Confirm your crate type and follow the each procedure below to setup.

Opening Crate for Pattern A and C

⚠ WARNING

Crates have sharp edges and may have nails or screws that can cause cuts and injury. Always wear protective gloves, boots and eye protection when uncrating to prevent injury.



MC03003B S

⚠ WARNING

The steel crate panel plates and fasteners have sharp edges. Always wear protective gloves, boots and eye protection when uncrating to prevent injury.



MC03004B S

- Clear a space about 6 m (20 ft) square to give yourself plenty of space to work.
- Place the crate upright on its base.
- Remove the cardboard cover.
- Remove the parts box.

NOTICE

When removing the crate bracket from the motorcycle, be careful not to drop any parts or the bracket onto the fuel tank and other components, and not to scratch the fuel tank or other components with the crate bracket.

- Remove the four bolts (D = 8, L = 20) to remove the left and right handlebars and discard bolts.
- And then remove the lower bolts (D = 8, L = 18) on the bracket and discard them.
- Remove the upper bolts (D = 8, L = 16) to take off the crate bracket and foam pad and discard them.

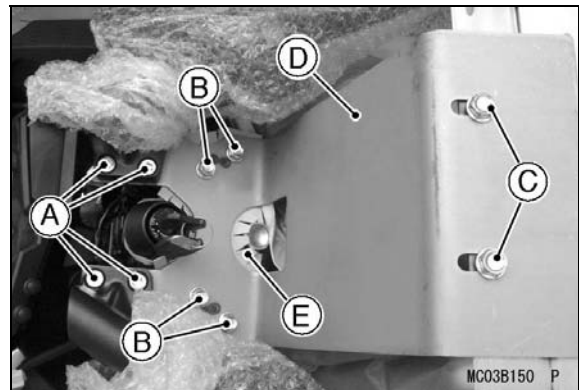

- A. Bolts (D = 8, L = 20)
- B. Lower Bolts (D = 8, L = 18)
- C. Upper Bolts (D = 8, L = 16)
- D. Crate Bracket
- E. Foam Pad

- Take out all the bolts and screws and remove the top and sides of the crate.
- Lift the vehicle upward to remove the under support. Lower the vehicle and roll the vehicle off the crate.

Opening Crate for Pattern B

⚠ WARNING

Crates have sharp edges and may have nails or screws that can cause cuts and injury. Always wear protective gloves, boots and eye protection when uncrating to prevent injury.

4 UNCRATING

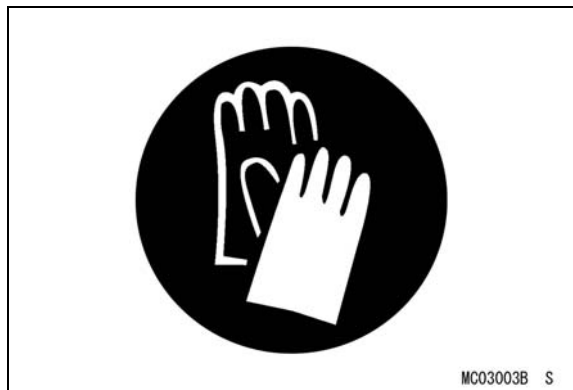

⚠ WARNING

The steel crate panel plates and fasteners have sharp edges. Always wear protective gloves, boots and eye protection when uncrating to prevent injury.



- Clear a space about 6 m (20 ft) square to give yourself plenty of space to work.
- Place the crate upright on its base.
- Remove the cardboard cover.
- Remove the parts box.

NOTICE

When removing the crate bracket from the motorcycle, be careful not to drop any parts or the bracket onto the fuel tank and other components, and not to scratch the fuel tank or other components with the crate bracket.

- First, remove the lower bolt (D = 22, L = 10) (1) at the steering stem and discard it.
- Remove the upper bolts (D = 8, L = 12) (2) to take off the crate bracket and discard them.
- Remove the lower bolts (D = 6, L = 8) (2) to take off the front master cylinder and discard the bolts.
- Remove the upper bolt (D = 8, L = 12) (1) to take off the crate bracket and discard them.

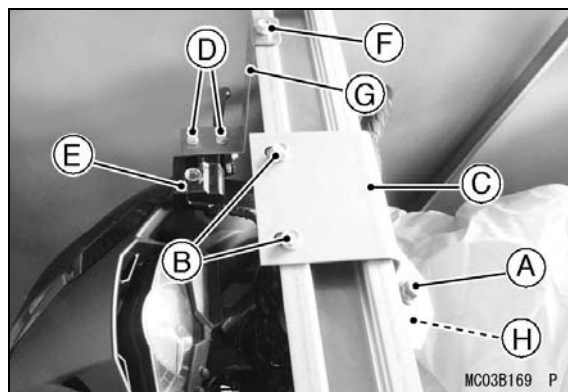

- A. Lower Bolt (D = 22, L = 10)
- B. Upper Bolts (D = 8, L = 12)
- C. Crate Bracket
- D. Lower Bolts (D = 6, L = 8)
- E. Front Master Cylinder
- F. Upper Bolt (D = 8, L = 12)
- G. Crate Bracket
- H. Dummy Bolt

- Take out all the bolts and screws and remove the top and sides of the crate.

NOTE

- Remove the dummy bolt after rolling the vehicle off the crate base.
- Remove the lower support bracket bolts (D = 8, L = 12) (2) on the left and right sides and discard them.
- Lift the vehicle upward about 10 cm (4 in.) and remove the lower support brackets and rubber washers (D = 50 × 3) (4) on the left and right sides.
- Roll the vehicle off the crate base.

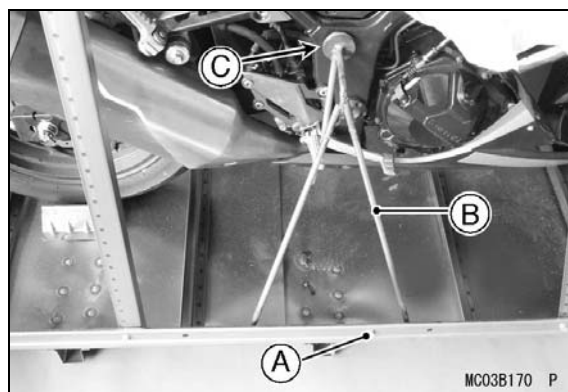

- A. Bolt (D = 8, L = 12)
- B. Lower Support Bracket
- C. Rubber Washer (D = 50 × 3)

Parts Check for Pattern A

- Open the parts box, and check the parts against the illustrations. There may be minor differences between these illustrations and the actual vehicle parts. In the following charts under Remarks, D = diameter in millimeters, and L = length in millimeters.

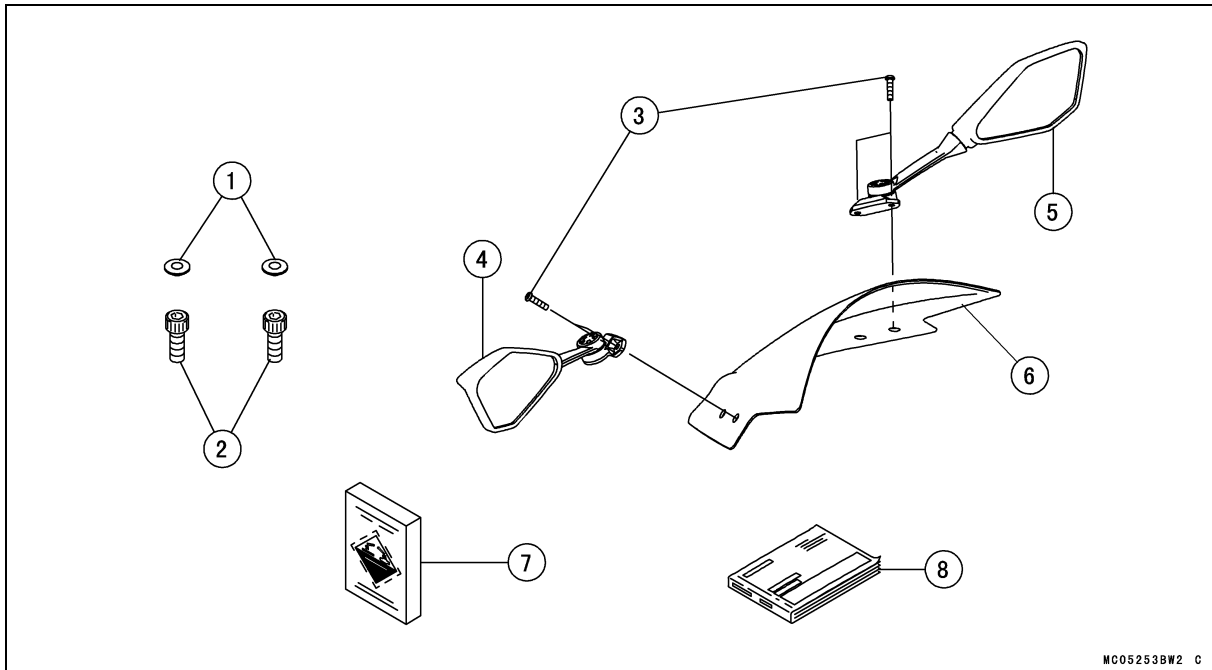

No.	Part Name	Qty	Remarks
1	Plug, Socket Bolt, Handlebar	4	D = 14.5
2	Socket Bolt, Handlebar	4	D = 8, L = 22
3	Socket Bolt, Rear View Mirror and Windshield	4	D = 6, L = 25
4	Left Rear View Mirror	1	
5	Right Rear View Mirror	1	
6	Windshield	1	
7	Battery Electrolyte, FTX9-BS	1	
8	Owner's Manual	1	

6 UNCRATING

Parts Check for Pattern B

- Open the parts box, and check the parts against the illustrations. There may be minor differences between these illustrations and the actual vehicle parts. In the following charts under Remarks, D = diameter in millimeters, and L = length in millimeters.

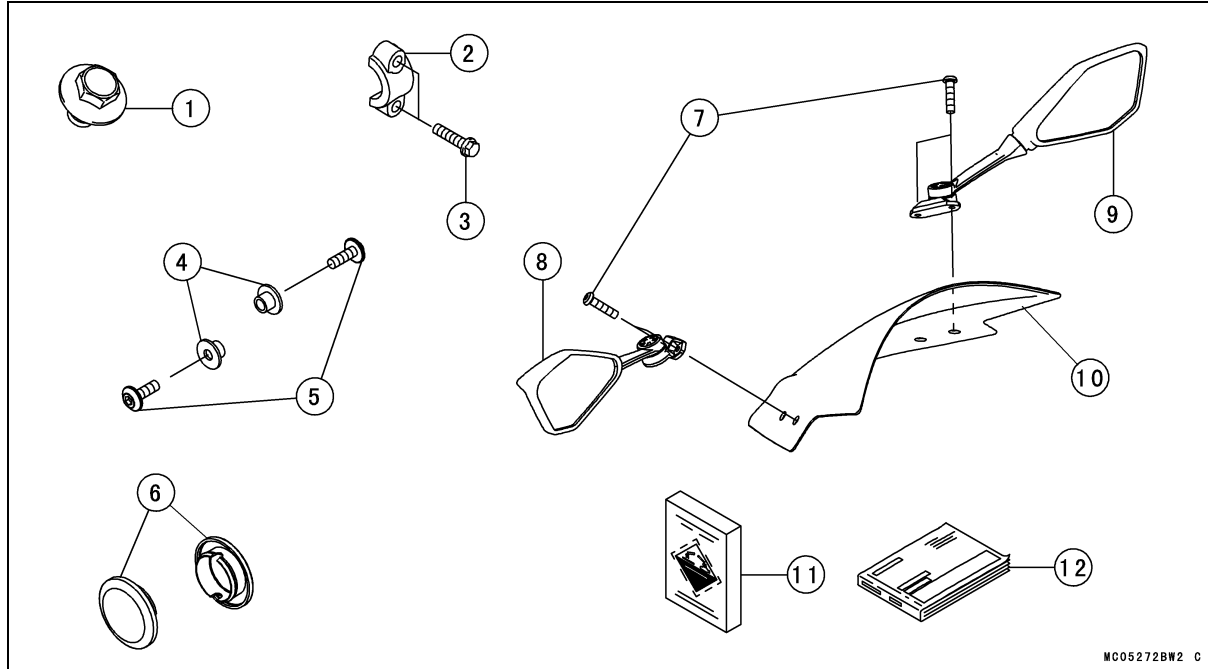

No.	Part Name	Qty	Remarks
1	Steering Stem Head Bolt	1	D = 16, L = 22
2	Clamp, Front Master Cylinder	1	
3	Flanged Bolt, Clamp, Front Master Cylinder	2	D = 5, L = 22
4	Collar, Front Seat	2	D = 6.8
5	Socket Bolt, Front Seat	2	D = 6, L = 18
6	Cap, Frame	2	
7	Socket Bolt, Rear View Mirror and Windshield	4	D = 6, L = 25
8	Left Rear View Mirror	1	
9	Right Rear View Mirror	1	
10	Windshield	1	
11	Battery Electrolyte, FTX9-BS	1	
12	Owner's Manual	1	

This page intentionally left blank.

8 UNCRATING

Parts Check for Pattern C

- Open the parts box, and check the parts against the illustrations. There may be minor differences between these illustrations and the actual vehicle parts. In the following charts under Remarks, D = diameter in millimeters, and L = length in millimeters.

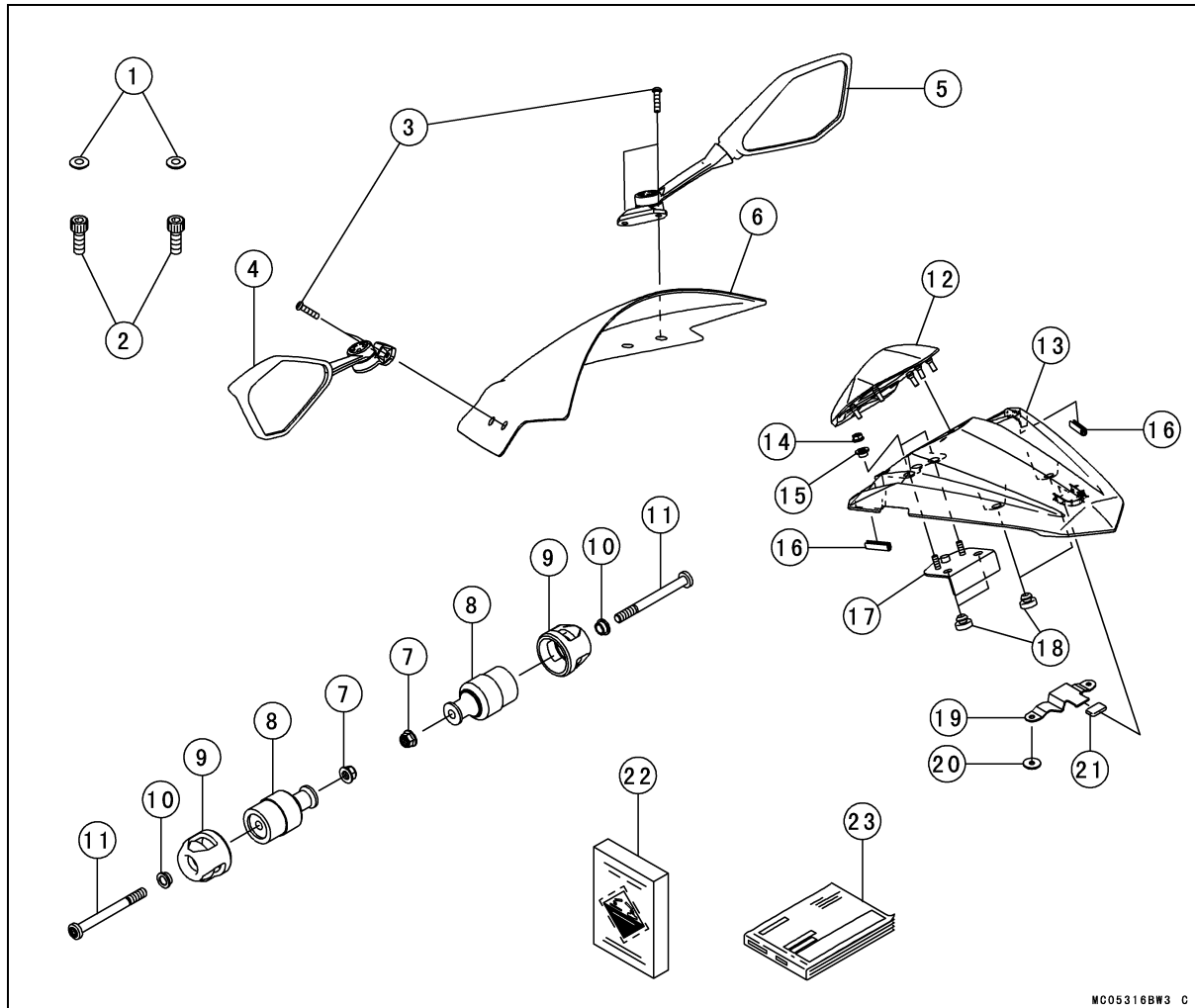

MC05316BW3 C

No.	Part Name	Qty	Remarks
1	Plug, Socket Bolt, Handlebar	4	D = 14.5
2	Socket Bolt, Handlebar	4	D = 8, L = 22
3	Socket Bolt, Rear View Mirror and Windshield	4	D = 6, L = 25
4	Left Rear View Mirror	1	
5	Right Rear View Mirror	1	
6	Windshield	1	
7	Locknut, Guard Assy	2	D = 10
8	Boss, Guard Assy	2	
9	Pad, Guard Assy	2	
10	Collar, Guard Assy	2	D = 10.2, L = 7
11	Bolt, Guard Assy	2	D = 10, L = 105
12	Damper, Single Seat Cover	1	
13	Seat Cover, Single Seat Cover	1	
14	Nut, Single Seat Cover	2	D = 6
15	Collar, Single Seat Cover	2	D = 10, L = 6.6
16	Trim, Single Seat Cover	2	L = 30
17	Bracket, Single Seat Cover	1	
18	Damper, Single Seat Cover	4	
19	Bracket	1	
20	Washer	2	6 × 20 × 1.6
21	Damper	1	
22	Battery Electrolyte, FTX9-BS	1	
23	Owner's Manual	1	

Assembly

Steering Stem Head Bolt for Pattern B

- Install the steering stem head bolt (D = 16, L = 22) and tighten the bolt to the specified torque.

Torque : 44 N·m (4.5 kgf·m, 32 ft·lb)

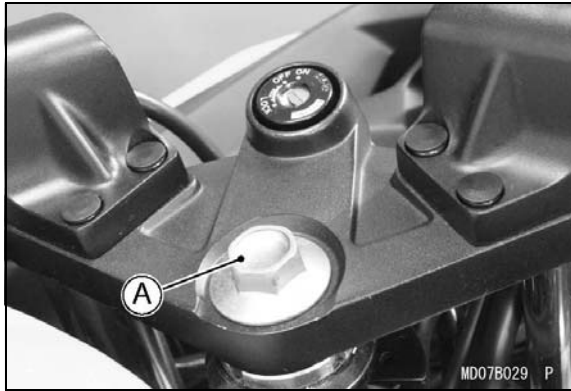

A. Steering Stem Head Bolt (D = 16, L = 22)

Handlebar for Pattern A and C

- Install the right handlebar with the mounting bolts (D = 8, L = 22) in place.
- Install the left handlebar in the same manner as the right handlebar.
- Tighten the right and left handlebar mounting bolts to the specified torque.

Torque: 25 N·m (2.5 kgf·m, 18 ft·lb)

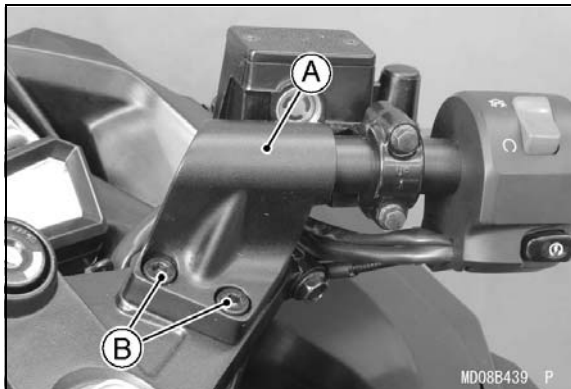

A. Right Handlebar

B. Mounting Bolts (D = 8, L = 22)

- Install the plugs (D = 14.5) on each mounting bolt top securely.

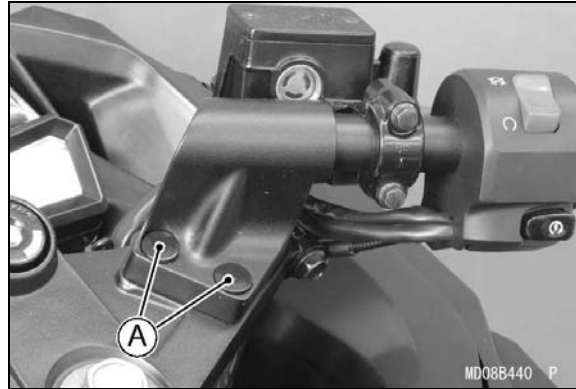

A. Plugs (D = 14.5)

Cables, Harness and Hoses Routing

- Check that the cables, wiring leads and hoses are routed correctly.

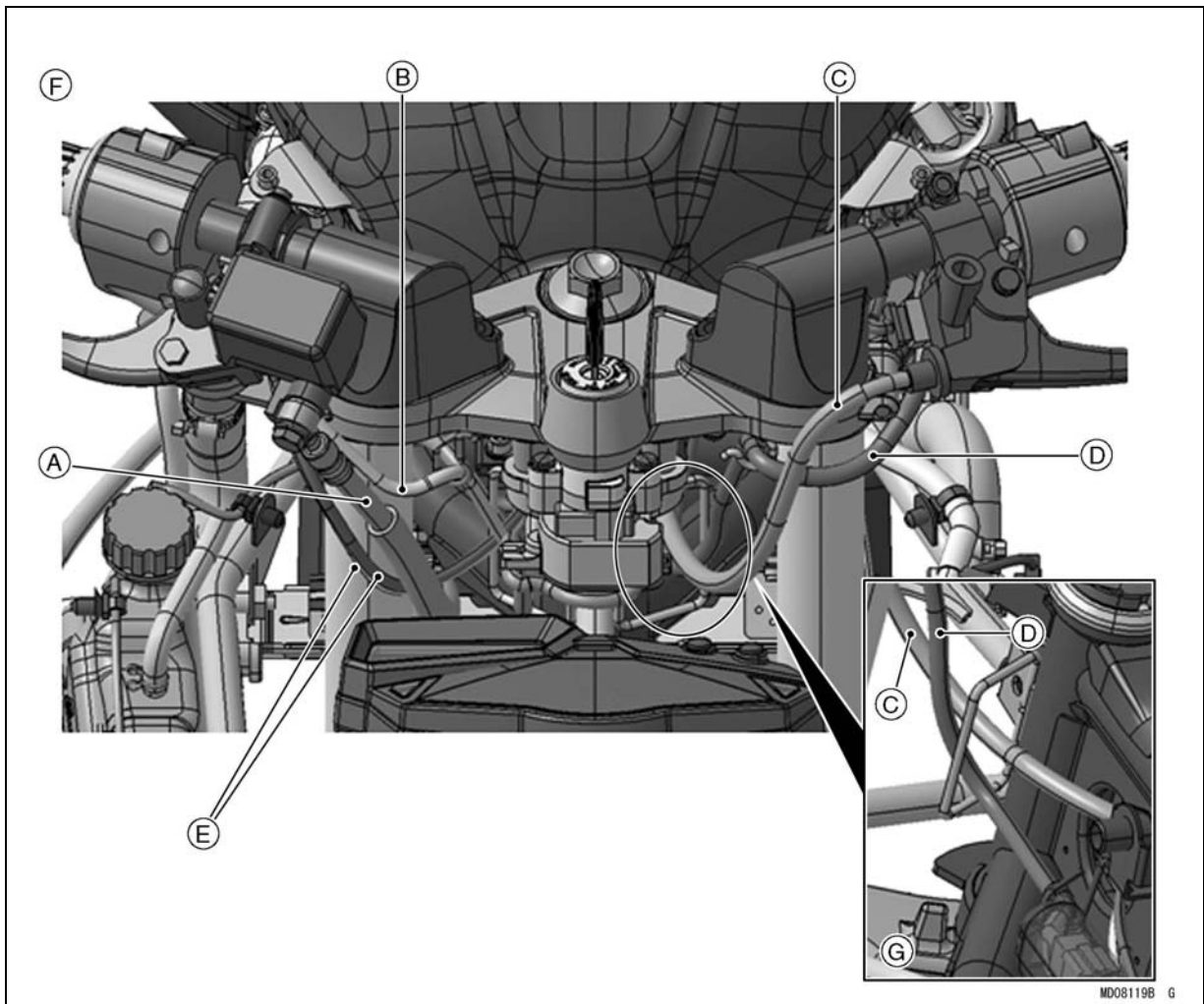

- A. Front Brake Hose
- B. Right Switch Housing Harness
- C. Clutch Cable
- D. Left Switch Housing Harness

- E. Throttle Cables
- F. Viewed Front
- G. Viewed Left Side

MD081198 G

Front Brake Master Cylinder for Pattern B

- Connect the front brake light switch connectors to the switch terminals of the front brake master cylinder.

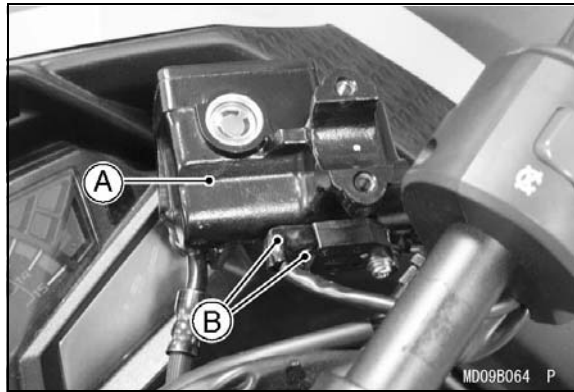

- A. Front Brake Master Cylinder**
- B. Front Brake Light Switch Connectors**

- Install the front master cylinder with its clamp and bolts (D = 6, L = 18) so that the arrow mark on the clamp faces upward.
- Position the master cylinder so that the mating surface of the front and rear master cylinder clamps aligns with the punched mark on the handlebar.

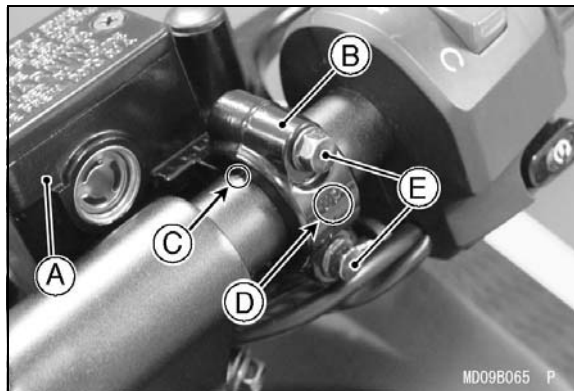

- A. Master Cylinder**
- B. Clamp**
- C. Punched Mark**
- D. Arrow Mark**
- E. Front Master Cylinder Clamp Bolts (D = 6, L = 18)**

- Tighten the upper clamp bolt first and then the lower clamp bolt to the specified torque.

Torque: 8.8 N·m (0.90 kgf·m, 78 in·lb)

Clutch Cable

- Apply a light coat of grease on the clutch inner cable.
- Line up the slots on the clutch lever, locknut, and adjuster.
- Fit the tip of the clutch inner cable into the lever socket, slide the inner cable through the slots, and release the outer cable into the adjuster.

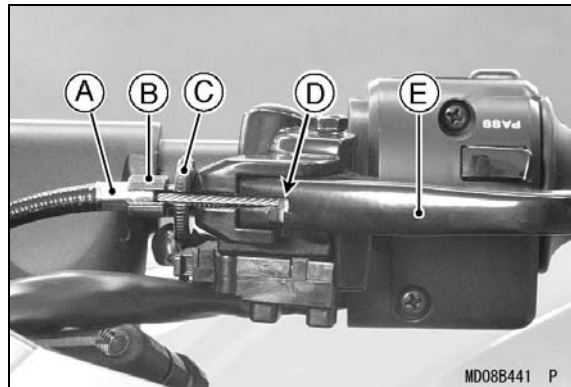

- A. Clutch Cable**
- B. Adjuster**
- C. Locknut**
- D. Cable Tip**
- E. Clutch Lever**

Windshield and Rear View Mirrors (Left and Right)

- Fit the windshield onto the upper fairing, and install each rear view mirror with the two socket bolts (D = 6, L = 25).
- Install other mirror with the two socket bolts (D = 6, L = 25).
- Tighten all socket bolts (D = 6, L = 25) securely. Be careful not to overtighten them.

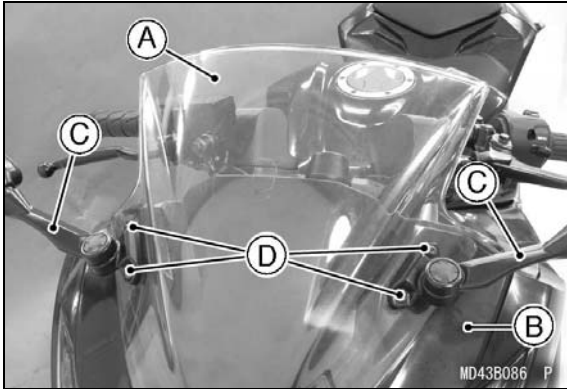

- A. Windshield
- B. Upper Fairing
- C. Left and Right Rear View Mirrors
- D. Socket Bolts (D = 6, L = 25)

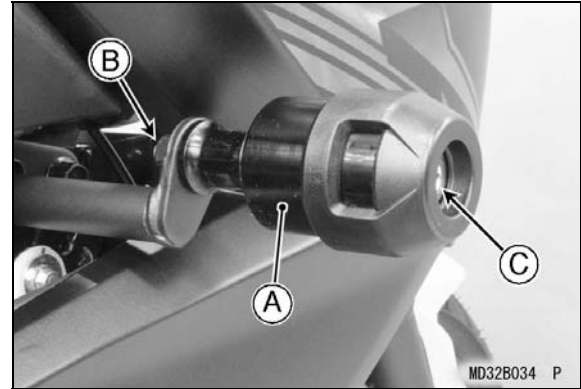

- A. Guard Assy
- B. Nut (D = 10)
- C. Bolt (D = 10, L = 105)

Cap for Pattern B

- Install the caps on the left and right side of the frame.

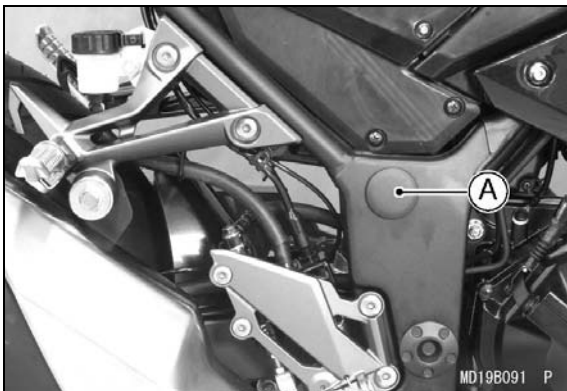

- A. Cap

Guard (Left and Right) for Pattern C

- Install the guard assy parts and tighten the bolt (D = 10, L = 105) and nut (D = 10).

Single Seat Cover for Pattern C

- Remove the bolts.

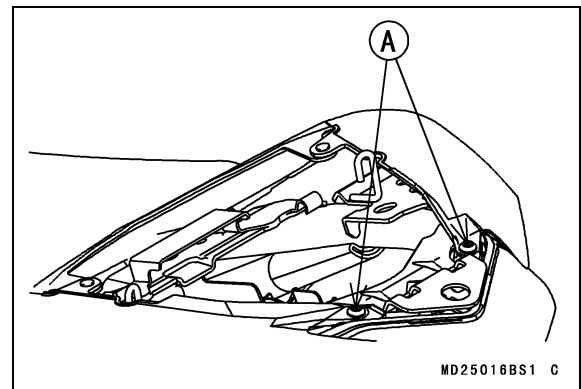

- A. Bolts

- Fit the damper to the bracket.
- Install the bracket and washers with previously removed bolts.

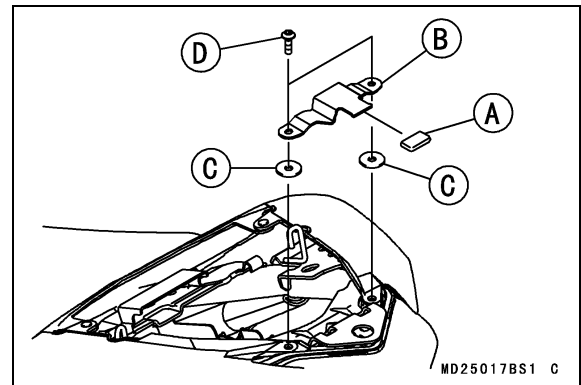

- A. Damper
- B. Bracket
- C. Washers
- D. Bolts

14 PREPARATION

- Insert the damper into the slit on the seat cover.
- Push down the front part of the seat cover until lock clicks.
- Pull up the front end of the seat cover to make sure it is securely locked.

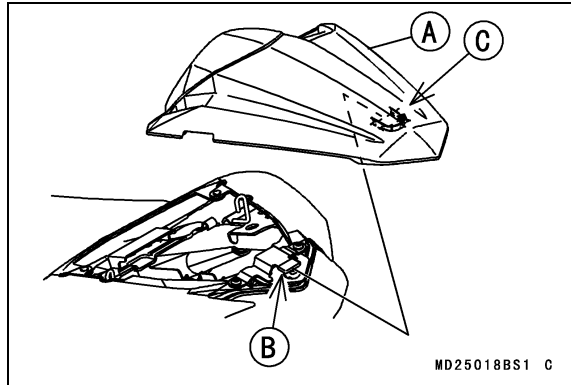

- A. Seat Cover
- B. Damper
- C. Slit

Brake Disc Cleaning

- Clean the front and rear brake discs using oilless solvent.

⚠ WARNING

An anticorrosive treatment applied to the brake discs will increase braking distance and can cause an accident resulting in serious injury or death. Remove the anticorrosive treatment using an oilless solvent.

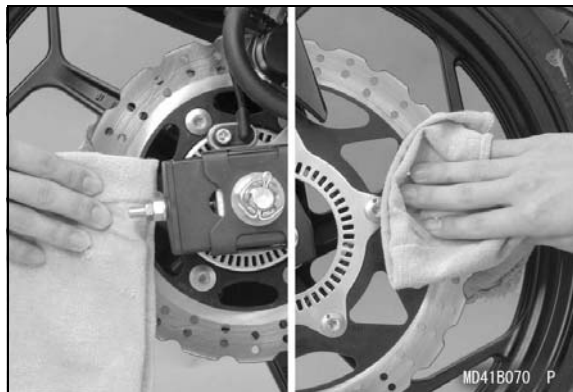

Preparation

Battery Service

Battery Removal

The battery used in this motorcycle is a sealed type and never needs to be refilled. Follow the

procedure for activating a new battery to ensure the best possible battery performance.

- Remove the bolt (D = 5, L = 16) and collar (D = 5.8) on the left and right side covers.
- Pull the left and right side covers to the outside for detaching the projections.

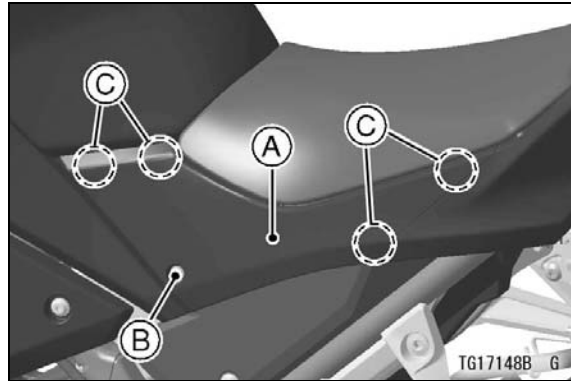

- A. Side Cover
- B. Bolt (D = 5, L = 16) and Collar (D = 5.8)
- C. Projections

- For Pattern A and C, remove the bolts (D = 6, L = 18) and collars (D = 6.8) on the front seat.
- Pull off the front seat to the up and rear.

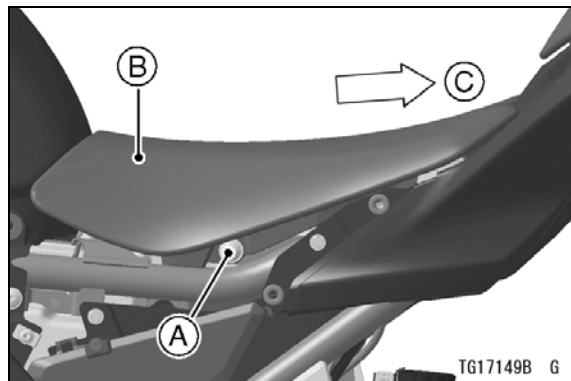

- A. Bolt (D = 6, L = 18) and Collar (D = 6.8) for Pattern A and C
- B. Front Seat
- C. Pull Up and Rear

- Remove the battery cover screw (D = 5, L = 16) and pull up the battery cover with the relay box.

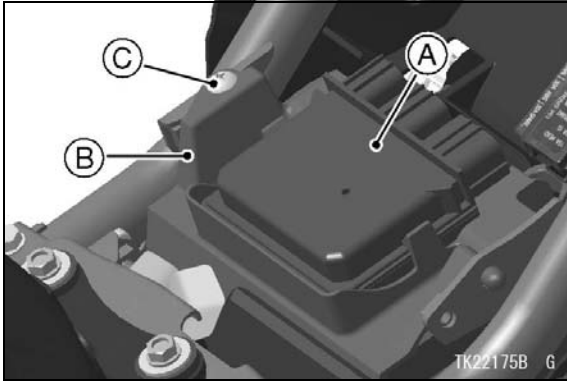

- A. Relay Box
- B. Battery Cover
- C. Battery Cover Screw (D = 5, L = 16)

- Take the battery out of the rear fender.

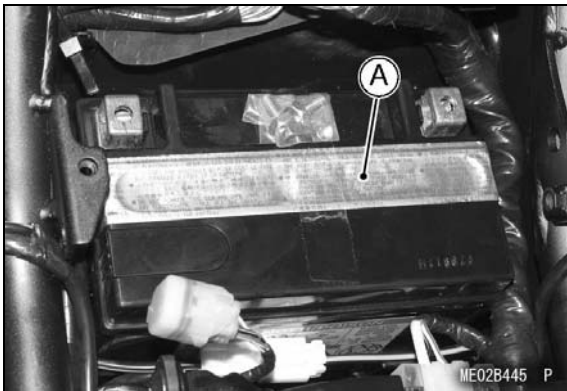

A. Battery

- Clean the terminals.

Battery Activation

Electrolyte Filling

- Make sure that the model name of the electrolyte container matches the model name of the battery. These names must be the same.

Battery Model Name

EX300A/B: FTX9-BS

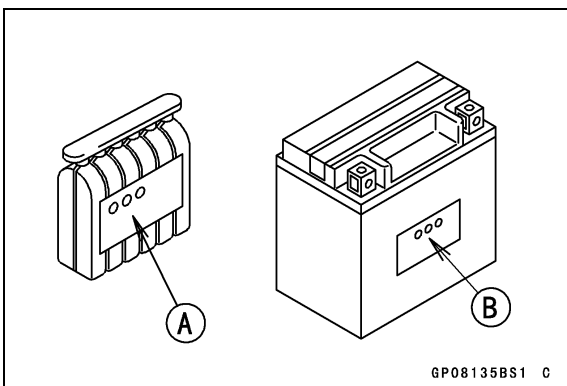

- A. Model Name of the Electrolyte
- B. Model Name of the Battery

NOTICE

Each battery comes with its own specific electrolyte container; using the wrong container may overflow the battery with incorrect electrolyte, which can shorten battery life and deteriorate battery performance. Be sure to use the electrolyte container with the same model name as the battery since the electrolyte volume and specific gravity vary with the battery type.

NOTICE

Do not remove the aluminum sealing sheet from the filler ports until just prior to use. Be sure to use the dedicated electrolyte container for correct electrolyte volume.

⚠ DANGER

Sulfuric acid in battery electrolyte can cause severe burns. To prevent burns, wear protective clothing and safety glasses when handling electrolyte. If the electrolyte comes in contact with your skin or eyes, wash the area with liberal amounts of water and seek medical attention for more severe burns.

- Place the battery on a level surface.
- Check to see that the sealing sheet has no peeling, tears, or holes in it.
- Remove the sealing sheet.

NOTE

- *The battery is vacuum sealed. If the sealing sheet has leaked air into the battery, it may require a longer initial charge.*

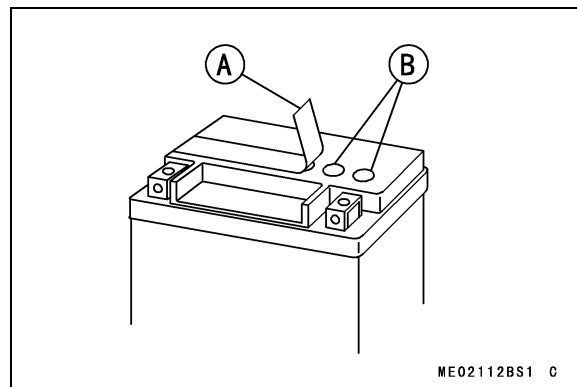

- A. Sealing Sheet
- B. Filler Ports

16 PREPARATION

- Remove the electrolyte container from the vinyl bag.
- Detach the strip of caps from the container and set aside, these will be used later to seal the battery.

NOTE

- Do not pierce or otherwise open the sealed cells of the electrolyte container. Do not attempt to separate individual cells.

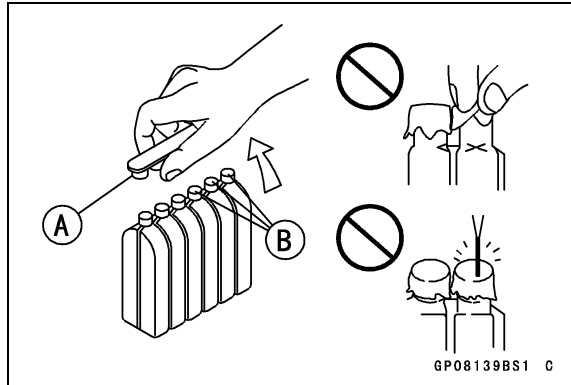

- A. Strip of Caps**
- B. Sealed Cells**

- Place the electrolyte container upside down with the six sealed cells into the filler ports of the battery. Hold the container level, push down to break the seals of all six cells. You will see air bubbles rising into each cell as the ports fill.

NOTE

- Do not tilt the electrolyte container.

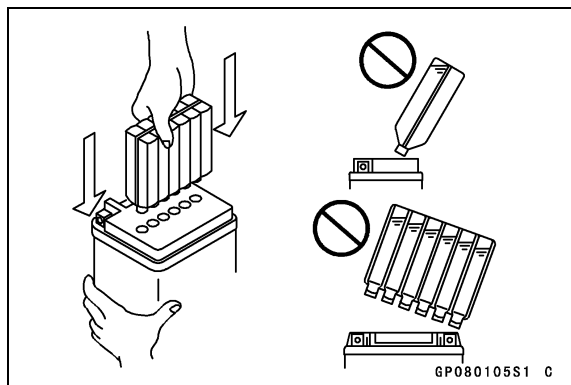

- Check the electrolyte flow.
- If no air bubbles are coming up from the filler ports, or if the container cells have not emptied completely, tap the container a few times.

NOTE

- Be careful not to have the battery fall down.

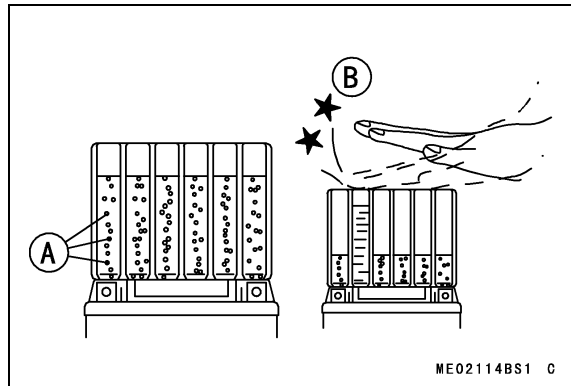

- A. Air Bubbles**
- B. Tap the Container**

- Keep the container in place. Don't remove the container from the battery, the battery requires all the electrolyte from the container for proper operation.

NOTICE

Removal of the container before it is completely empty can shorten the service life of the battery. Do not remove the container until it is completely empty.

- After filling, let the battery sit for 20 ~ 60 minutes with the electrolyte container kept in place, which is required for the electrolyte to fully permeate into the plates.
- Make sure that the container cells have emptied completely, and remove the container from the battery.
- Place the strip of caps loosely over the filler ports, press down firmly with both hands to seat the strip of caps into the battery (don't pound or hammer). When properly installed, the strip of caps will be level with the top of the battery.

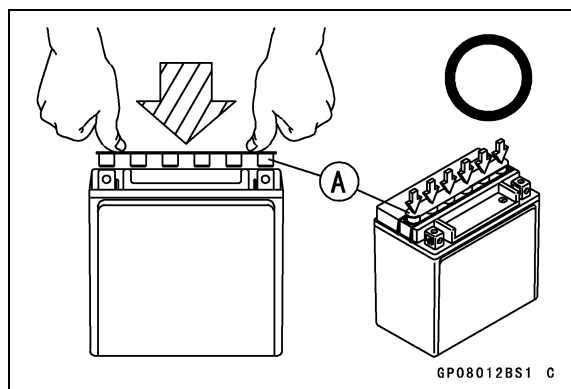

- A. Strip of Caps**

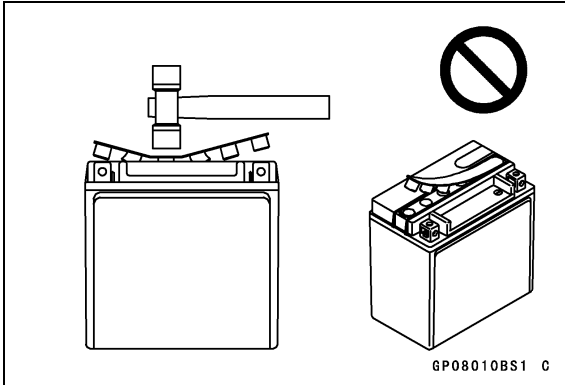

NOTICE

Once the strip of caps is installed onto the battery, never remove the caps, nor add water or electrolyte to the battery.

NOTE

○Charging the battery immediately after filling can shorten service life.

Initial Charge

● Newly activated sealed batteries require an initial charge.

Standard Charge: 0.9 A × 5 ~ 10 hours

● If using a recommended battery charger, follow the charger's instructions for newly activated sealed battery.

Kawasaki-recommended chargers:

Battery Mate 150-9

OptiMate PRO 4-S/PRO S/PRO 2

Yuasa MB-2040/2060

Christie C10122S

- If the above chargers are not available, use equivalent one.
- Let battery sit 30 minutes after initial charge, then check voltage using a voltmeter. (Voltage immediately after charging becomes temporarily high. For accurate measuring, let the battery sit for given time.)

NOTE

○Charging rates will vary depending on how long the battery has been stored, temperature, and the type of charger used. If voltage is not at least 12.6 volts, repeat charging cycle.

○To ensure maximum battery life and customer satisfaction, it is recommended the battery be load tested at three times its amp-hour rating for 15 seconds.

Re-check voltage and if less than 12.6 volts repeat the charging cycle and load test. If still below 12.6 volts the battery is defective.

Battery Installation

- Turn the ignition switch off.
- Run the red capped (positive) cable (+) correctly.

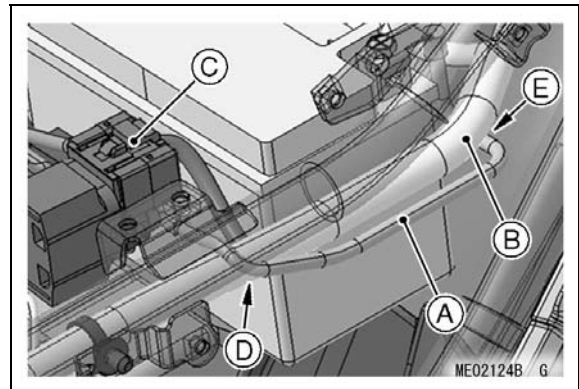

A. Red Capped (Positive) Cable (+)

B. Main Harness

C. Main Fuse

D. Run the red capped (positive) cable (+) above the main harness at the main fuse side.

E. Run the red capped (positive) cable (+) under the main harness at the terminal side.

- Place the battery into the rear fender.
- Connect the red capped cable to the (+) terminal, and then connect the black cable to the (-) terminal.
- Put a light coat of grease on the terminals to prevent corrosion.
- Cover the (+) terminal with its protective cap.
- Insert the tab of the battery cover into the hole of the frame.

18 PREPARATION

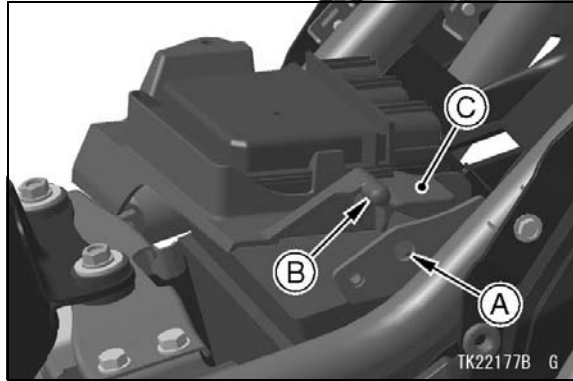

- A. Hole**
- B. Tab**
- C. Battery Cover**

- Install the battery cover screw (D = 5, L = 16) and tighten it securely.
- Insert the tabs on the rear of the front seat into the slots on the frame.

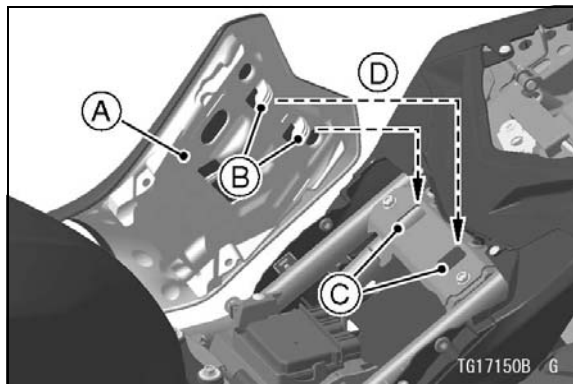

- A. Front Seat**
- B. Tabs**
- C. Slots**
- D. Insert**

- Install the collars (D = 6.8) and front seat bolts (D = 6, L = 18).
- Tighten the front seat bolts securely.
- Insert the projections of the left side cover into the grommets.

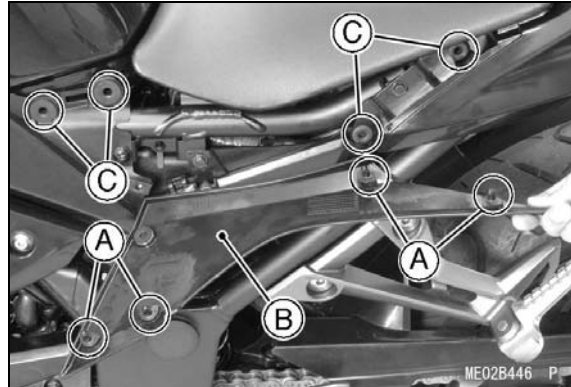

- A. Projections**
- B. Left Side Cover**
- C. Grommets**

- Install the collar (D = 5.8) and side cover bolt (D = 5, L = 16).
- Tighten the side cover bolt securely.
- Install the right side cover in the same manner as the left side cover.

Front Brake

Front Brake Fluid Level Inspection

- With the front brake fluid reservoir held horizontal, check that the fluid level is above the lower level line.

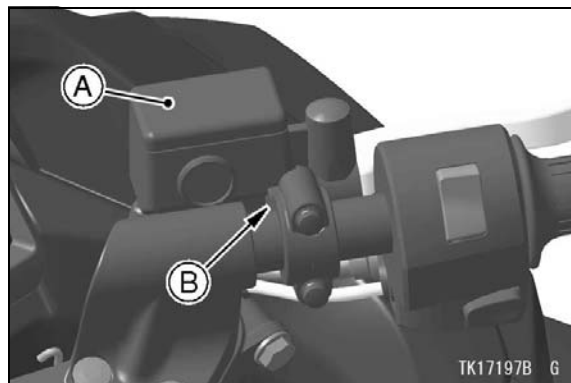

- A. Front Brake Fluid Reservoir**
- B. Lower Level Line**

- If the fluid level in the reservoir is lower than the lower level line, check for fluid leaks in the front brake lines and fill the reservoir.
- Loosen the screws to remove the front brake fluid reservoir cap and diaphragm.
- Fill the reservoir to the upper level line with DOT3 or DOT4 brake fluid. Inside the front brake reservoir is a stepped line showing the upper level line.

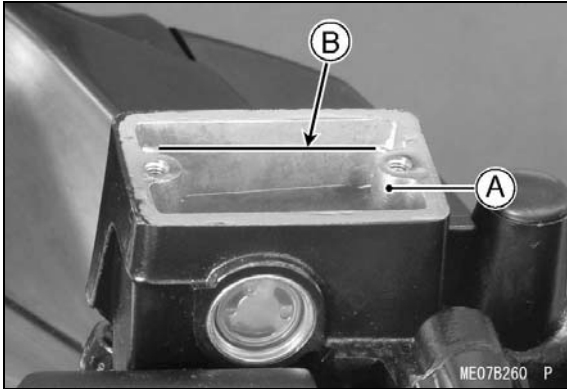

A. Front Brake Fluid Reservoir
B. Upper Level Line

⚠ WARNING

When working with the disc brake, observe the precautions listed below.

- Never reuse old brake fluid.
- Do not use fluid from a container that has been left unsealed or that has been open for a long time.
- Do not mix two types and brands of fluid for use in the brake. This lowers the brake fluid boiling point and could cause the brake to be ineffective. It may also cause the rubber brake parts to deteriorate.
- Do not leave the reservoir cap off for any length of time to avoid moisture contamination of the fluid.
- Do not change the fluid in the rain or when a strong wind is blowing.
- Brake fluid quickly damages painted surfaces; any spilled fluid should be completely wiped up immediately.
- If any of the brake line fittings or the bleed valve is opened at any time, the **AIR MUST BE BLED FROM THE BRAKE LINE.**

- Operate the brake lever several times.
- If it feels spongy, there might be air in the brake line.
- If necessary, bleed the air in the front brake lines.
- Also check for fluid leakage around the fittings.

Brake Line Air Bleeding

- Loosen the screws to remove the reservoir cap and diaphragm, and check that there is plenty of fluid in the reservoir.

NOTE

○ The fluid level must be checked several times, during the bleeding operation and replenished as necessary. If the fluid in the reservoir runs completely out any time during bleeding, the bleeding operation must be repeated from the beginning since air will have entered the line.

- Attach a clear plastic hose to the bleed valve on the front brake caliper and run the other end of the hose into a container.
- With the reservoir cap off, slowly pump the brake lever several times until no air bubbles can be seen rising up through the fluid from the holes at the bottom of the reservoir. This bleeds the air from the brake master cylinder end of the line.
- Pump the brake lever a few times until it becomes hard and then, holding the lever squeezed, quickly open (turn counterclockwise) and close the bleed valve. Then release the lever. Repeat this operation until no more air can be seen coming out into the plastic hose.

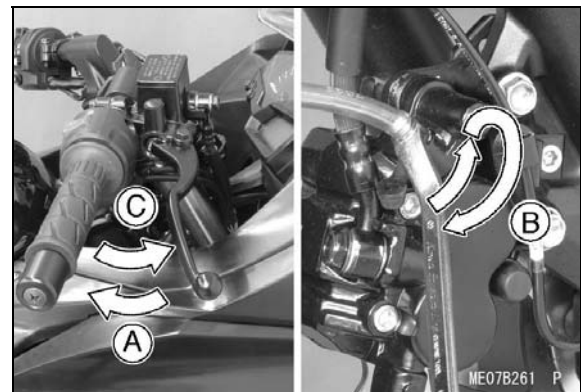

A. Hold the brake lever applied.
B. Quickly open and close the bleed valve.
C. Release the brake lever.

- When air bleeding is finished, check that the fluid level is between the upper and lower level lines.
- Install the diaphragm and reservoir cap.
- Tighten the bleed valve to the specified torque.

Torque: 5.5 N·m (0.56 kgf·m, 49 in·lb)

- Apply the brake forcefully for a few seconds, and check for fluid leakage around the fittings.

Rear Brake

Rear Brake Fluid Level Inspection

- With the rear brake fluid reservoir held horizontal, check that the fluid level is between the upper and lower level lines.

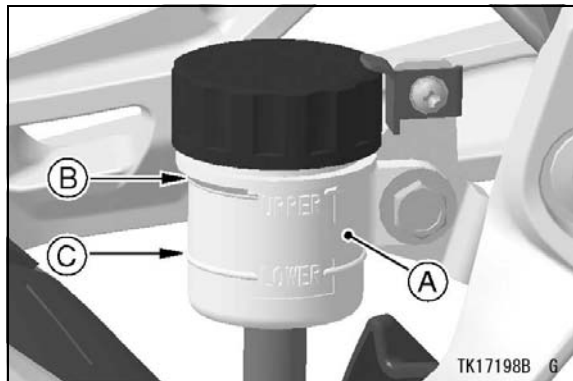

- A. Rear Brake Fluid Reservoir**
- B. Upper Level Line**
- C. Lower Level Line**

- If the fluid level in the reservoir is lower than the lower level line, check for fluid leaks in the brake line, and fill the reservoir.
- Loosen the reservoir cap stopper screw to remove the reservoir cap and diaphragm, and fill the reservoir to the upper level line with DOT4 brake fluid, and reinstall diaphragm and reservoir cap.

NOTE

- First, tighten the rear brake fluid reservoir cap clockwise by hand until slight resistance is felt indicating that the cap is seated on the reservoir body, then tighten the cap an additional 1/6 turn while holding the brake fluid reservoir body.

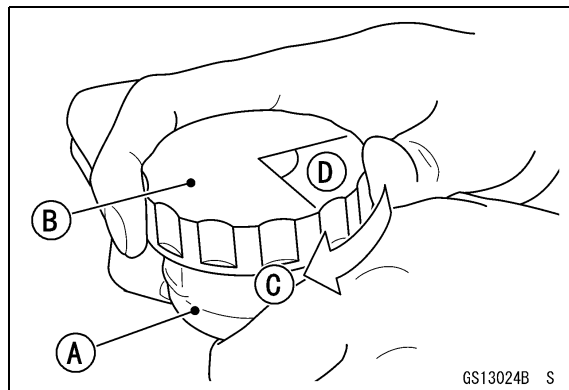

- A. Reservoir**
- B. Reservoir Cap**
- C. Clockwise**
- D. 1/6 turn**

- Operate the brake pedal several times.
- If it feels spongy, there might be air in the brake line.
- If necessary, bleed the air in the rear brake line.
- Also check for fluid leakage around the fittings.

Brake Line Air Bleeding

- Loosen the reservoir cap stopper screw to remove the reservoir cap and diaphragm, and check that there is plenty of fluid in the reservoir.

NOTE

- The fluid level must be checked several times, during the bleeding operation and replenished as necessary. If the fluid in the reservoir runs completely out any time during bleeding, the bleeding operation must be repeated from the beginning since air will have entered the line.
- Attach a clear plastic hose to the bleed valve on the rear brake caliper and run the other end of the hose into a container.
- With the reservoir cap off, slowly pump the brake pedal several times until no air bubbles can be seen rising up through the fluid from the holes at the bottom of the reservoir. This bleeds the air from the rear brake master cylinder end of the line.
- Pump the brake pedal a few times until it becomes hard and then, holding the pedal pushed down, quickly open (turn counter-clockwise) and close the bleed valve. Then release the pedal. Repeat this operation until no more air can be seen coming up into the plastic hose.

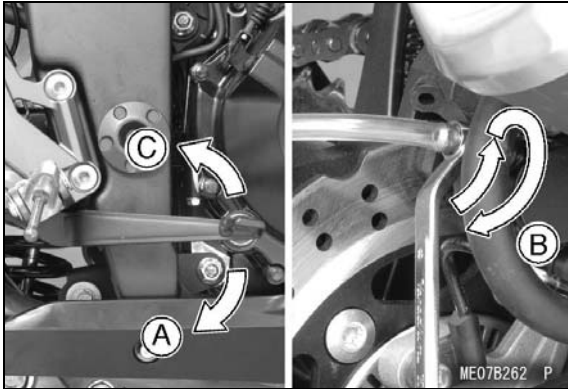

- A. Hold the brake pedal applied.**
- B. Quickly open and close the bleed valve.**
- C. Release the brake pedal.**

- When air bleeding is finished, check that the fluid level is between the upper and lower level lines.
- Tighten the bleed valve to the specified torque.

Torque: 5.5 N·m (0.56 kgf·m, 49 in·lb)

- Install the diaphragm and reservoir cap.

NOTE

○ *First, tighten the rear brake fluid reservoir cap clockwise by hand until slight resistance is felt indicating that the cap is seated on the reservoir body, then tighten the cap an additional 1/6 turn while holding the brake fluid reservoir body.*

- Tighten the reservoir cap stopper screw.
- Apply the brake forcefully for a few seconds, and check for fluid leakage around the fittings.

Clutch Lever and Cable

Clutch Lever Free Play Inspection

- Check that the clutch lever has the specified amount of free play.

Clutch Lever Free Play:

2 ~ 3 mm (0.08 ~ 0.12 in.)

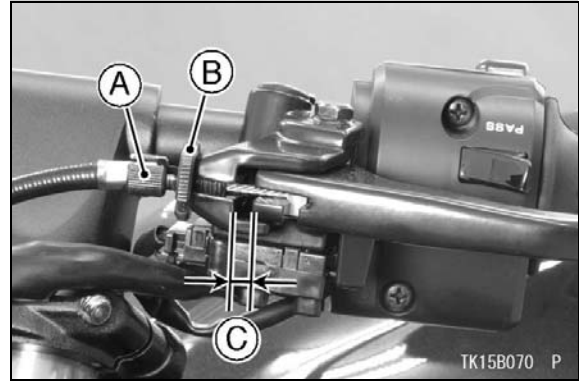

- A. Adjuster**
- B. Locknut**
- C. 2 ~ 3 mm (0.08 ~ 0.12 in.)**

- If the free play is incorrect, adjust the free play.

Clutch Lever Free Play Adjustment

- Turn the adjuster so that the clutch lever will have 2 ~ 3 mm (0.08 ~ 0.12 in.) of free play.
- If it cannot be done, use the adjusting nuts on the lower end of the clutch cable.
- Slide the dust cover, and loosen the adjusting nuts on the lower end of the clutch cable.
- Adjust the free play.

⚠ WARNING

Operation with incorrectly routed or improperly adjusted cable could result in an unsafe riding condition. Be sure the cable is routed correctly and properly adjusted.

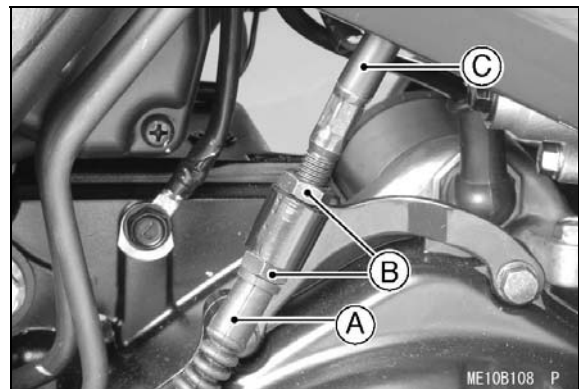

- A. Dust Cover**
- B. Adjusting Nuts**
- C. Clutch Cable**

- Tighten the adjusting nuts, and slide the dust cover back into place.

NOTE

- After the adjustment is made, start the engine and check that the clutch does not slip and that it releases properly.
- For minor corrections, use the adjuster at the clutch lever.

Drive Chain

Drive Chain Slack and Wheel Alignment Inspection

- Set the motorcycle up on its side stand.
- Make sure that the drive chain has the specified amount of play, and that the left and right notches are on the same marks or points on the left and right of the swingarm.

⚠ WARNING

Misalignment of the wheel will result in abnormal tire wear and can cause an unsafe riding condition. Be sure the wheel is properly aligned.

- Rotate the rear wheel to find the position where the chain is tightest, and measure the maximum chain slack by pulling up and pushing down the chain midway between the engine sprocket and rear wheel sprocket.

Drive Chain Slack:

20 ~ 30 mm (0.8 ~ 1.2 in.)

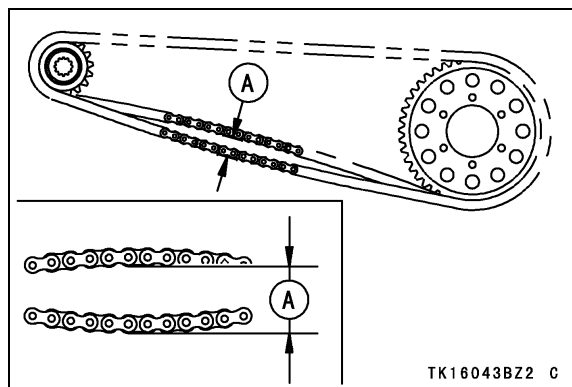

A. 20 ~ 30 mm (0.8 ~ 1.2 in.)

- If the drive chain is too tight or too loose, adjust it so that the chain slack will be within the standard value.

⚠ WARNING

A chain that breaks or jumps off the sprockets could snag on the engine sprocket or lock the rear wheel, severely damaging the motorcycle and causing it to go out of control. Inspect the chain for damage and proper adjustment.

Drive Chain Slack Adjustment

- Remove the cotter pin, and loosen the rear axle nut.
- Loosen the left and right chain adjuster locknuts.

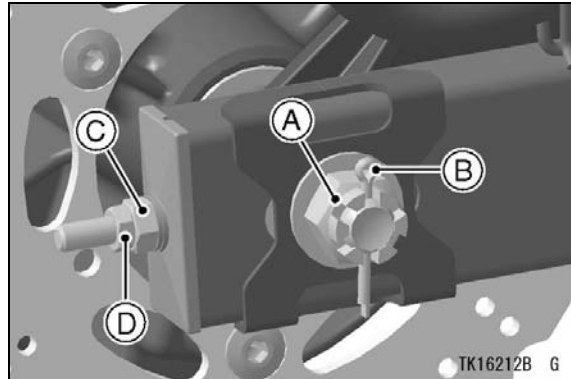

- A. Rear Axle Nut**
- B. Cotter Pin**
- C. Chain Adjuster**
- D. Chain Adjuster Locknut**

- If the chain is too loose, turn in the left and right chain adjusters evenly.
- If the chain is too tight, turn out the left and right chain adjusters evenly.
- Turn both chain adjusters evenly until the drive chain has the correct amount of slack. To keep the chain and wheel properly aligned, the notch on the left wheel alignment indicator should align with the same swingarm mark that the right indicator notch aligns with.

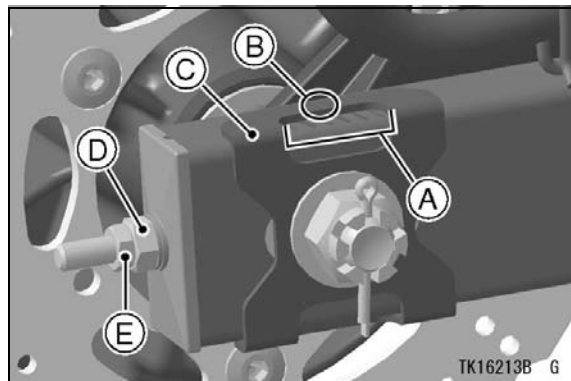

- A. Marks**
- B. Notch**
- C. Indicator**
- D. Chain Adjuster**
- E. Chain Adjuster Locknut**

NOTE

- Wheel alignment can also be checked using the straightedge or string method.

- Tighten both chain adjuster locknuts.
- Tighten the rear axle nut to the specified torque.

Torque: 98 N·m (10 kgf·m, 72 ft·lb)

- Rotate the wheel, measure the chain slack again at the tightest position, and readjust if necessary.
- Install a new cotter pin.

NOTE

- When inserting the cotter pin, if the slots in the nut do not align with the cotter pin hole in the axle, tighten the nut clockwise up to the next alignment.
- It should be within 30 degrees.
- Loosen once and tighten again when the slot goes past the nearest hole.

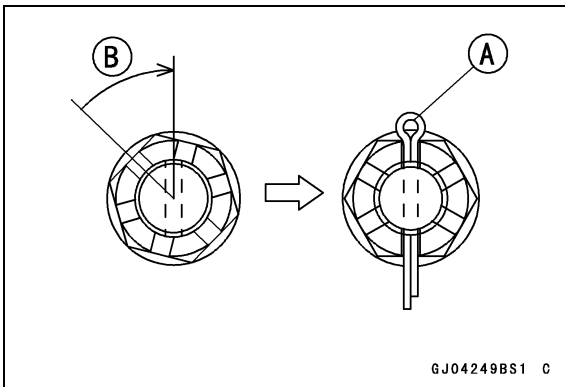

- A. Cotter Pin
- B. Turning Clockwise

- Bend the cotter pin over the nut.

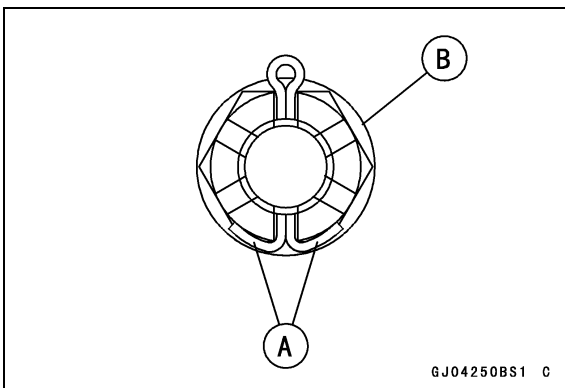

- A. Cotter Pin
- B. Nut

⚠ WARNING

A loose axle nut can lead to an accident resulting in serious injury or death. Tighten the axle nut to the proper torque and be sure the cotter pin is installed correctly.

- Check the rear brake effectiveness.

Rear Shock Absorber

Spring Preload Inspection

- Check the position of the spring preload adjuster on the rear shock absorber.

STD Spring Preload: No.2 position

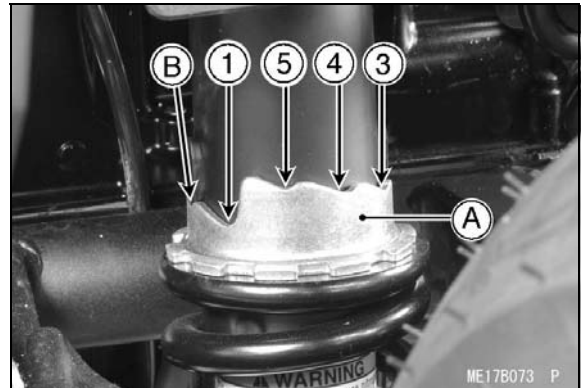

- A. Spring Preload Adjuster
- B. No.2 Position

- Turn the preload adjuster to the No.2 position.

Tire Air Pressures

- To prevent flat-spotting during shipment, the tires are over-inflated before crating. Adjust the pressures to the specified values in the front and rear, and make sure to tighten the caps securely.

Tire Air Pressure [when cold]:

- Front: 200 kPa (2.00 kgf/cm², 28 psi)
- Rear: 225 kPa (2.25 kgf/cm², 32 psi)



- A. Tire Air Pressure Gauge

Fuel

⚠ WARNING

Gasoline is extremely flammable and can be explosive under certain conditions, creating the potential for serious burns. When filling the tank, turn the ignition switch off. Do not smoke. Make sure the area is well ventilated and free from any source of flame or sparks; this includes any appliance with a pilot light.

- Open the fuel tank cap, and check for debris in the fuel tank.
- Fill the fuel tank with one gallon or four liters of unleaded gasoline. Use a gasoline with a minimum octane rating shown below.

For US, Canadian and Brazil Specifications

Fuel Type	Unleaded Gasoline
Minimum Octane Rating	Antiknock Index $\frac{(RON + MON)}{2}$ 87

For Other than US, Canadian and Brazil Specifications

Use clean, fresh unleaded gasoline with an octane rating equal to or higher than that shown in the table.

Fuel Type	Unleaded Gasoline
Minimum Octane Rating	Research Octane Number (RON) 91

- Close the fuel tank cap. Check for any leaks.

Coolant

Coolant Level Inspection

- Situate the motorcycle so that it is perpendicular to the ground.
- Check the coolant level through the coolant level gauge on the reserve tank located to the right of the front fork. The coolant level should be between the F (Full) and L (Low) level lines.

NOTE

○ Check the level when the engine is cold (room or atmospheric temperature).

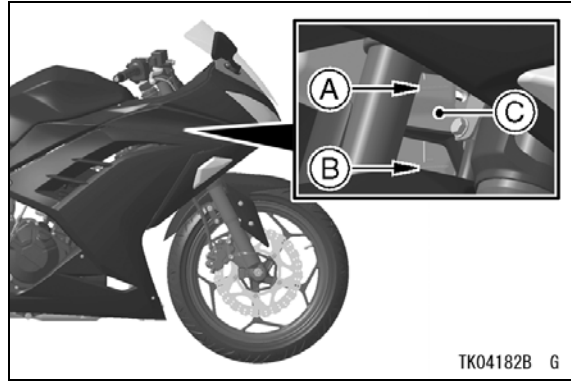

A. F (Full) Level Line

B. L (Low) Level Line

C. Reserve Tank

- If the amount of coolant is insufficient, add coolant into the reserve tank.

Coolant Filling

- Remove the cap from the reserve tank and add coolant through the filler opening to the F (Full) level line.

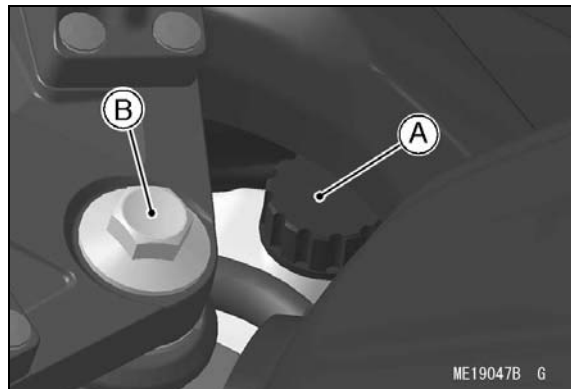

A. Reserve Tank Cap

B. Steering Stem Head Bolt

- Install the reserve tank cap.

NOTE

○ A permanent type of antifreeze is installed in the cooling system when shipped. It is colored green and contains ethylene glycol. It is mixed at 50% and has the freezing point of -35°C (-31°F).

Engine Oil (4-stroke)

Engine Oil Level Inspection

NOTE

○ This vehicle's engine is filled with 10W-40 oil from the factory. DO NOT DRAIN and refill the crankcase before use. Check oil level and drain plug tightness.

Engine Oil Drain Plug Torque:
30 N·m (3.1 kgf·m, 22 ft·lb)

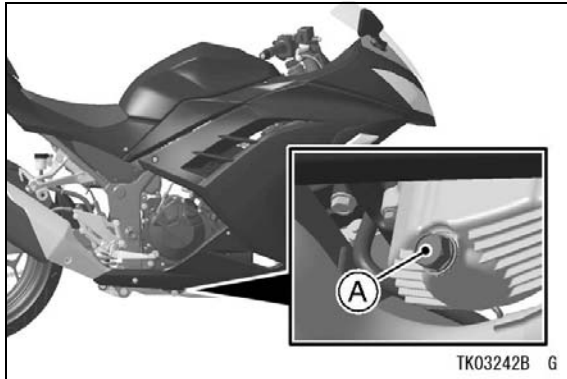

A. Engine Oil Drain Plug

- Park the vehicle on level ground.
- Before starting the engine, check that the engine has oil.
- With the motorcycle held level, check that the engine has oil through the oil level inspection window in the lower right side of the engine.

NOTICE

If the engine is run without oil, it will be severely damaged.

- Start the engine and run it for several minutes at idle speed. Stop the engine, then wait several minutes until the oil settles.
- With the motorcycle held level, check the engine oil level through the oil level inspection window. The oil level should come up between the upper and lower level lines next to the oil level inspection window.

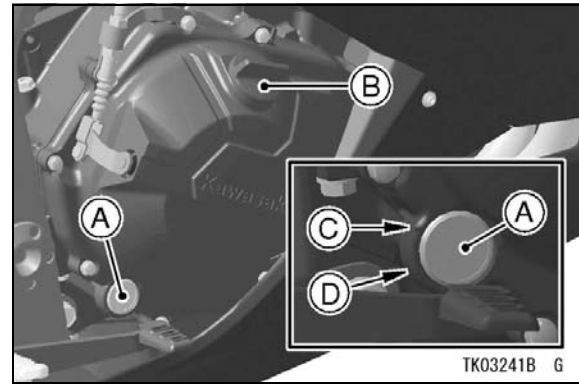

A. Oil Level Inspection Window

B. Oil Filler Cap

C. Upper Level Line

D. Lower Level Line

- If the oil level is too high, remove the excess oil through the oil filler opening, using a syringe or some other suitable device.
- If the oil level is too low, add oil to reach the correct level. Use the same type oil that is already in the engine.
- When replacing the cap, be sure the O-ring is in place, and tighten the cap in finger tight.

Recommended Engine Oil

Type: API SG, SH, SJ, SL or SM with JASO MA, MA1 or MA2

Viscosity: SAE 10W-40

Capacity: 2.0 L (2.1 US qt)

[when filter is not removed]

2.2 L (2.3 US qt)

[when filter is removed]

NOTE

○ Do not add any chemical additive to the oil. Oils fulfilling the above requirements are fully formulated and provide adequate lubrication for both the engine and the clutch.

Although 10W-40 engine oil is the recommended oil for most conditions, the oil viscosity may need to be changed to accommodate atmospheric conditions in your riding area.

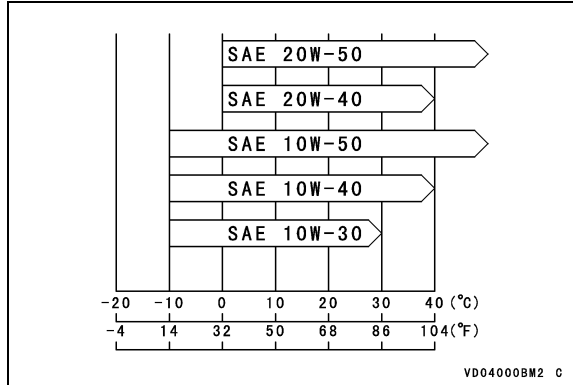

Idle Speed Adjustment

- Start the engine and warm it up thoroughly.
- Adjust the idle speed to 1 250 ~ 1 350 r/min (rpm) by turning the idle adjusting screw.

Idle Speed: 1 250 ~ 1 350 r/min (rpm)

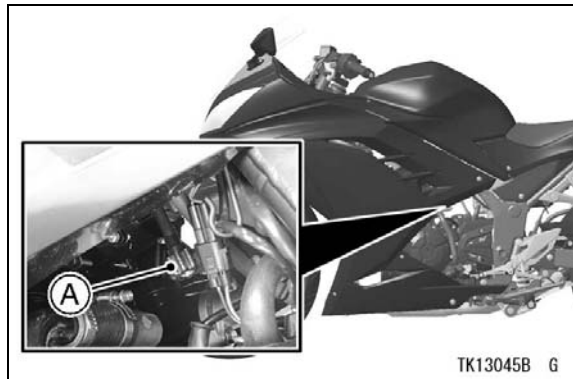

A. Idle Adjusting Screw

- Open and close the throttle grip a few times to make sure that the idle speed does not change.
- With the engine idling, turn the handlebar to each side. If handlebar movement changes the idle speed, check the throttle cable routing and free play.

⚠ WARNING

Operation with incorrectly routed or damaged throttle cable could result in an unsafe riding condition. Be sure the throttle cable is routed correctly, properly adjusted and is not damaged in any way.

- Check for any exhaust leaks and correct if necessary.

Throttle Grip and Cable

Throttle Grip Free Play Inspection

- Inspect the throttle grip free play. If the free play is incorrect, adjust the throttle cables.

Throttle Grip Free Play:

2 ~ 3 mm (0.08 ~ 0.12 in.)

- Check that the throttle grip moves smoothly from full open to close, and the throttle closes quickly and completely in all steering positions by the return spring. If the throttle grip does not return properly, check the throttle cable routing, grip free play, and for possible cable damage. Then lubricate the throttle cables.

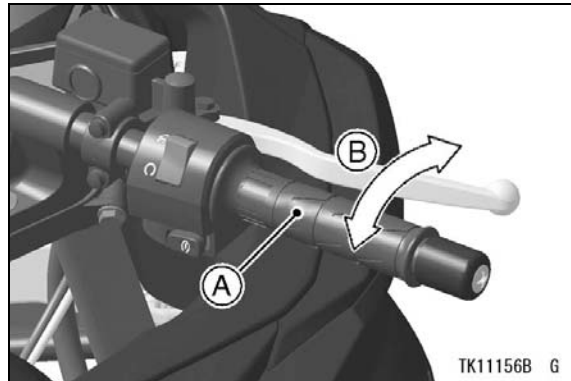

A. Throttle Grip

B. 2 ~ 3 mm (0.08 ~ 0.12 in.)

- Run the engine at idle speed, and turn the handlebar all the way to the right and left to ensure that the idle speed does not change. If the idle speed increases, check the throttle grip free play.

⚠ WARNING

Operation with incorrectly routed, improperly adjusted or damaged cables could result in an unsafe riding condition. Be sure the cables are routed correctly, properly adjusted and are not damaged in any way.

Throttle Grip Free Play Adjustment

- Loosen the locknut at the upper end of the throttle cable, and turn the throttle cable adjuster until the specified amount of play is obtained.
- Tighten the locknut.

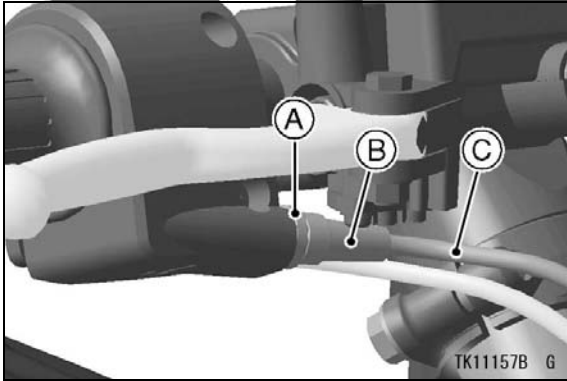

- A. Locknut
- B. Adjuster
- C. Throttle Cable (Accelerator Cable)

Rear Brake Light Switch

Rear Brake Light Switch Adjustment

- Turn on the ignition switch. The brake light should illuminate when the brake pedal is depressed about 10 mm (0.39 in.).
- If it does not, turn the adjusting nut at the rear brake light switch as required.

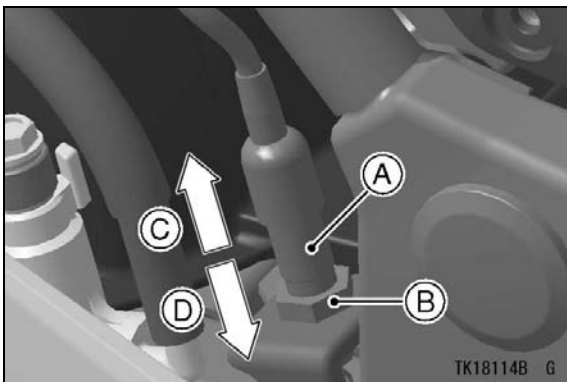

- A. Rear Brake Light Switch
- B. Adjusting Nut
- C. Lights sooner.
- D. Lights later.

NOTICE

To avoid damaging the electrical connections inside the switch, be sure that the switch body does not turn during adjustment.

Headlight Aim

The headlight beam is adjustable both horizontally and vertically. Headlight aim must be correctly adjusted for safe riding as well as on-coming drivers. In most areas it is illegal to ride with an improperly adjusted headlights.

The left and right (high beam and low beam) headlight aim can be adjusted individually.

Horizontal Adjustment

- Turn the horizontal adjuster in or out until the beam points straight ahead.

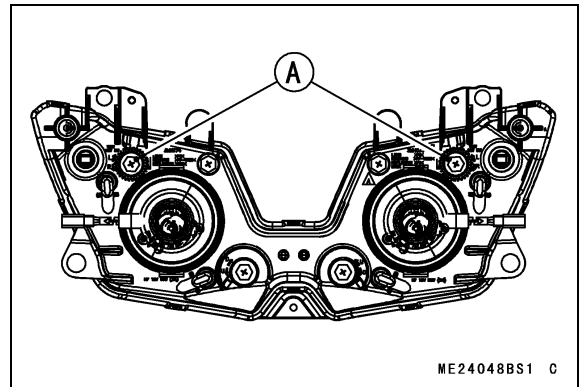

- A. Horizontal Adjusters

Vertical Adjustment

- Turn the vertical adjuster in or out to adjust the headlight vertically.

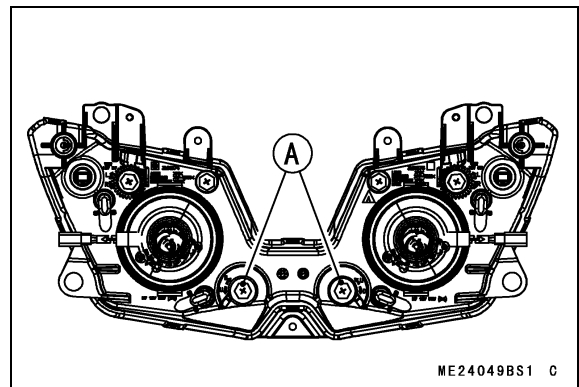

- A. Vertical Adjusters

For US and Canadian models:

NOTE

- On high beam, the brightest point should be slightly below horizontal. The proper angle is 0.4 degrees below horizontal. This is a 50 mm (2.0 in.) drop at 7.6 m (25 ft) measured from the center of the headlight, with the motorcycle on its wheels and the rider seated.

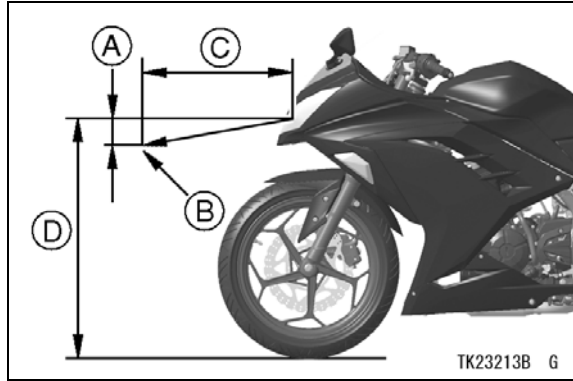

- A. 50 mm (2.0 in.)
- B. Center of Brightest Spot
- C. 7.6 m (25 ft)
- D. Height of Headlight Center

For other than US and Canadian models:

NOTE

○ On high beam, the brightest point should be slightly below horizontal with the motorcycle on its wheels and the rider seated. Adjust the headlight to the proper angle according to local regulation.

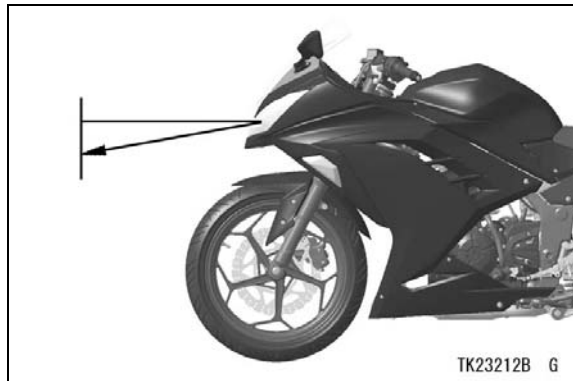

Digital Meter

Check the Display Unit Setting in the Digital Meter:

The display unit setting can alternate between mile and km modes in the digital meter. Make sure that mile or km is correctly displayed according to local regulations before delivering to your customer.

NOTE

○ Do not operate the vehicle with the digital meter displaying in the wrong unit (mile or km) of the digital meter. Shift the mile/km display in the digital meter as follows.

- Turn the ignition switch on.
- Select the Odometer display in the digital meter by pushing the left button.

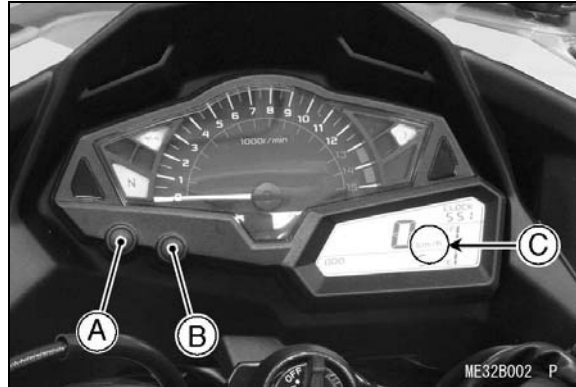

- A. Left Button
- B. Right Button
- C. Speed Unit Display

- Select the suitable display unit mode by pushing the right button while the left button pushed in.

License Plate Mounting Holes

The license plate mounting bracket at the rear end of the motorcycle has two holes where the license plate mounting bolts go through.

Original Mounting Bolt Holes:

Diameter: 7 mm (0.3 in.)

Center to center: 120 mm (4.72 in.)

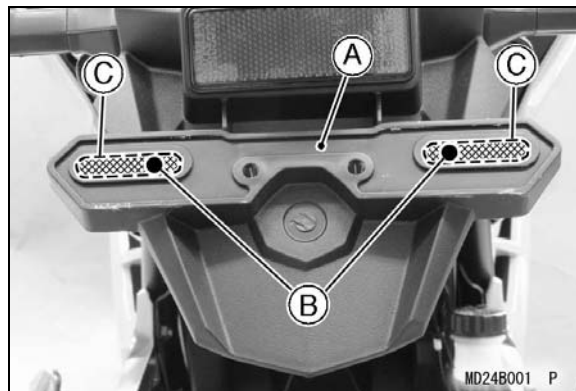

- A. License Plate Mounting Bracket
- B. Original Mounting Bolt Holes
- C. Recessed Mounting Hole Areas

In case the original mounting bolt holes would not fit to your license plate, drill new mounting holes [φ7 mm (0.3 in.)] in the recessed areas. New mounting holes should be symmetric to the motorcycle center.

This page intentionally left blank.

Fastener Check

- The torque values listed are for assembly and preparation items only, see the appropriate Service Manual for a more comprehensive list. Check tightness of all fasteners that are in the table before retail delivery. Also check to see that each cotter pin or circlip is in place.

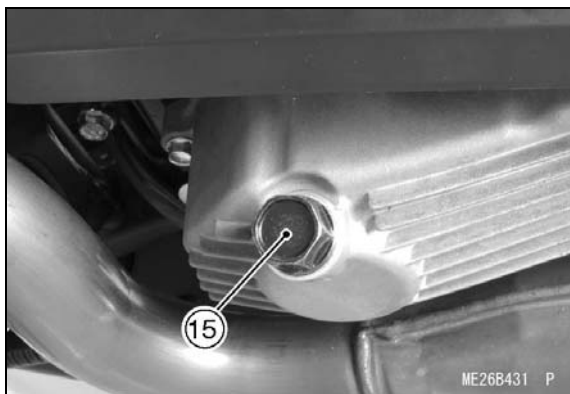
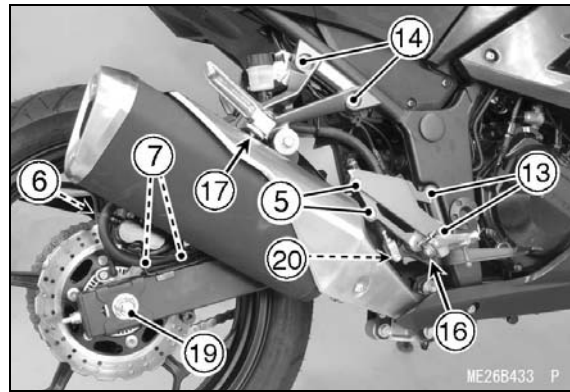
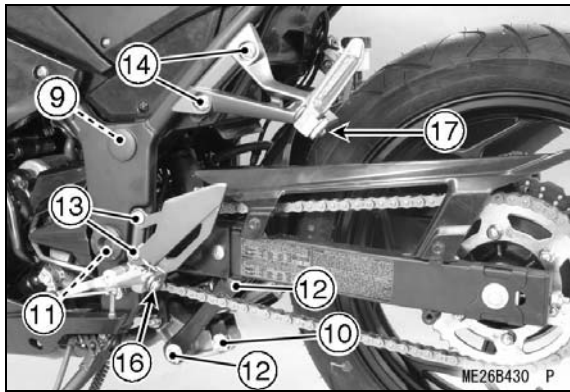
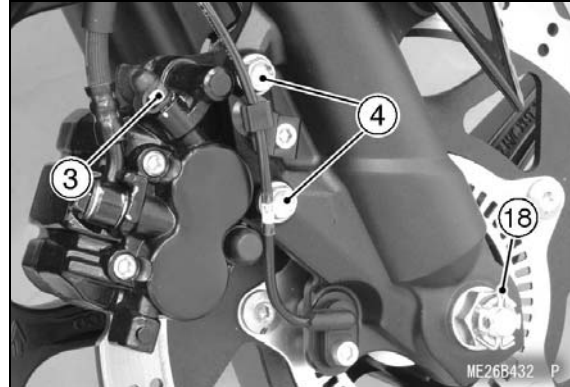
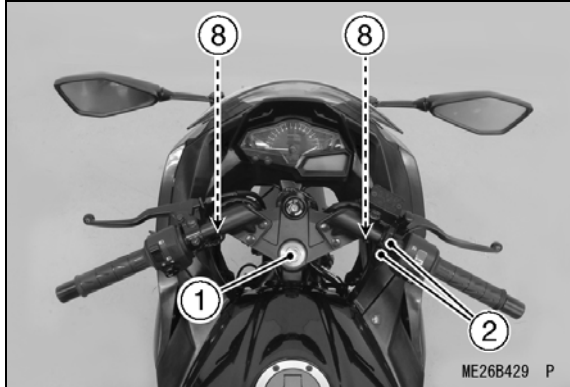

No.	Fastener	Torque			Remarks
		N·m	kgf·m	ft·lb	
Steering					
1	Steering stem head bolt	44	4.5	32	
Brake					
2	Front master cylinder clamp bolt	8.8	0.90	78 in·lb	S
3	Front brake bleed valve	5.5	0.56	49 in·lb	
4	Front caliper mounting bolt	25	2.5	18	
5	Rear master cylinder mounting bolt	25	2.5	18	
6	Rear brake bleed valve	5.5	0.56	49 in·lb	
7	Rear caliper mounting bolt	25	2.5	18	
Suspension					
8	Front fork clamp bolt (Upper) (Left and Right)	20	2.0	15	
9	Rear shock absorber mounting nut (Upper)	59	6.0	44	
10	Rear shock absorber mounting nut (Lower)	59	6.0	44	
11	Swingarm pivot shaft nut	98	10	72	
12	Rear suspension tie-rod nut	59	6.0	44	
Other					
13	Front footpeg bracket bolt (Left and Right)	25	2.5	18	
14	Rear footpeg bracket bolt (Left and Right)	25	2.5	18	
Engine Oil Drain Plug					
15	Engine oil drain plug	30	3.1	22	
Cotter Pin or Circlip					
16	Front footpeg pin circlip (Left and Right)	–	–	–	
17	Rear footpeg pin circlip (Left and Right)	–	–	–	
18	Front axle nut cotter pin	–	–	–	
19	Rear axle nut cotter pin	–	–	–	
20	Rear master cylinder cotter pin	–	–	–	

S: Tighten the upper clamp bolt first, and then the lower clamp bolt.

Standard Torque Table

This table relating tightening torque to thread diameter, lists the basic torque for bolts and nuts. Use this table for only the bolts and nuts which do not require a specific torque value. All of the values are for use with dry solvent-cleaned threads.

General Fasteners

Threads dia. (mm)	Torque		
	N·m	kgf·m	ft·lb
5	3.4 ~ 4.9	0.35 ~ 0.50	30 ~ 43 in·lb
6	5.9 ~ 7.8	0.60 ~ 0.80	52 ~ 69 in·lb
8	14 ~ 19	1.4 ~ 1.9	10.0 ~ 13.5
10	25 ~ 34	2.6 ~ 3.5	19.0 ~ 25
12	44 ~ 61	4.5 ~ 6.2	33 ~ 45
14	73 ~ 98	7.4 ~ 10.0	54 ~ 72
16	115 ~ 155	11.5 ~ 16.0	83 ~ 115
18	165 ~ 225	17.0 ~ 23.0	125 ~ 165
20	225 ~ 325	23.0 ~ 33.0	165 ~ 240

Test Ride the Motorcycle

- Complete the test ride checklist.

Control Cables:

Throttle cables must work without binding in any steering position.

Steering:

Action is free from lock-to-lock.

Suspension:

Check operation front and rear.

Engine:

Electric starter works properly and engine starts promptly. Good throttle response and return.

Transmission and Clutch:

Smooth operation.

Brakes:

Adequate, smooth stopping power, No drag.

Digital Meter:

Check operation.

Electrical System:

Headlight - Check high and low beams.

Taillight - Check operation.

Brake Light - Check operation.

Turn Signal Lights - Check operation.

Horn - Check operation.

Instrument Lights and Indicator Lights - Check operation.

Engine Stop Switch Works:

Starter Interlock Switch Works:

No Unusual Noises:

No Fuel, Oil, Brake Fluid, or Coolant Leaks:

PREPARATION COMPLETE.

⚠ WARNING

New tires are slippery and may cause loss of control and serious injury or death. A break-in period of 160 km (100 miles) is necessary to establish normal tire traction. During break-in, avoid sudden and maximum braking, acceleration, and hard cornering.

A & P Check List

- Complete the A & P Check List.

MODEL APPLICATION

Year	Model	Name
2013	EX300AD	Ninja 300
2013	EX300BD	Ninja 300 ABS
2014	EX300AE	Ninja 300
2014	EX300BE	Ninja 300 ABS
2015	EX300AF	Ninja 300
2015	EX300BF	Ninja 300 ABS
2016	EX300AG	Ninja 300
2016	EX300BG	Ninja 300 ABS
2017	EX300AH	Ninja 300
2017	EX300BH	Ninja 300 ABS