



RUSSIA, AUSTRALIA, BAHAMAS, BOLIVIA, BRAZIL, BELIZE, CANADA, CHILE, TAIWAN, COLOMBIA, COSTA RICA, DOMINICAN REPUBLIC, ECUADOR, EL SALVADOR, TRINIDAD AND TOBAGO, UNITED STATES, URUGUAY, VENEZUELA, MEXICO, ARUBA, NICARAGUA, PERU, PUERTO RICO, Curaçao, GUAM, GUATEMALA, GUYANA, HAITI, HONDURAS, JAMAICA, KOREA, SOUTH KOREA, NEW ZEALAND, PANAMA, SOUTH AFRICA

**Countries:** RUSSIA, AUSTRALIA, BAHAMAS, BOLIVIA, BRAZIL, BELIZE, CANADA, CHILE, TAIWAN, COLOMBIA, COSTA RICA, DOMINICAN REPUBLIC, ECUADOR, EL SALVADOR, TRINIDAD AND TOBAGO, UNITED STATES, URUGUAY, VENEZUELA, MEXICO, ARUBA, NICARAGUA, PERU, PUERTO RICO, Curaçao, GUAM, GUATEMALA, GUYANA, HAITI, HONDURAS, JAMAICA, KOREA, SOUTH KOREA, NEW ZEALAND, PANAMA, SOUTH AFRICA

**Document ID:** IK1201259

**Availability:** ISIS, Bus ISIS, FleetISIS

**Revision:** 8

**Major System:** ENGINES

**Created:** 1/20/2015

**Current Language:** English

**Last Modified:** 4/14/2016

**Other Languages:** NONE

**Author:** Aaron Mimbs

**Viewed:** 10324

[Less Info](#)

Hide Details

Coding Information

<b>Copy Link</b> 	<b>Copy Relative Link</b> 	<b>Bookmark</b>  <a href="#">View My Bookmarks</a>	<b>Add to Favorites</b> 	<b>Print</b> 	<b>Provide Feedback</b> 	<b>Helpful</b>  31	<b>Not Helpful</b>  5
----------------------	-------------------------------	--	-----------------------------	------------------	-----------------------------	--------------------------	-----------------------------

**Title:** MaxxFORCE 7 Fuel Dilution Diagnostics

**Applies To:** All MaxxFORCE 7

## CHANGE LOG

- 04/14/2016 - Removed retired documents and instructed to see the diagnostic manual
- 07/24/2015 - Added clause to Step 5 to skip forward to Step 9 in severe dilution situations
- 07/22/2015 - Updated Step 9 to reflect new HPFP removal procedure is for the 2010-2014 MaxxFORCE 7 only. Removed Step numbers from SRTs to alleviate confusion.
- 05/07/2015 - Clarified diagnostic steps and figure numbers, added exhaust system gasket part numbers

## DESCRIPTION

This document will guide the user through step based diagnostics for fuel in the oil.

This document replaces/retires: IK1200990

## SYMPTOMS

### Diagnostic Trouble Codes:

#### 2007 - 2009 MaxxFORCE 7

DTC/Light	Description
SPN 100 FMI 1	EOP below warning level
SPN 100 FMI 7	EOP below critical level

#### 2010 - 2013 MaxxFORCE 7

DTC/Light	Description
SPN 100 FMI 1	Engine Oil System below Critical Pressure
SPN 100 FMI 18	Engine Oil System below Warning Pressure

### Customer Observations or Concerns:

1. Low Oil Pressure
2. Increasing Oil Level
3. Black Smoke
4. Excessive Oil Carry Over into Intake
5. High Crankcase Pressure
6. Engine Vibration

- 7. Loss of Power
- 8. MIL
- 9. Excessive Regenerations

## **SPECIAL TOOLS / SOFTWARE**

Tool Description	Tool Number	Comments	Instructions
SERVICEMAXX OR POCKETMAXX			
PRESSURE TEST KIT	ZTSE4409		
FITTING FUEL FILTER	1841403C1	FITTING AND O-RING QUICK CONNECT (10mm)	Used to connect the pressure test kit to the oil pressure port on the oil pan
CLEAN PAPER TOWELS	LOCALLY		
PACKAGING TAPE	LOCALLY		
CLEAN FUEL SOURCE TOOL	15-637-01		
BLACK LIGHT	LOCALLY		
CUMMINS FLUID DYE	LOCALLY		

## **SERVICE PARTS INFORMATION**

### 2007-2009 MaxxForce 7

Kit Description	Part Number	Quantity Required	Notes
KIT, INJECTOR REMAN, INTL	4307381R91	0 - 8	Injector Kit
TUBE ASSY FUEL RAIL TO INJCTR	1886547C1	0 - 8	Tube Only
RING, "O" SPECIAL .886" X .998"	1834166C1	0 - 8	Injector O-Ring Only
GASKET, COMBUSTION	1855345C1	0 - 8	Injector Combustion Gasket
KIT, HP FUEL PUMP REMAN INTL	4307291R91	1	
SENSOR ASM, RAIL PRESSURE FUEL	1873400C92	1	
TUBE ASSY PUMP RIGHT	1881361C1	1	HPFP to Right Rail
TUBE ASSY PUMP LEFT	1881375C1	1	HPFP to Left Rail

### 2010 - 2013 MaxxForce 7

Kit Description	Part Number	Quantity Required	Notes
KIT INJECTOR	1899239C92	0 - 8	Injector Kit
TUBE ASSY FUEL RAIL TO INJCTR	1886547C1	0 - 8	Tube Only
RING, "O" SPECIAL .886" X .998"	1834166C1	0 - 8	Injector O-Ring Only
GASKET, COMBUSTION	1855345C1	0 - 8	Injector Combustion Gasket
KIT, FUEL PUMP HIGH PRESSURE W/HARNESS	7080839C93	1	Includes Pump Harness
SENSOR ASM, RAIL PRESSURE FUEL	1873400C92	1	
TUBE ASSY RIGHT FUEL HIGH PRES	1883147C1	1	HPFP to Right Rail
TUBE ASSY LEFT FUEL HIGH PRESS	1883148C1	1	HPFP to Left Rail
FUEL PUMP SEAL KIT	1899241C93	1	
CROSSOVER TUBE O-RINGS	1841625C1	3	
TURBO/EGR COOLER INLET GASKET	1878460C1	2	

Exhaust/Aftertreatment Seals and Components

Kit Description	Part Number	Qty	Notes
GASKET TAPE EXHAUST 3/4"X36YDS	2604051C91	1	Heat resistant exhaust flange tape
GASKET,EXH PIPE FLANGE	1891515C1	1 - 2	Turbo outlet and down pipe extension gaskets
GASKET V-BAND TURBO	1883660C1	1 - 2	Exhaust Up-Pipe to X-Pipe O-Gaskets
GASKET, EXHAUST SINGLE LAYER	1875808C1	1 - 2	Exhaust Manifold to Up-Pipe Gaskets
GASKET TURBO INLET	1878460C1	2	Turbo/EGR Cooler Inlet Gaskets
GASKET DUAL PORT	1877824C1	1	Center Exhaust Manifold Gasket (1 of 3)
GASKET SINGLE PORT	1877823C1	2	Outside Exhaust Manifold Gasket (2&3 of 3)
DPF ASSEMBLY	2510963C1	1	Terrastar DPF Assembly (Verify Specific Application Before Ordering)
DPF KIT REPLACEMENT 11.25X12	1892211C91	1	DPF Replacement Kit (4300) (Verify Specific Application Before Ordering)
GASKET, FLANGE OFFSET 3 HOLE	2593986C1	1	DPF Outlet Gasket (4300)
GASKET, FLANGE 3 BOLT	2593998C1	1	DPF Inlet Gasket (4300)

**DIAGNOSTIC STEPS**

**WARNING**

To prevent personal injury or death, shift transmission to park or neutral, set parking brake, and block wheels before doing diagnostic or service procedures.

**WARNING**

To prevent personal injury or death, make sure the engine has cooled before removing components.

**WARNING**

To prevent personal injury or death, do not let engine fluids stay on your skin. Clean skin and nails using hand cleaner and wash with soap and water. Wash or discard clothing and rags contaminated with engine fluids.

**WARNING**

To prevent personal injury or death, read all safety instructions in the "Safety Information" section of the diagnostic manuals.

**WARNING**

These diagnostics require running the engine with cover(s) removed exposing moving components. Glasses are required due to oil splash and do not touch moving components.

Step	Action	Decision
1	Generate a Health Report	Yes. Step 2
	Was the health report successful?	No. Resolve, Step 2

Step	Action	Decision
------	--------	----------

<b>2</b>	<b>Verify calibration.</b>  Is the calibration up-to-date?	<b>Yes.</b> Step 3
		<b>No.</b> Update Calibration. Step 3

Step	Action	Decision
<b>3</b>	<b>Perform visual checks per Diagnostic Manual and/or Performance Diagnostic sheet.</b>  1. Inspect Fuel System to Verify Fuel Level 2. Inspect Engine Oil Level 3. Inspect Coolant Recovery Bottle for Coolant Level 4. Inspect Electrical Group for Poor or Loose Connections 5. Inspect Air Filter Minder 6. Inspect Exhaust System  Any issues noted?	<b>Yes.</b> Correct the issue(s). If the oil level is over full, drain it to a proper level and take a sample for analysis.  Otherwise continue to Step 4.  <b>No.</b> If the oil level is normal, has no signs of dilution, and the complaint is low pressure, see Diagnostic Trouble Shooting Procedures, Lubrication System, Low Oil Pressure in the Diagnostic Manual.

Step	Action	Decision
<b>4</b>	<b>Inspect engine operation.</b>  Does the engine run rough with a corrected oil level?	<b>Yes.</b> See Engine System Tests and Inspections, Cylinder Performance Analyzer Tests in the Diagnostic Manual.  <b>No.</b> Step 5

Step	Action	Decision
<b>5</b>	<b>Disclose oil service habits from the customer and compare to the Operator Manual service recommendation.</b>  <b>2007-2009 MaxxFORCE 7:</b> 10,000 Miles or 350 hours, which ever comes first.  <b>2010-2013 MaxxFORCE 7:</b>  Fuel Economy is less than 7 MPG: Every 7,000 miles  Fuel Economy is greater than 7 MPG but less than 11 MPG: Miles = (2000 X MPG) - 7000 Ex. MPG = 8.2     2000(8.2) - 7000 = 9,400 miles  Fuel Economy > 11MPG: Every 15,000 Miles  <b>ALL MODELS:</b> If the dilution concern is severe (ex. Step 3 oil was drastically overfull and extremely thin) continue to Step 9 and begin fuel system dye testing. After repairing the leaking component and reassembling the engine please perform Steps 6, 7, and 8 to verify the repair.	<b>1.</b> Current Oil life is within limits and customer is following interval requirements.  Step 6  <b>2.</b> Current Oil life is within limits but the customer is not following interval requirements.  Inform the customer of the proper service interval for their application and continue to  Step 6  <b>3.</b> Current Oil life is beyond the service limits and the customer is not following interval requirements.  Get customer approval to change the oil out of warranty expense. Return the truck to the customer and monitor the oil level. If the oil level rises in an unreasonable amount, the truck must be diagnosed further. Send the oil sample out for testing and documentation.  Remember oil expands when heated, if the oil level is checked cold, it will need to be rechecked cold.

Step	Action	Decision
<b>6</b>	<b>Inspect AMS and Exhaust System for Leaks</b>  See <a href="#">IK1201142 Leak Locater Diagnostic Procedures</a> . Tighten all AMS pressure clamps to 115lb-in.  Were any issues noted?	<b>Yes.</b> Correct the leaks, use the above listed gaskets and exhaust tape to prevent leaks in the Service Parts Information Section ( <a href="#">Click Here</a> ). Step 7  <b>No.</b> Step 7

Step	Action	Decision
7	<p><b>Perform aftertreatment cleaning.</b></p> <p>Warning: Move the vehicle outside before performing this step.</p> <p><b>2010 - 2013 MaxxFORCE 7:</b> Perform an On Board Filter Cleanliness Test in ServiceMaxx and record it.</p> <p>See the <a href="#">V-8 DPF and DOC Catastrophic Failure Performance Assessment Sheet</a> and evaluate the regeneration.</p> <p>OR</p> <p><b>2007-2009 MaxxFORCE 7:</b> Perform a DOC Cleaning See <a href="#">IK1200478</a></p> <p>EGT1 (DOC Inlet) must reach above 950F</p> <p>Were the procedures successful?</p>	<p><b>Yes.</b> Step 8</p> <p><b>No.</b> Attempt procedure again. If the results are the same, diagnose the aftertreatment temperature sensors and remove the aftertreatment. Bake and blow out the DPF, clean the face of the DOC, and blow out the DPFDP sensor tubes. Reinstall everything and inspect for leaks. Attempt procedure again. If the results are the same, open a case file with Navistar's Technical Support group with all relevant information and recordings for further evaluation.</p> <p>Continue to Step 8</p>

Step	Action	Decision
8	<p><b>Road test vehicle.</b></p> <p>While hot and the engine OFF, mark the oil level on the dipstick. Road test for 30 miles (preferable highway loading). Also record a 0-60 full throttle snapshot in ServiceMaxx. Allow the engine to cool down and recheck the oil level.</p> <p><b>2010 - 2013 MaxxFORCE 7:</b> For Performance Analysis see the Diagnostic Manual</p> <p><b>2007-2009 MaxxFORCE 7:</b> Note engine performance and sound, analyze snapshot, and verify boost is within specification (typically 20-25psi). If lower than expected, remove and clean the IMP and EBP sensor and tubes--reassemble and recheck performance. EBP and MAP sensor voltage readings at KOEO should be equal and roughly 0.76V in the continuous monitor session.</p>	<p><b>1.</b> Oil did not rise; engine performance is good.</p> <p>Release to the customer for monitoring. Send the oil sample out for testing and documentation.</p> <p><b>2.</b> Oil did not rise; engine performance is not good.</p> <p>Diagnose low power complaint; keep in mind truck weight, loading, and grading. Once complete, release the unit to the customer for monitoring. Send the oil sample out for testing and documentation.</p> <p><b>3.</b> Oil level has risen, engine performance is not good.</p> <p>Diagnose and repair low power complaint; keep in mind truck weight, loading, and grading. Return to Step 7</p> <p><b>4.</b> Oil level has risen; engine performance is good.</p> <p>Step 9</p>

Step	Action	Decision
9	<p><b>Inspect for fuel leaks.</b></p> <p>1. Hook up the clean fuel source with heavily saturated and mixed dyed diesel fuel (use Cummins' Dye). Create a test spot of fuel/dye to make sure it illuminates under a black light. If desired add more dye.</p> <p>2. Run the engine for 5 minutes and monitor fuel consumption. Open the manual drain valve on the fuel filter module and inspect fuel with a black light. Make sure it illuminates sufficiently.</p> <p>3. Remove the High Pressure Fuel Pump cover. (2010-2014 MaxxFORCE 7 follow elemental SRT steps for NEW procedure. The turbochargers can remain on the engine.)</p> <p>4. Reassemble the fuel lines temporarily for diagnostic purposes. The steel HPFP supply lines are crush fit, meaning one time use only. They must be replaced after diagnostics are complete.</p> <p>5. Clean off the pump using brake cleaner to remove any remaining dye/fuel. Inspect the pump with a black light for remaining traces of dye and remove if necessary.</p>	<p><b>Yes.</b> Double check with a coworker or manager. If the pump is still determined leaking, replace the HPFP and harness.</p> <p><b>On the failed pump, please circle the leak location with a paint pen for warranty review.</b></p> <p>Reassemble the engine; return to Step 7.</p> <p><b>No.</b> Reassemble the engine and pump cover. Step 10</p>

6. The pump cover can be left off or rested over the pump to help contain the oil.
7. Run the Standard test in ServiceMaxx and perform a few brake stalls to raise FRP.
8. After sufficient FRP has been built and sufficient time has gone by to cycle the dyed fuel through the system, shut the engine down and use a black light to inspect the pump for fuel/dye. See Figure 1 below for most likely leak locations. Use a small mirror to inspect hard to see locations.

**NOTE:** Engine oil has a natural luminous glow to it under a black light. If unsure the glow is dye, drain a small amount of fuel from the manual drain valve on the fuel filter module and inspect with a black light. Make sure the fuel glows. A test spot of dyed fuel on the pump can help determine if it is properly illuminating under black light.

Were any fuel leaks found?

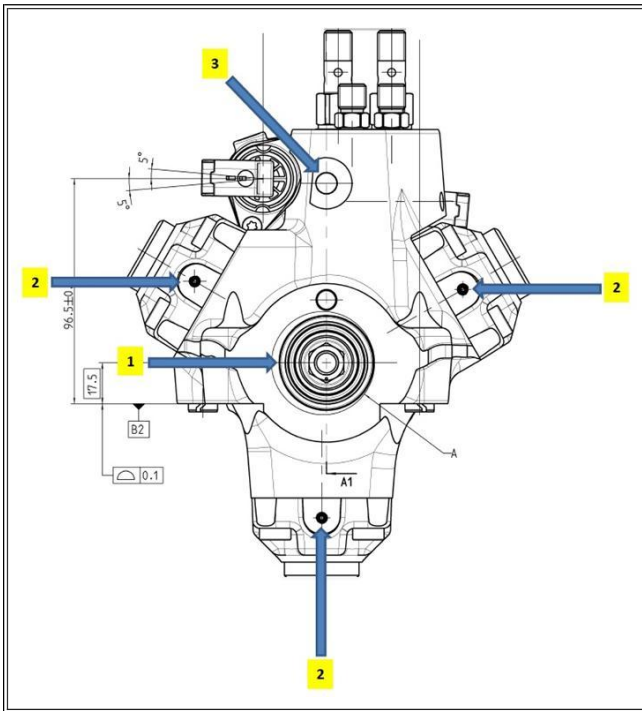

**Figure 1: Ranked High Pressure Fuel Pump Leak Locations**

1. HPFP Shaft Seal
2. Pump Cylinder Expander Screws
3. Pressure Relief Valve

**ATTENTION**

Do NOT replace an injector unless it is confirmed to have a body leak. If a leak is found at the jumper tube, replace ONLY that tube.

Step	Action	Decision
10	<p><b>Inspect for fuel leaks.</b></p> <p>With the dyed clean fuel source still connected.</p> <ol style="list-style-type: none"> <li>1. Remove the PASSENGER side valve cover. Reassemble other components as needed to operate the engine with the cover removed.</li> <li>2. Spray, clean, and dry the high pressure fuel connections (brake cleaner works well). Wrap the high pressure fuel connections and the FRP sensor with clean paper towels and secure with tape (this will also help prevent oil contamination).</li> <li>3. The valve cover can be left off or rested in place to prevent oil splash.</li> <li>4. Run the Standard Test in ServiceMaxx and perform a few brake stalls to raise FRP</li> </ol>	<p><b>Yes.</b> Repair leaks and torque everything to specification, per the Engine Service Manual. Rerun the dye test. If all is well, reassemble the engine and return to Step 7.</p> <p>If the FRP sensor is leaking replace it. Once removed, make sure the compression gasket is in place see Figure 3 below.</p> <p><b>NOTE:</b> The fuel rail must be replaced if the FRP sensor continues to leak after replacement.</p> <p><b>No.</b> Step 11</p>

5. After sufficient FRP has been built, and time has gone by to cycle the dyed fuel through the system, shut the engine down and one at a time, remove the paper towels inspect them with a black light for dyed fuel or wetness. See Figures 2, and 3 below for most likely leak locations.

6. Inspect around the base of the injectors for any signs of fuel leaking past the o-rings. See Figure 4 for most likely leak locations.

**NOTE:** It is possible but very unlikely that the injector body o-rings will leak. These o-ring are under very little pressure (MAX 5 psi). The most likely leak locations are at the high pressure fittings and connections.

Were any fuel leaks found?

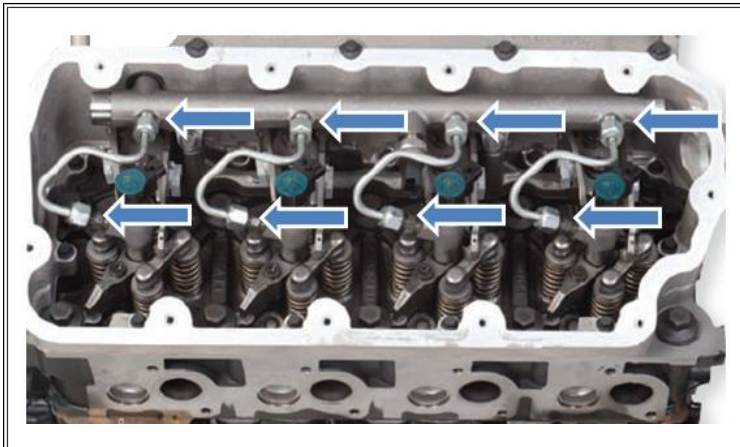

Figure 2: Injector Jumper Tube Leak Locations



Figure 3: FRP Sensor and Compression Gasket

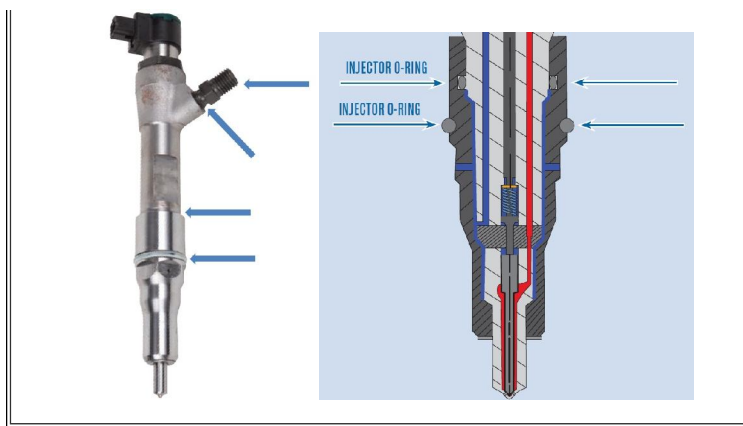

Figure 4: Injector Leak Locations

Step	Action	Decision
11	<p><b>Inspect for fuel leaks.</b></p> <ol style="list-style-type: none"> <li>Remove the DRIVER's side valve cover. Reassemble other components as needed to operate the engine.</li> <li>Spray and clean the high pressure fuel connections. Wrap the high pressure fuel connections with clean paper towels and secure with tape (this will also prevent oil contamination).</li> <li>The valve cover can be left off or rested in place, to prevent oil splash.</li> <li>Run the Standard test in ServiceMaxx and perform a few brake stalls to raise FRP</li> </ol> <p>6. After sufficient FRP has been built and time has gone by to cycle the dyed fuel through the system, shut the engine down and one at a time remove the paper towels inspect them with a black light for dyed fuel or wetness. See Figure 2 above for most likely leak locations.</p> <p>7. Inspect around the base of the injectors for any signs of fuel leaking past the o-rings. See Figure 4 for most likely leak locations.</p> <p><b>NOTE: It is possible but very unlikely that the injector body o-rings will leak. These o-ring are under very little pressure (MAX 5 psi). The most likely leak locations are at the high pressure fittings and connections.</b></p> <p>Were any fuel leaks found?</p>	<p><b>Yes.</b> Repair Leaks and torque everything to specification per the Engine Service Manual. Reassemble the engine and return to Step 7.</p>
	<p><b>No.</b> Step 12</p>	

Step	Action	Decision
12	Reassemble the engine and release to the customer to monitor dilution.	Diagnostics complete.

## REPAIR STEPS

See appropriate engine service manuals for removal and installation procedure.

2007 - 2009 MaxxFORCE 7: [Engine Service Manual](#)

2010 - 2013 MaxxFORCE 7: [Engine Service Manual](#)

## WARRANTY INFORMATION

Warranty Claim Coding:



<b>Group:</b>	12000 - ENIGNES
<b>Noun:</b>	716 - Reprogram Engine - Calibration
	792 - Injector Fuel Lines (High PSI)
	563 - Injector Unit (Electrical)
	562 - O-Ring, Injector Unit
	454 - Pump, Oil/Fuel (High Pressure System)
	858 - Converter, Catalytic (Diesel Oxidation) (DOC)
	235 - Diesel Particulate Filter (DPF)

**Standard Repair Times:****2007 - 2009 MaxxFORce 7**

Description	Chassis	Engine	SRT	Hours
Update Engine Calibration	ALL	MaxxFORce 7	<a href="#">A12-3510J</a>	0.4
Health Report and DTC	ALL	MaxxFORce 7	<a href="#">SEE MANUAL</a>	
Visual Inspections	ALL	MaxxFORce 7	<a href="#">SEE MANUAL</a>	
Misfire Diagnostics		MaxxFORce 7	SEE <a href="#">IK1201222</a>	
AMS Leak Testing		MaxxFORce 7	SEE <a href="#">IK1201142</a>	
DOC Cleaning		MaxxFORce 7	<a href="#">SEE MANUAL</a>	
Diesel Particulate Filter R&R		MaxxFORce 7	<a href="#">SEE MANUAL</a>	
Diesel Oxidation Catalyst R&R		MaxxFORce 7	<a href="#">SEE MANUAL</a>	
Road Test		MaxxFORce 7	<a href="#">SEE MANUAL</a>	
Valve Cover R&R		MaxxFORce 7	<a href="#">SEE MANUAL</a>	
Dye Testing Prep and Check	ALL	MaxxFORce 7	T-Time	0.4
Injector Replacement (Each Additional Cylinder)	ALL	MaxxFORce 7	<a href="#">SEE MANUAL</a>	0.2
FRP Sensor Replace		MaxxFORce 7	<a href="#">SEE MANUAL</a>	
HPFP Cover R&R		MaxxFORce 7	<a href="#">SEE MANUAL</a>	
HPFP Cleaning and Dye Testing	ALL	MaxxFORce 7	T-Time	0.2
HPFP Replace (Includes Cover R&R)		MaxxFORce 7	<a href="#">SEE MANUAL</a>	

**2010 - 2013 MaxxFORce 7**

Description	Chassis	Engine	SRT	Hours
Update Engine Calibration	ALL	2010 Emissions MF7	<a href="#">A12-3510X</a>	0.4
Health Report and DTC	ALL	2010 Emissions MF7	<a href="#">SEE MANUAL</a>	
Visual Inspections	ALL	2010 Emissions MF7	<a href="#">SEE MANUAL</a>	
Misfire Diagnostics		2010 Emissions MF7	SEE <a href="#">IK1201222</a>	
AMS Leak Testing		2010 Emissions MF7	SEE <a href="#">IK1201142</a>	
OBFC	ALL	2010 Emissions MF7	<a href="#">A12-7235A-20</a>	0.3
Diesel Particulate Filter R&R		2010 Emissions MF7	<a href="#">SEE MANUAL</a>	
Diesel Oxidation Catalyst R&R		2010 Emissions MF7	<a href="#">SEE MANUAL</a>	
Road Test		2010 Emissions MF7	<a href="#">SEE MANUAL</a>	
Valve Cover R&R		2010 Emissions MF7	<a href="#">SEE MANUAL</a>	
Dye Testing Prep and Check	ALL	2010 Emissions MF7	T-Time	0.4
Injector or Tube Replacement (Each Additional Cylinder)	ALL	2010 Emissions MF7	<a href="#">SEE MANUAL</a>	0.2
FRP Sensor Replace		2010 Emissions MF7	<a href="#">SEE MANUAL</a>	
HPFP Cover R&R		2010 Emissions MF7	<a href="#">SEE MANUAL</a>	
HPFP Cleaning and Dye Testing	ALL	2010 Emissions MF7	T-Time	0.2
HPFP Replace (Includes Cover R&R)		2010 Emissions MF7	<a href="#">SEE MANUAL</a>	

**OTHER RESOURCES**

[Master Service Information Site](#)

 Hide Details

Feedback Information

Viewed: 10323

Helpful: 31

Not Helpful: 5

No Feedback Found