

# 2017 PRE-DELIVERY SERVICE CHECK SHEET

Market: USA

August 2016

BEFORE INSPECTION	OK	Adjust Repair
1 Install D/C Cut Fuse* (see page 2).....	<input type="checkbox"/>	
<b>FUNCTIONAL OPERATION</b>		
<i>Apply parking brake and cycle ignition "IG-ON"; place gear selector in reverse; turn on lights and rear defogger. Unlock all doors, release fuel door, release trunk hatch.</i>		
1 Check dome, courtesy, map, and sun visor lights*.....	<input type="checkbox"/>	<input type="checkbox"/>
2 Check warning/indicator lights, gauges, and horn.....	<input type="checkbox"/>	<input type="checkbox"/>
3 Check windshield wipers and washers.....	<input type="checkbox"/>	<input type="checkbox"/>
4 Check headlights, instrument lights, turn signals, emergency flashers, and brake lights.....	<input type="checkbox"/>	<input type="checkbox"/>
5 Check inside/outside rear view mirror operation/adjustment.....	<input type="checkbox"/>	<input type="checkbox"/>
6 Check cigarette lighter* and power outlets.....	<input type="checkbox"/>	<input type="checkbox"/>
7 Check audio/navigation*/backup camera* systems and set clock.....	<input type="checkbox"/>	<input type="checkbox"/>
8 Check sliding roof*.....	<input type="checkbox"/>	<input type="checkbox"/>
9 Install shift-lock override button cover.....	<input type="checkbox"/>	
<b>WALKAROUND INSPECTION</b>		
<i>Start at left front door. Check window and door lock operation (from master power switch, if equipped). Continue around vehicle in a counterclockwise direction checking each door and window operation, child door locks, seat belts, interior condition, all lights, luggage compartment contents. Finish by checking headlight aim and continue into UNDER HOOD checks.</i>		
1 <b>Check Smart Key System</b> .....	<input type="checkbox"/>	<input type="checkbox"/>
2 Check door and door lock operation, including each wireless remote control/theft deterrent system*.....	<input type="checkbox"/>	<input type="checkbox"/>
3 Check window operation.....	<input type="checkbox"/>	<input type="checkbox"/>
4 Check that engine starts with all keys.....	<input type="checkbox"/>	<input type="checkbox"/>
5 Check that child safety door locks are in normal (unlocked) position.....	<input type="checkbox"/>	<input type="checkbox"/>
6 Check seats and seat belt operation.....	<input type="checkbox"/>	<input type="checkbox"/>
7 Check rear defogger/rear view mirror defogger*.....	<input type="checkbox"/>	<input type="checkbox"/>
8 Check side marker, tail, backup, and license plate lights.....	<input type="checkbox"/>	<input type="checkbox"/>
9 Check luggage compartment light* and trim appearance.....	<input type="checkbox"/>	<input type="checkbox"/>
10 Adjust spare tire pressure, inspect for damage, and check jack and tool installation.....	<input type="checkbox"/>	<input type="checkbox"/>
11 Check headlight aim.....	<input type="checkbox"/>	<input type="checkbox"/>
<b>UNDER HOOD</b>		
1 Check engine oil and ATM* fluid levels.....	<input type="checkbox"/>	<input type="checkbox"/>
2 Check brake and clutch* fluid levels.....	<input type="checkbox"/>	<input type="checkbox"/>
3 Check engine coolant level.....	<input type="checkbox"/>	<input type="checkbox"/>
4 Check windshield washer fluid level.....	<input type="checkbox"/>	<input type="checkbox"/>
5 <b>Check battery State-Of-Charge using Digital Battery System Analyzer (SOC Reading: _____%)</b> .....	<input type="checkbox"/>	<input type="checkbox"/>
6 Inspect for fuel, oil, coolant, and other fluid leaks.....	<input type="checkbox"/>	<input type="checkbox"/>
Notes:		

UNDER VEHICLE (ON HOIST)	OK	Adjust Repair
1 <b>Remove disc brake anti-rust covers/anti-corrosion wheel film* (remove just prior to customer delivery)....</b>	<input type="checkbox"/>	
2 Inspect tires for defects/damage.....	<input type="checkbox"/>	<input type="checkbox"/>
3 Initialize Tire Pressure Warning System (TPWS) (see page 2).....	<input type="checkbox"/>	<input type="checkbox"/>
4 Install wheel covers/caps/spare tire wheel covers*.....	<input type="checkbox"/>	<input type="checkbox"/>
5 Inspect for fuel, oil, coolant, and other fluid leaks.....	<input type="checkbox"/>	<input type="checkbox"/>
6 Inspect under the vehicle for damage, rust, etc.....	<input type="checkbox"/>	<input type="checkbox"/>
7 Visually check bolts and nuts on chassis and powertrain for looseness.....	<input type="checkbox"/>	<input type="checkbox"/>
8 Install rubber body plugs (stored in glove box or center console)*.....	<input type="checkbox"/>	
<b>ROAD TEST</b>		
<i>A complete road test helps assure customer satisfaction. Drive vehicle over a variety of road surfaces and driving conditions. Check for unusual noise and driving performance.</i>		
<b>Enter Odometer Readings</b>		
Reading Before Test: _____ Reading After Test: _____		
1 Check cold engine operation.....	<input type="checkbox"/>	<input type="checkbox"/>
2 Check engine operation during warm-up.....	<input type="checkbox"/>	<input type="checkbox"/>
3 Check engine operation at normal operating temperature.....	<input type="checkbox"/>	<input type="checkbox"/>
4 Check clutch or transmission operation.....	<input type="checkbox"/>	<input type="checkbox"/>
5 Check brake and parking brake operation.....	<input type="checkbox"/>	<input type="checkbox"/>
6 Check steering operation and off-center/vehicle pull/flutter..	<input type="checkbox"/>	<input type="checkbox"/>
7 Inspect for abnormal noise and vibration.....	<input type="checkbox"/>	<input type="checkbox"/>
8 Inspect for squeaks and rattles.....	<input type="checkbox"/>	<input type="checkbox"/>
9 Check heater and A/C operation.....	<input type="checkbox"/>	<input type="checkbox"/>
10 Check cruise control operation*.....	<input type="checkbox"/>	<input type="checkbox"/>
11 Check front seat heater operation*.....	<input type="checkbox"/>	<input type="checkbox"/>
12 Set/calibrate compass* (see page 2).....	<input type="checkbox"/>	<input type="checkbox"/>
<b>FINAL INSPECTION AND CLEANING</b>		
1 Remove interior protective covers, unnecessary labels, tags, etc. (Remove just before delivery to customer).....	<input type="checkbox"/>	<input type="checkbox"/>
2 Visually inspect all interior parts for installation, damage, fit, dirt, etc.....	<input type="checkbox"/>	<input type="checkbox"/>
3 <b>Verify floor mat application and install using retaining clips*</b> .....	<input type="checkbox"/>	<input type="checkbox"/>
4 Remove Rapgard™ and clear protective bumper film*.....	<input type="checkbox"/>	<input type="checkbox"/>
5 Wash and clean vehicle.....	<input type="checkbox"/>	<input type="checkbox"/>
6 Inspect paint finish for scratches, chips, rust, dents, damage, etc.....	<input type="checkbox"/>	<input type="checkbox"/>
7 Inspect exterior body parts for proper installation, damage, rust, etc.....	<input type="checkbox"/>	<input type="checkbox"/>
8 Place oil change sticker on inside of windshield, top left corner.....	<input type="checkbox"/>	<input type="checkbox"/>
9 Place Owner's Manual portfolio* in glove box.....	<input type="checkbox"/>	<input type="checkbox"/>
10 Perform Techstream Health Check.....	<input type="checkbox"/>	<input type="checkbox"/>
11 Install front license plate and mounting bracket* (see page 2).....	<input type="checkbox"/>	<input type="checkbox"/>
<b>* Inspect or install when equipped/required.</b>		

Completion and retention of this form is required to comply with Toyota's Warranty Policy.

 \_\_\_\_\_  
 TECHNICIAN'S SIGNATURE

 \_\_\_\_\_  
 SERVICE MANAGER'S SIGNATURE

 \_\_\_\_\_  
 NAME (PLEASE PRINT)

 \_\_\_\_\_  
 NAME (PLEASE PRINT)

**We hereby certify that all items on this form have been checked and corrected for proper operation as required.**

Date

Dealer Name

Dealer Code

Vehicle Identification Number (Sticker)

## D/C CUT FUSE INSTALLATION

To minimize battery discharge the D/C Cut Fuse has been removed and is stored in the engine compartment Relay Block. Install the D/C Cut Fuse and confirm ALL related DTCs are cleared.

### DTC Clearing Procedure

1. Connect Techstream.
2. Cycle the ignition switch to the "IG-ON" position.
3. Using Techstream, check ANY other codes being output.
4. Erase DTCs (B1247) and Freeze Frame Data.

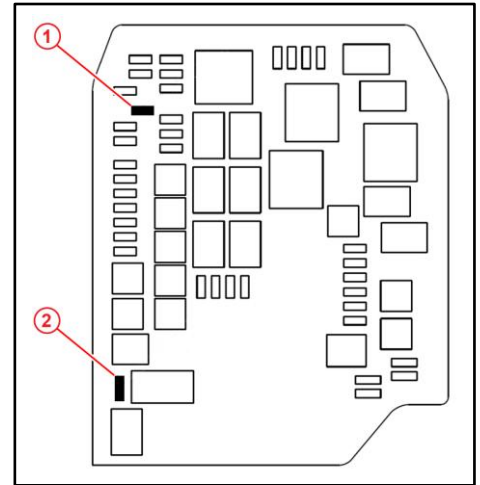

- 1 Install D/C CUT Fuse (30A) Here (Original Location)
- 2 Remove This D/C Cut Fuse (30A)

## TIRE PRESSURE WARNING SYSTEM (TPWS) INITIALIZATION

Refer to the Repair Manual for the [Initialization procedure](#). Please note the spare tire does NOT have a TPWS sensor.

### NOTE

To adjust the tire pressure correctly when the outside temperature is significantly colder than shop temperature, perform a Health Check using Techstream and select the "Compensation Tire Pressure" checkbox. Compensation pressures will be displayed on the Health Check results screen. Adjust the tire pressure when the tires are cold.

## COMPASS CALIBRATION

Refer to the Repair Manual for the [Calibration procedure](#) for vehicles equipped with a compass in the rear view mirror.

### NOTE

- Do NOT perform calibration of the compass in a place where the Earth's magnetic field is subject to interference (underground parking, under a steel tower, between buildings, roof parking, near a railroad crossing, near a large vehicle, etc.).
- During calibration, do NOT operate electric systems (moon roof, power windows, etc.) as they may interfere with the calibration.

## FRONT LICENSE PLATE & MOUNTING BRACKET\* INSTALLATION

1. Insert the front license plate into the tabs on the bracket.
2. Attach the clip of bracket to the upper lip of second air intake and rotate bracket upwards.
3. Align the holes on the license plate and license plate bracket with the dimples on the lower grille.
4. Screw the 2 self-tapping screws directly into the dimples to install the front license plate and the front license plate bracket.

### NOTICE

- Do NOT pre-drill holes into the bumper.
- Do NOT overtighten the self-tapping screws.

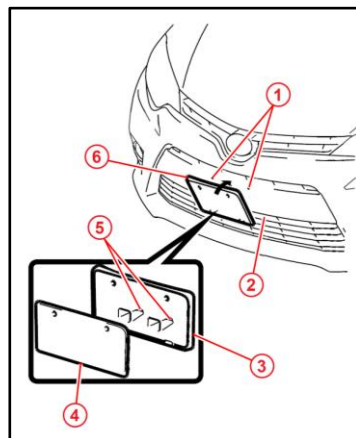

- 1 Dimples
- 2 Second Air Intake
- 3 Front License Plate Bracket
- 4 License Plate
- 5 Clip
- 6 Rotate Bracket

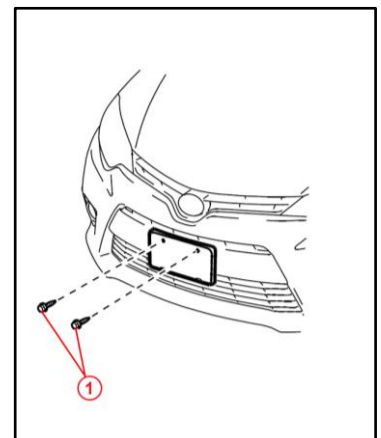

- 1 Self-tapping Screw