

D/C Cut Fuse Installation During PDS

Service Category General

Section Pre-Delivery Service

Market USA

Lexus Supports
ASE Certification 

Applicability

YEAR(S)	MODEL(S)	ADDITIONAL INFORMATION
2017	RX350, RX450H	

Introduction

To minimize battery discharge during transportation and storage, the D/C Cut Fuse (10A) has been removed at the assembly plant and temporarily stored in the engine compartment Relay Block. Reinstall the D/C Cut Fuse (10A) into its original location and clear ALL related Diagnostic Trouble Codes (DTCs) during Pre-Delivery Service (PDS).

Warranty Information

OP CODE	DESCRIPTION	TIME	OFF	T1	T2
N/A	Not Applicable to Warranty	–	–	–	–

D/C Cut Fuse Installation During PDS

Installation Procedure

Remove the D/C Cut Fuse (10A) from the blank space of the Relay Block in the engine compartment and install as shown in Figure 1.

Figure 1.

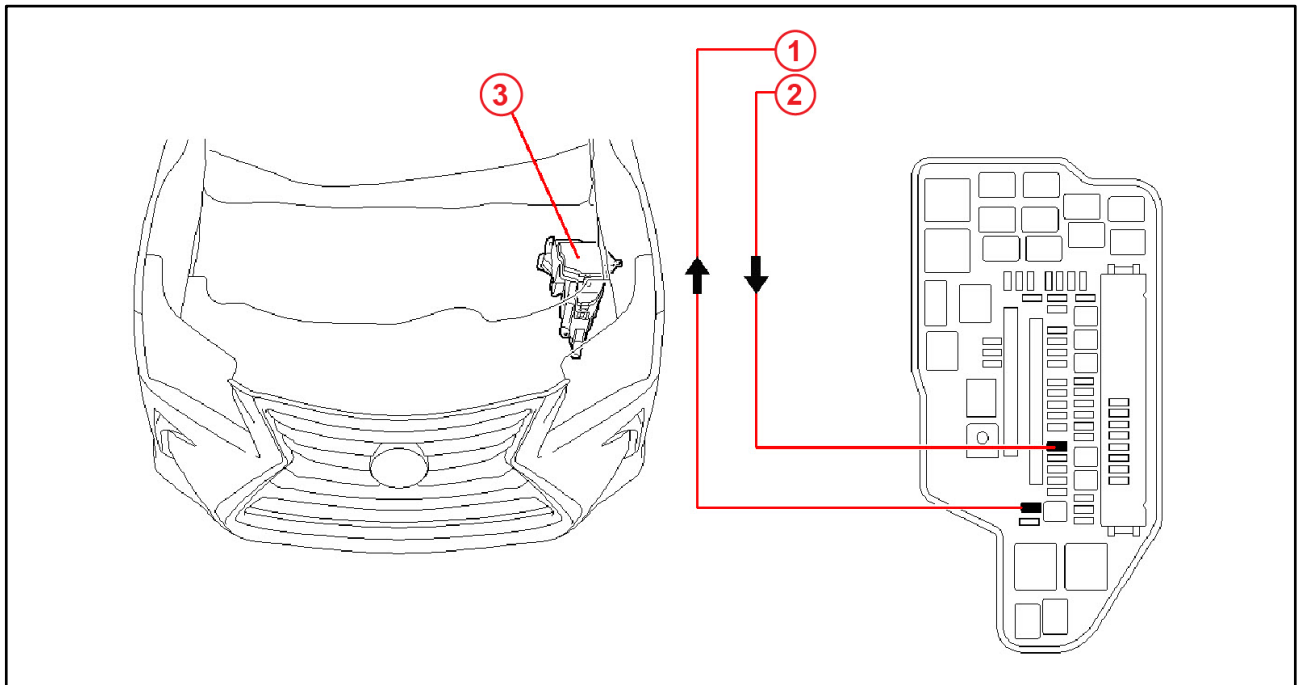

1	Remove This D/C Cut Fuse (10A)
2	Install D/C Cut Fuse (10A) Here (Original Location)

3	Relay Block
----------	-------------

NOTE

While the vehicle is stored at the dealership, disconnect the negative (-) battery terminal to prevent battery discharge. Refer to Service Bulletin No. [L-SB-0023-16](#), "Battery Maintenance During PDS," for battery maintenance information.