

# D/C Cut Fuse Installation During PDS

**Service Category** General

**Section** Pre-Delivery Service

**Market** USA

Lexus Supports  
ASE Certification 

## Applicability

YEAR(S)	MODEL(S)	ADDITIONAL INFORMATION
2017	GS200T, GS350, GS450H	

## Introduction

To minimize battery discharge during transportation and storage, the D/C Cut Fuse (30A) has been removed at the assembly plant and temporarily stored in the engine compartment Relay Block.

Reinstall the D/C Cut Fuse (30A) into its original location and clear ALL related Diagnostic Trouble Codes (DTCs) during Pre-Delivery Service (PDS).

## D/C Cut Fuse Installation During PDS

### Installation Procedure

Remove the D/C Cut Fuse (30A) from the blank space of the Relay Block in the engine compartment and install the D/C Cut Fuse (30A). Please note that hybrid and conventional gasoline vehicles have different Relay Block/fuse locations.

**Figure 1. Hybrid Models**

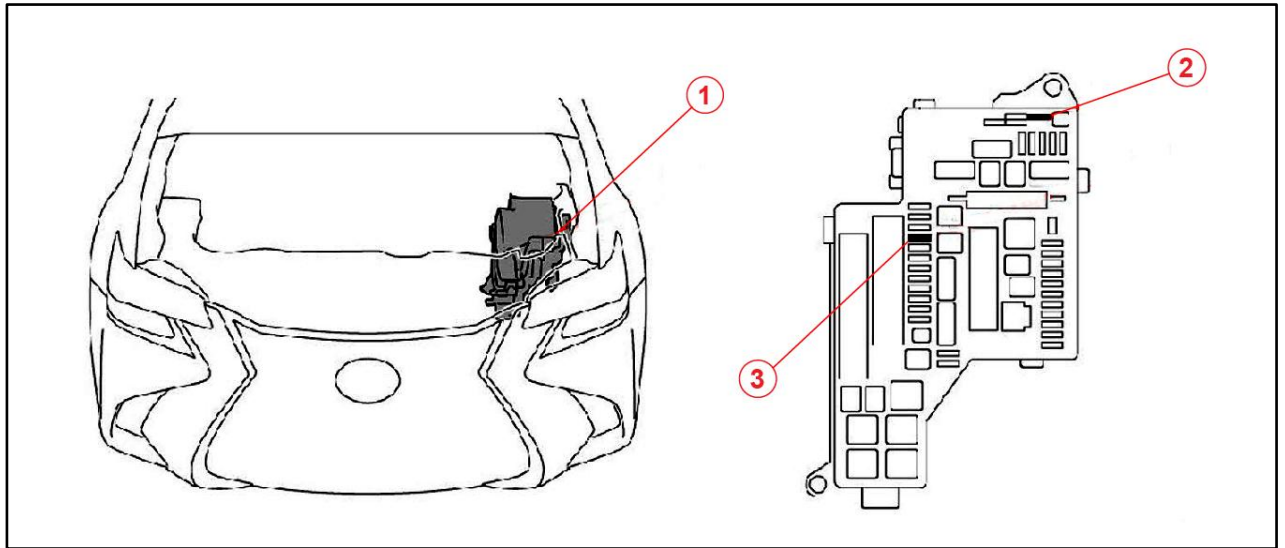

1	Relay Block
2	Remove This D/C Cut (30A) Fuse

3	Install D/C Cut Fuse (30A) Here (Original Location)
---	---

## D/C Cut Fuse Installation During PDS

### Installation Procedure (Continued)

**Figure 2. Gasoline Models**

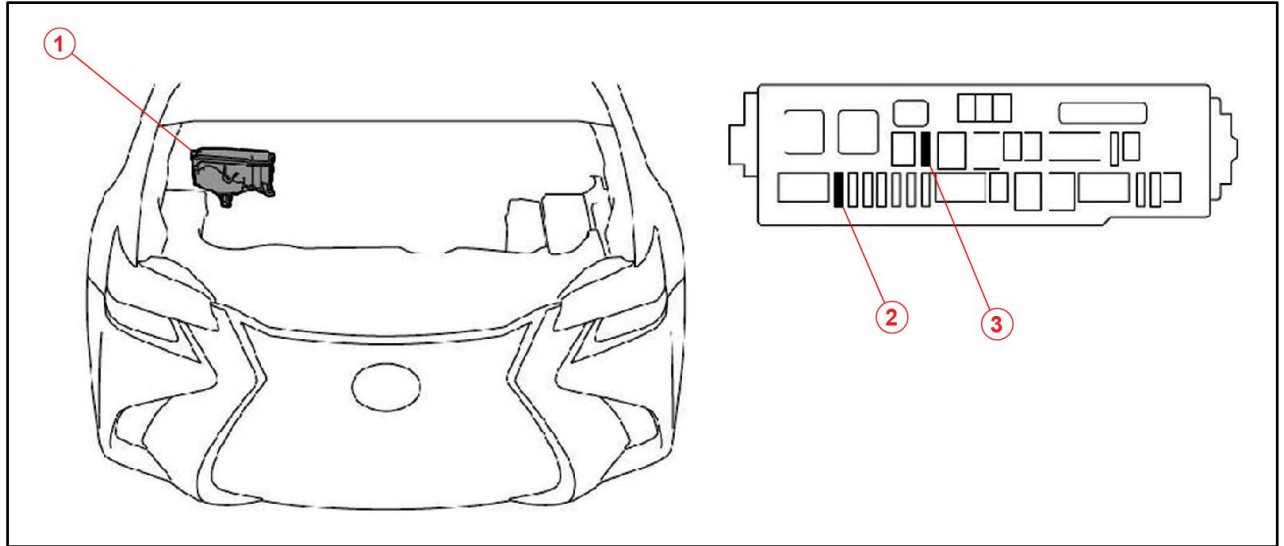

1	Relay Block
2	Install D/C Cut Fuse (30A) Here (Original Location)

3	Remove This D/C Cut (30A) Fuse
---	--------------------------------

#### **NOTE**

While the vehicle is stored at the dealership, disconnect the negative (-) battery terminal to prevent battery discharge. Refer to Service Bulletin No. [L-SB-0023-16](#), "Battery Maintenance During PDS," for battery maintenance information.