

ATTENTION:
 GENERAL MANAGER
 PARTS MANAGER
 CLAIMS PERSONNEL
 SERVICE MANAGER

IMPORTANT - All Service Personnel Should Read and Initial in the boxes provided, right.

© 2016 Subaru of America, Inc. All rights reserved.



QUALITY DRIVEN® SERVICE

SERVICE INFORMATION BULLETIN

APPLICABILITY: All 2017 MY Vehicles Equipped with EyeSight® and High Beam Assist (HBA) Features

NUMBER: 01-174-16
DATE: 07/21/16

SUBJECT: Windshield Sticker Placement Guideline

INTRODUCTION:

This Service Information bulletin provides a guideline to use for placement of required or mandated windshield stickers (inside and / or outside) on vehicles equipped with EyeSight Driver Assist Technology and High Beam Assist (HBA) features. Examples of these types of stickers include:

- Government facility / Military base access stickers
- State-mandated Vehicle Safety Inspection and Emission Compliance stickers
- Parking Permit Stickers

The cameras used by both of these features require a clear, unobstructed “view” through the windshield for their proper operation. The illustration below shows the “Prohibited area” in gray. Any stickers mandated to be placed within the Prohibited area should be placed to the right of the EyeSight stereo camera and HBA camera, outside of the Prohibited area as shown in the illustration below. Viewed from inside the vehicle, the left edge of the sticker must be placed no more than 14 inches (slightly less is preferred as a “cushion” for measuring variation) from the right edge of the windshield as shown in the illustration and indicated by the box outlined in blue. Always consult state and local regulations applicable to windshield sticker placement.

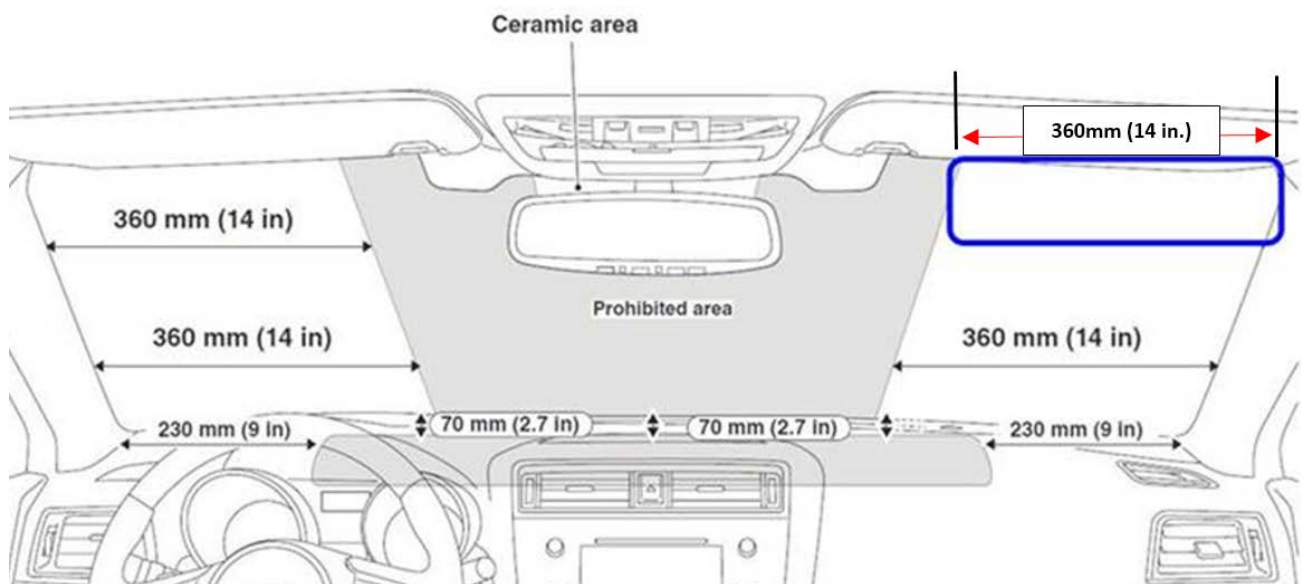

Continued...

IMPORTANT REMINDERS:

- SOA strongly discourages the printing and/or local storage of service information as previously released information and electronic publications may be updated at any time.
- Always check for any open recalls or campaigns anytime a vehicle is in for servicing.
- Always refer to STIS for the latest service information before performing any repairs.

CAUTION: VEHICLE SERVICING PERFORMED BY UNTRAINED PERSONS COULD RESULT IN SERIOUS INJURY TO THOSE PERSONS OR TO OTHERS.

Subaru Service Bulletins are intended for use by professional technicians ONLY. They are written to inform those technicians of conditions that may occur in some vehicles, or to provide information that could assist in the proper servicing of the vehicle. Properly trained technicians have the equipment, tools, safety instructions, and know-how to do the job correctly and safely. If a condition is described, DO NOT assume that this Service Bulletin applies to your vehicle, or that your vehicle will have that condition.

SUBARU OF AMERICA, INC. IS ISO 14001 COMPLIANT

ISO 14001 is the international standard for excellence in Environmental Management Systems. Please recycle or dispose of automotive products in a manner that is friendly to our environment and in accordance with all local, state and federal laws and regulations.