



INSTRUCTION TO SERVICE

ITS: 6182	
SECTION:	526 Seating and Stanchions
WRITTEN BY:	Troy Stutsky
SUBJECT:	Remove driver's barrier bottom hinge bolt and add Loctite and re-torque

ITS6182

THIS DOCUMENT AND THE CONTENTS DISCUSSED HEREIN ARE THE CONFIDENTIAL AND PROPRIETARY INFORMATION OF NEW FLYER INDUSTRIES CANADA ULC AND NEW FLYER OF AMERICA INC. AND ARE DISCLOSED BY NEW FLYER IN CONFIDENCE. THIS DOCUMENT AND THE CONTENTS HEREIN ARE NOT TO BE DISCLOSED BY THE INTENDED RECIPIENT WITHOUT THE PRIOR WRITTEN AUTHORIZATION OF NEW FLYER. ANY UNAUTHOIZED DISCLOSURE, REPRODUCTION OR OTHER DISTRIBUTION OF THIS DOCUMENT OR INFORMATION IS STRICTLY PROHIBITED AND MAY RESULT IN ACTION BEING TAKEN AGAINST THE PARTY MAKING THE UNAUTHORIZED DISCLOSURE. THIS DOCUMENT AND ALL COPIES HEREOF MUST BE RETURNED TO NEW FLYER UPON REQUEST.

PROCEDURE:

1. Turn the main battery disconnect switch to the “OFF” position.
2. At the bottom of the driver’s barrier door, check to see if the bolt that the door hinges on is loose See Figure 1. Record the finding on the inspection sheet found in Appendix A.
3. Remove the bolt that the door hinges on. See Figure 1.

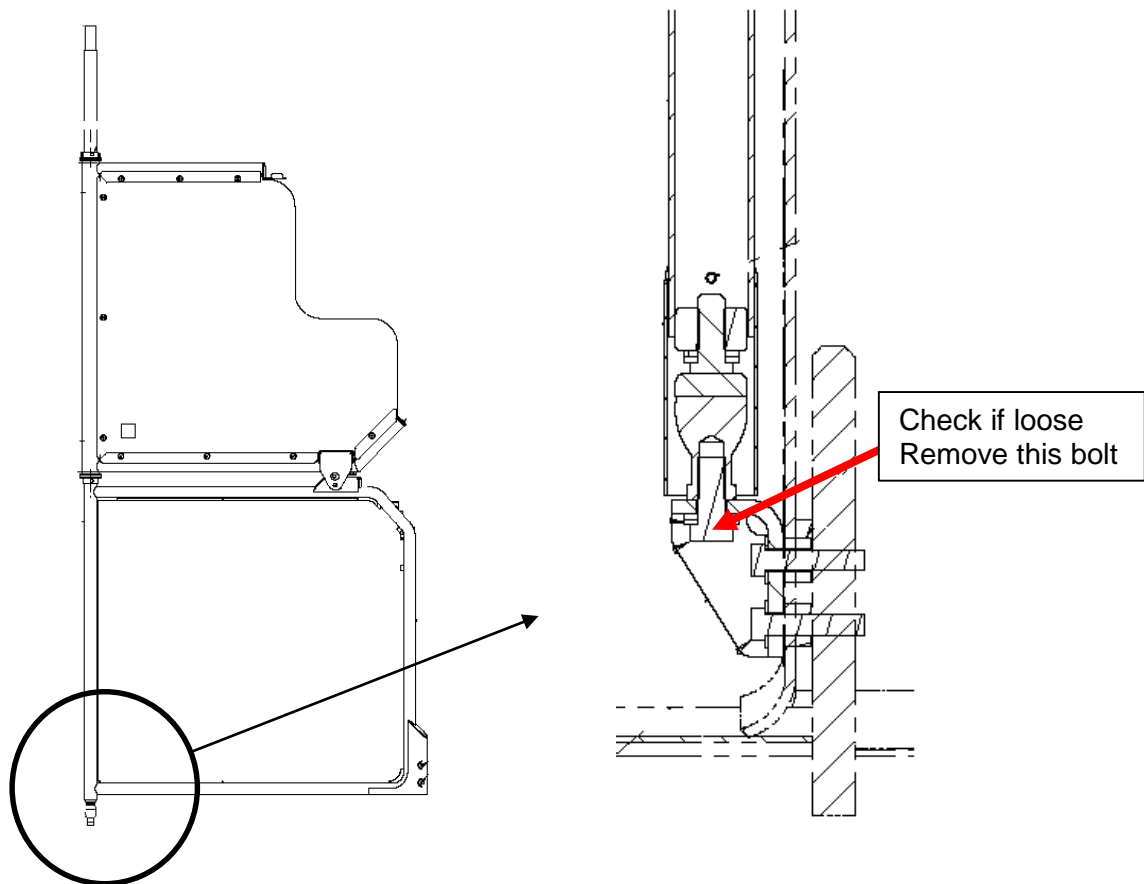

Figure 1: Affected bolt location

4. Inspect the bolt to see if Loctite has been applied and record on the inspection sheet found in Appendix A.
5. Re-apply 1-2 drops of Loctite 243 (NF PN 081034) to the threads of the bolt and re-torque the bolt to 14.5 – 16.5 Ft/Lbs.
6. Clean up all tools and debris and return the bus to service condition.
7. Turn the main battery disconnect switch to the “ON” position.
8. Please hand in all inspection sheets to your New Flyer RPSM - Regional Product Support Manager. If more inspection sheets are required, please copy the one in Appendix A.



NEW FLYER

LABOUR ESTIMATE

	Operation	Men	Hours	Labour Time M X HR
1	Remove driver's barrier bottom hinge bolt and add Loctite and re-torque	1	0.5	0.5

PARTS REQUIRED

Item	Part Number	Description	Qty. per Coach	Units	Notes
1	081034	LOCTITE-243 MEDIUM 10ML	0.01	EA	Source Locally