

# SAFETY RECALL

VOLVO Trucks North America  
Greensboro, NC USA

**VOLVO**

Date	Number	Release	Page
04.2016	<b>RVXX1603</b>	<b>01</b>	1 (4)

## One Piece Steering Shaft, Replacement

VN

### SAFETY RECALL INFORMATION

VOLVO Trucks North America has determined that a defect that relates to motor vehicle safety exists in certain VN 2016 and 2017 model vehicles manufactured from May 11, 2015 to March 8, 2016. The bolt connecting the upper steering shaft to the lower steering shaft at the junction block may not properly secure the upper steering shaft. Also the roll pin that secures that the lower shaft may have not been installed. **As a result, the upper steering shaft may separate without warning with complete loss of steering which may result in a vehicle crash.**

### VEHICLES AFFECTED

Certain 2016 and 2017 VOLVO VNL, VNM and VNX model vehicles built from May 11, 2015 through March 8, 2016 with a 2-piece steering shaft.

### VEHICLE QUANTITY

The number of vehicles affected is approximately 21,230 total (18,119 U.S., 3102 Canada, 9 Mexico).

### REQUIRED PARTS

Replace 2-piece steering shaft with single piece steering shaft.

**NOTE:** Greasable and non-greaseable steering shafts are equivalent replacement parts.

#### VNL, VNX

- 20785692, Greaseable Steering Shaft or 82394700, Non-Greasable Steering Shaft (1)
- 20924949, Bolt, M10\*45 (2)
- 984396, Nut, M10 (2)
- 3176476, Clip (2)
- 20549162, Boot (1)
- 948211, Tie Wrap (2)

#### VNM

- 20785689, Greaseable Steering Shaft or 82394702, Non-Greaseable Steering Shaft (1)
- 20924949, Bolt, M10\*45 (2)
- 984396, Nut, M10 (2)
- 3176476, Clip (2)
- 20549162, Boot (1)
- 948211, Tie Wrap (2)

If the vehicle is eligible, please call (877) 447-2787 with the Vehicle Identification Number (VIN) of the vehicle in need of repair.

## REPAIR PROCEDURE



Do not attempt to repair or service this vehicle without having sufficient training, the correct service literature and the proper tools. Failure to follow this could make the vehicle unsafe and lead to serious personal injury or death.

Failure to perform installation correctly can result in loss of steering which could result in serious personal injury or death.

**CAUTION: Possible equipment damage. The orientation of the contact reel to the center position of the steering gear must be maintained at all times. The steering wheel must be held in the center position anytime the steering column and the steering gear are not connected by the steering shaft. Failure to maintain proper contact reel orientation could result in breakage of the ribbon harness, rendering the SRS inoperable. Use of a cable tie to secure the steering wheel to the grab handle will assist in keeping the contact reel centered.**

1. Verify service recall eligibility by checking service recall status in VDA.
2. Secure the vehicle for service by parking it on a flat level surface, applying the parking brake, chocking the rear wheels, and placing the transmission in neutral. Open hood.
3. Ensure the vehicle front wheels are pointing straight ahead.
4. Remove the push clips from the bottom of the front and rear upper steering column covers.

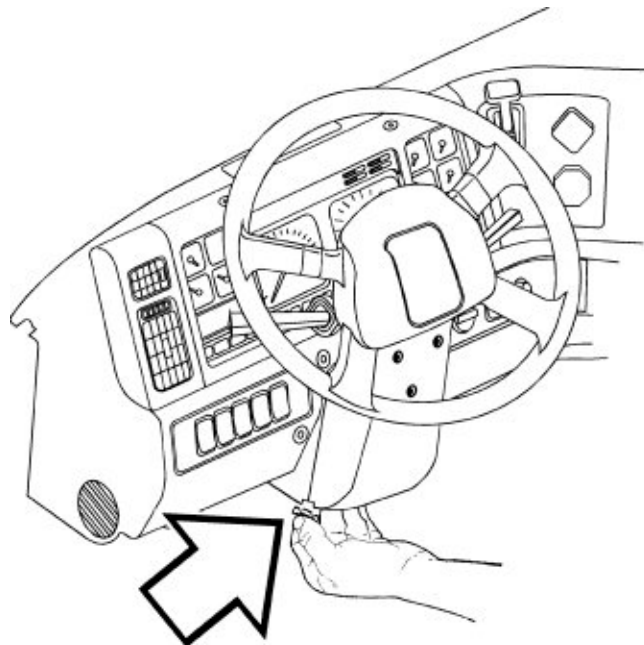

5. Remove the covers from around the steering wheel in the order shown.

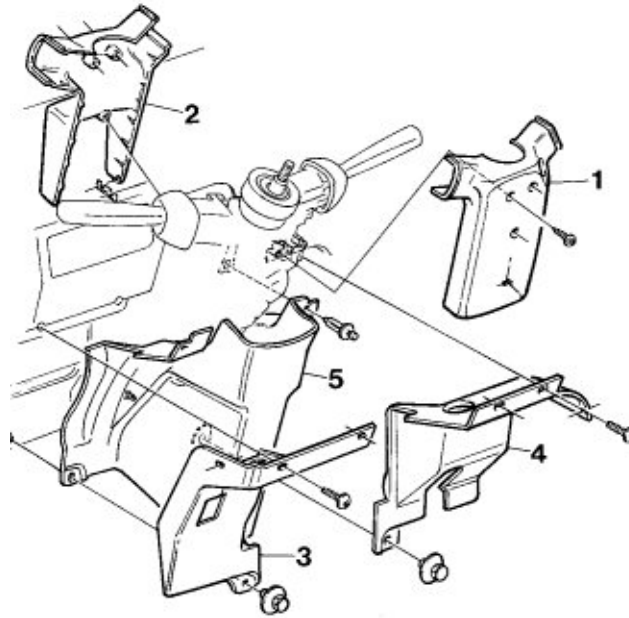

6. Loosen the pinch bolt on the steering shaft upper U-joint. Pry the U-joint off the steering column.
7. Remove the bolts from the shaft boot in the engine compartment. Retain the bolts for reuse.
8. Remove the pinch bolt on the steering shaft lower U-joint. Pry the U-joint off the steering gear.

**CAUTION: Possible equipment damage. Some steering gears have a plastic ring on the input shaft that acts as both a timing ring and a dirt cover. Use care not to damage the ring when prying the U-joint off the steering gear. Failure to use care could damage the plastic ring.**

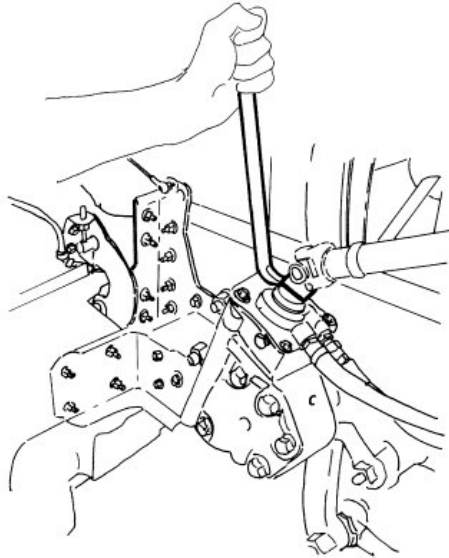

9. Pull the shaft and boot out of the cab from the engine compartment side.
10. Install the new shaft and new boot in from the engine compartment side

**NOTE:** See top image for VNL and bottom image for VNM.

**NOTE:** The greaseable steering shaft (black in color) is shown below. The non-greaseable steering shaft (silver in color) is not shown.



11. Replace the pinch bolts on each end of the steering shaft with a new original equipment bolt.
12. Connect the shaft upper U-joint to the steering column. Tighten the pinch bolt to  $60 \pm 10$  Nm ( $45 \pm 7$  ft-lb). The pinch bolt is perpendicular to the steering column shaft.
13. Ensure the steering wheel is centered.
14. Connect the shaft lower U-joint to the steering gear input shaft. Tighten the pinch bolt to  $60 \pm 10$  Nm ( $45 \pm 7$  ft-lb).

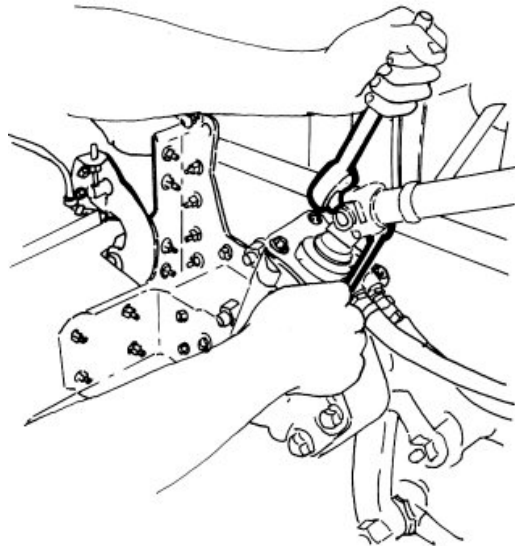

15. Perform a final alignment of the lower steering shaft. Correct any tightness in the steering mechanism.
16. Install and tighten the bolts in the steering shaft boot.
17. Install the steering column covers in the reverse order from removal and tighten the torx screws.
18. Install the push clips on the front and rear upper steering column covers.
19. If equipped with ESP, use Bendix® ACom™ to calibrate the steering angle sensor.
20. Test-drive the vehicle. Check and align the steering wheel position.

**REIMBURSEMENT**

<b>This repair is covered by an authorized Safety Recall campaign. Reimbursement is obtained through the normal claim handling process.</b>	
	<b>UCHP Reimbursement</b>
<b>Claim Type</b> (used only when uploading from the Dealer Business System)	R
<b>Recall Status</b>	
<b>Vehicle repaired per instructions</b>	
<b>Primary Labor Code</b>	
<b>One Piece Steering Shaft, Replacement</b>	6412-03-09-05 0.5 hrs
<b>Optional Labor Codes</b>	
<b>Calibrate ESP</b>	5931-08-03-20 0.4 hrs
<b>Time to take charge of vehicle and determine campaign status</b>	1700-16-01-01 0.3 hrs
<b>Causal Part</b>	60111124
<b>Authorization Number</b>	C6568

**Note:** Take-charge time is not included in the labor code for this operation. Take charge may be eligible, but can only be used once per vehicle repair visit. If the vehicle is having other warranty repairs performed, take-charge should be charged to the warranty repair, otherwise take-charge can be charged to this Safety Recall campaign.

**Note:** Dealers are to perform Safety Recall Campaigns on all subject vehicles at no charge to the vehicle owner regardless of mileage, age of vehicle or ownership (original purchaser or subsequent purchasers). Whenever vehicles are subject to a safety recall are brought to your dealership for service, or taken into your dealership vehicle inventory, it is strongly recommended that every effort be made to perform the recall correction before the vehicle is sold or released to the owner.