

Tire Pressure Monitoring System (TPMS)  
Connector, Remove  
VN

## **FSB 776-002, Connector, Tire Pressure Monitoring System (TPMS), Remove**

(June 2016)

On some VOLVO VN trucks built from 11/10/2014 to 05/15/2016 and not equipped with Tire Pressure Monitoring System (TPMS), the front chassis harness is equipped with a TPMS connector sealed with a rubber cap. Over time, the rubber cap may allow water intrusion and lead to corrosion of the harness and the J1939 datalink circuits. Corrosion of the J1939 datalink circuits may lead to diagnostic trouble codes (DTCs) and loss of datalink communication between Electronic Control Units (ECUs). To resolve the issue of DTCs and loss of datalink communication between the ECUs, removal of the TPMS connector is required. Follow the repair instructions outlined in this Field Service Bulletin (FSB).

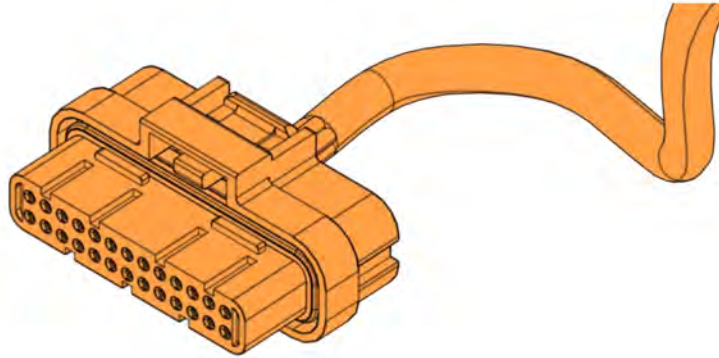

W7112723

## Required Parts Tire Pressure Monitoring System (TPMS) Connector, Remove

Item	Description	Part Number	Qty
1	Heat Shrink Tubing	8071826	5
2	Harness Repair Tape	20469544	1

## Decommissioning the Truck for Repair

You must read and understand the precautions and guidelines in Service Information, group 70, "General Safety Practices, Frame, Springs, Shocks & Wheels" before performing this procedure. If you are not properly trained and certified in this procedure, ask your supervisor for training before you perform it.

**NOTE:** Information is subject to change without notice. Illustrations are used for reference only and can differ slightly from the actual vehicle being serviced. However, key components addressed in this information are represented as accurately as possible.

- 1 Park the vehicle on a flat and level surface.
- 2 Apply the parking brake.
- 3 Place the transmission in neutral or park.
- 4 Install the wheel chocks on the front wheels.

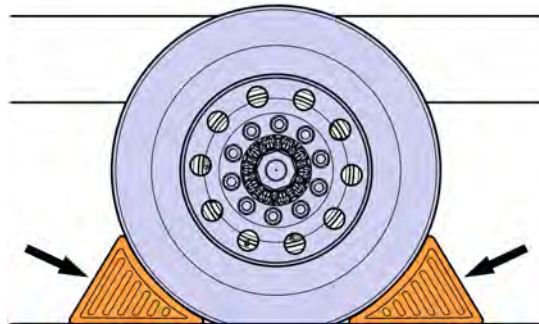

W7086748

- 5 Disconnect the cable from the battery's negative terminal.

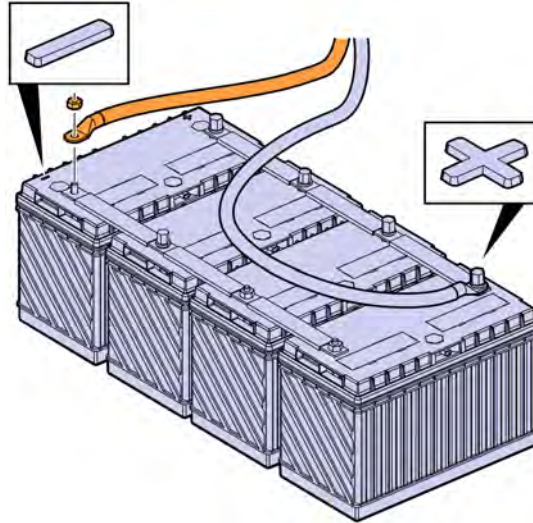

W3086747

## Rear Axle Seat, Replacement

- 1 If applicable, unlatch and tilt down the front right side fairing.
- 2 If applicable, remove the cable securing the front right side fairing.
- 3 Remove the front right side fairing.

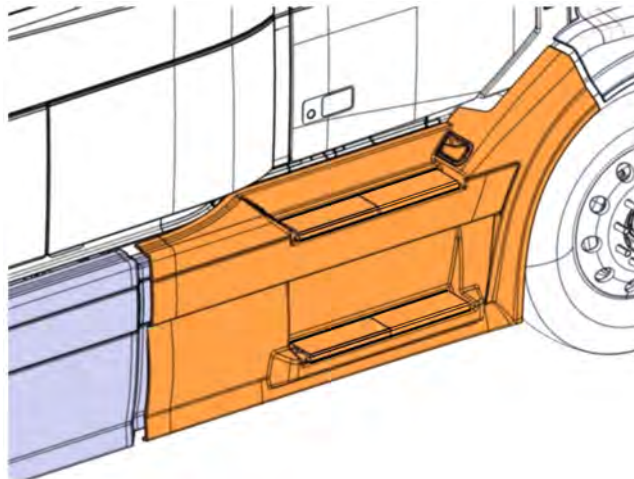

W7112726

- 4 If applicable, remove the rear right side fairing.

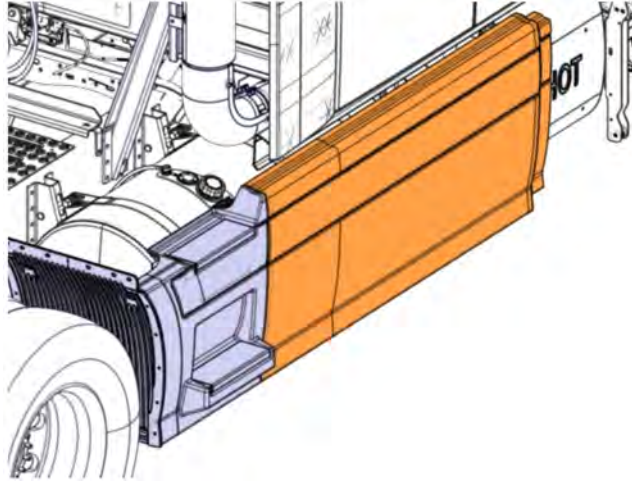

W7112727

- 5 Locate the TPMS connector on the cross member as shown.

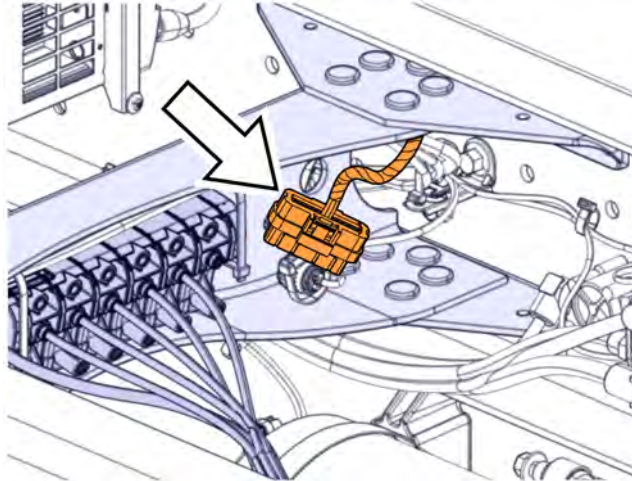

W7112728

- 6 Cut any cable ties securing the TPMS connector.
- 7 Cut the five wires at the TPMS connector as shown in the figure below.

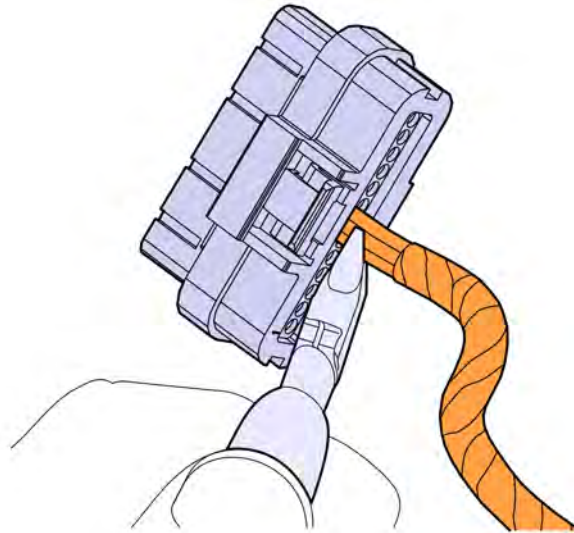

W7112729

- 8 Remove approximately 31.7 mm (1.25 in) of harness repair tape from the wires as shown in dimension (A).

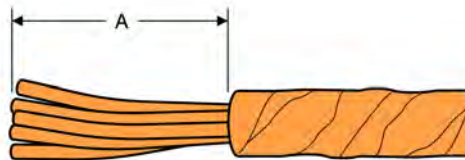

W7112730

- 9 Position one piece heat shrink tubing over of a wire, leaving approximately 3 mm (0.1 in) past the end of the wire as shown in dimension (B).

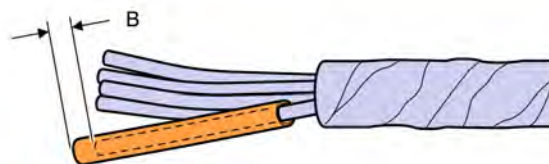

W7112731

10 Using a heat gun, heat shrink the tubing as shown.

**Note:** Heat shrink the tubing until glue is visible at the end of the tubing.

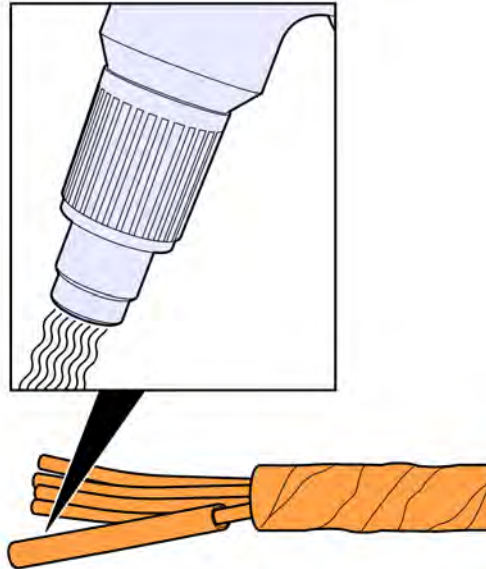

W7112732

11 Repeat steps 9 through 10 for the remaining wires.

12 Secure the five wires to the main harness with harness repair tape as needed.

13 Using cable ties secure the harness as needed.

14 If applicable, install the rear right side fairing.

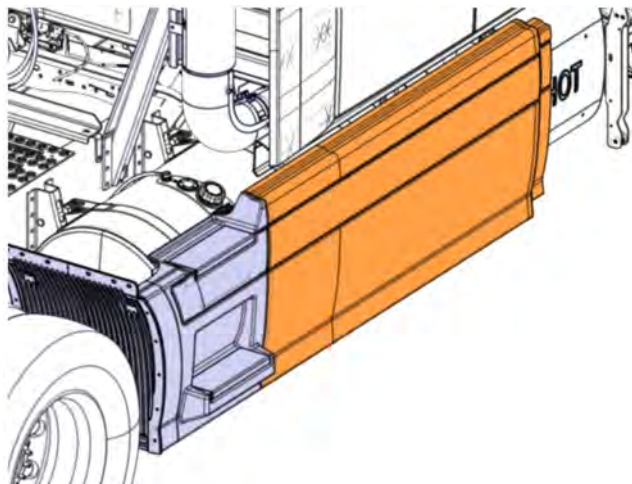

W7112727

- 15 If applicable, install the front right side fairing and connect the cable securing the fairing.
- 16 If applicable, close and latch the front right side fairing.

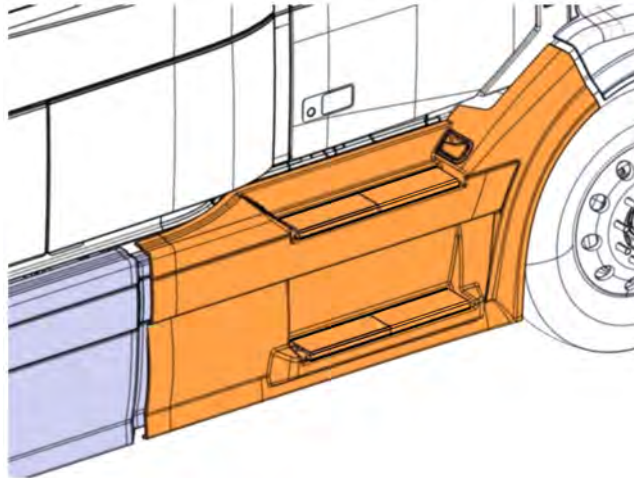

W7112726

## **Commissioning the Truck for Operation**

- 1 Connect the battery cable to the negative (ground) terminal.

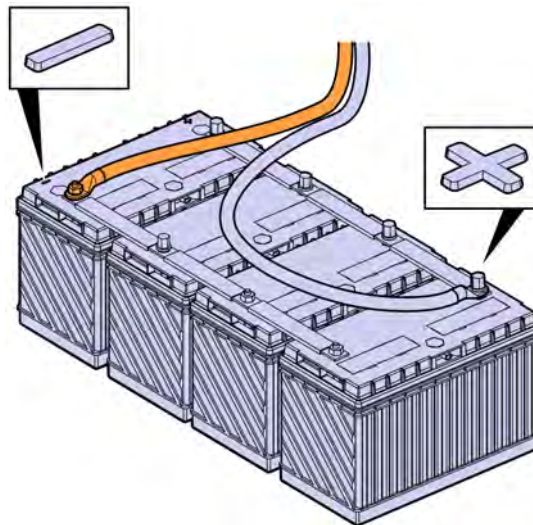

W3086758

2 Remove the wheel chocks.

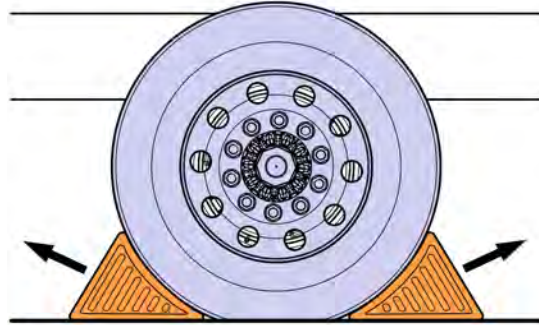

W7086759

**Reimbursement**

<p><b>This repair may be eligible for reimbursement if a product failure was experienced within time and mileage limits of the applicable Warranty coverage. Reimbursement is obtained via the normal claim handling process.</b></p>	<p><b>UCHP Reimbursement</b></p>
<p><b>Claim Type (used only when uploading from the Dealer Bus. Sys.)</b></p>	<p>W</p>
<p><b>Labor Code</b></p>	<p style="background-color: #cccccc;"></p>
<p>Primary Labor Code (Tire Pressure Monitoring System (TPMS) Connector, Remove)</p>	<p>7761-01-09-01              0.3 hrs.</p>
<p><b>Causal Part</b></p>	<p>22017633</p>

VOLVO Trucks North America reserves the right to make any changes in design or to make additions to or upon its products without incurring any obligations to install the same on vehicles previously built.