



SERVICE CAMPAIGN BULLETIN

Reference:

NTB16-097

Date:

October 12, 2016

VOLUNTARY EMISSIONS SERVICE CAMPAIGN 2016 TITAN XD WITH CUMMINS 5.0L; HIGH PRESSURE TURBOCHARGER

CAMPAIGN ID #: PC471

APPLIED VEHICLE: 2016 Titan HD (A61) with Cummins 5.0L

Check Service COMM to confirm campaign eligibility.

INTRODUCTION

Nissan is conducting a Voluntary Emissions Service Campaign on certain specific Model Year 2016 Nissan Titan XD vehicles with Cummins 5.0L to inspect and replace the high pressure turbocharger assembly. This service will be performed at no charge to owners for parts or labor.

IDENTIFICATION NUMBER

Nissan has assigned identification number PC471 to this campaign. The correct number must appear on all communications and documentation of any nature dealing with this campaign.

DEALER RESPONSIBILITY

Dealers are to correct each vehicle falling within the range of this campaign that enters the service department. This includes vehicles purchased from private parties or presented by transient (tourist) owners and vehicles in a dealer's inventory.

Nissan Bulletins are intended for use by qualified technicians, not 'do-it-yourselfers'. Qualified technicians are properly trained individuals who have the equipment, tools, safety instruction, and know-how to do a job properly and safely. **NOTE:** If you believe that a described condition may apply to a particular vehicle, DO NOT assume that it does. See your Nissan dealer to determine if this applies to your vehicle.

Required Special Tools

Special Tools – J-54423, J-54427, J-51951, and J-45695-A

J-54423: Air Handling System Clean Care Kit (see Figure A)

J-54427: Fuel System Clean Care Kit (see Figure B)

If needed – J-51951: Tech Cam (borescope – see Figure C)

J-45695-A: Coolant Refill Tool (see page 3, Figure D)

- These special tools have been previously sent to each dealer.
- Additional kits and components can be ordered from TECH•MATE at:
 - 1-800-662-2001
 - OR
 - nissantechmate.com



Figure A



Figure B

J-51951

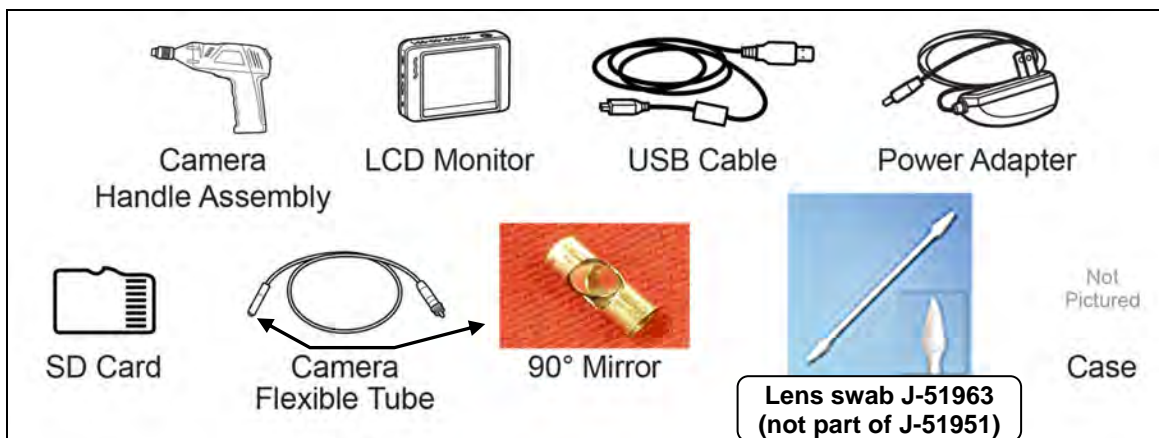

Figure C

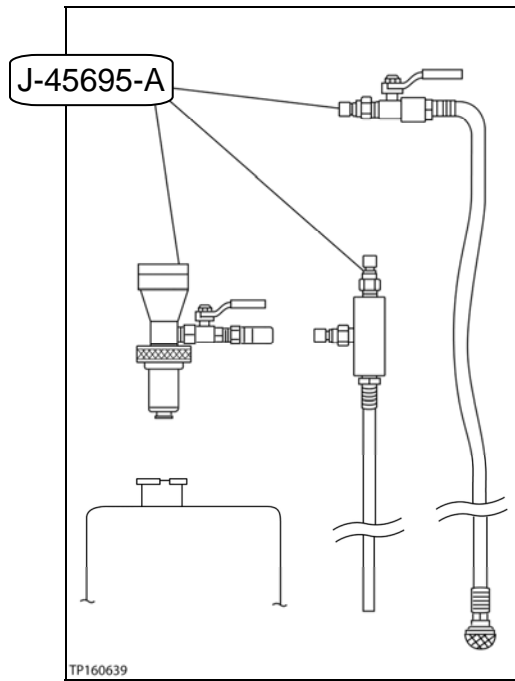
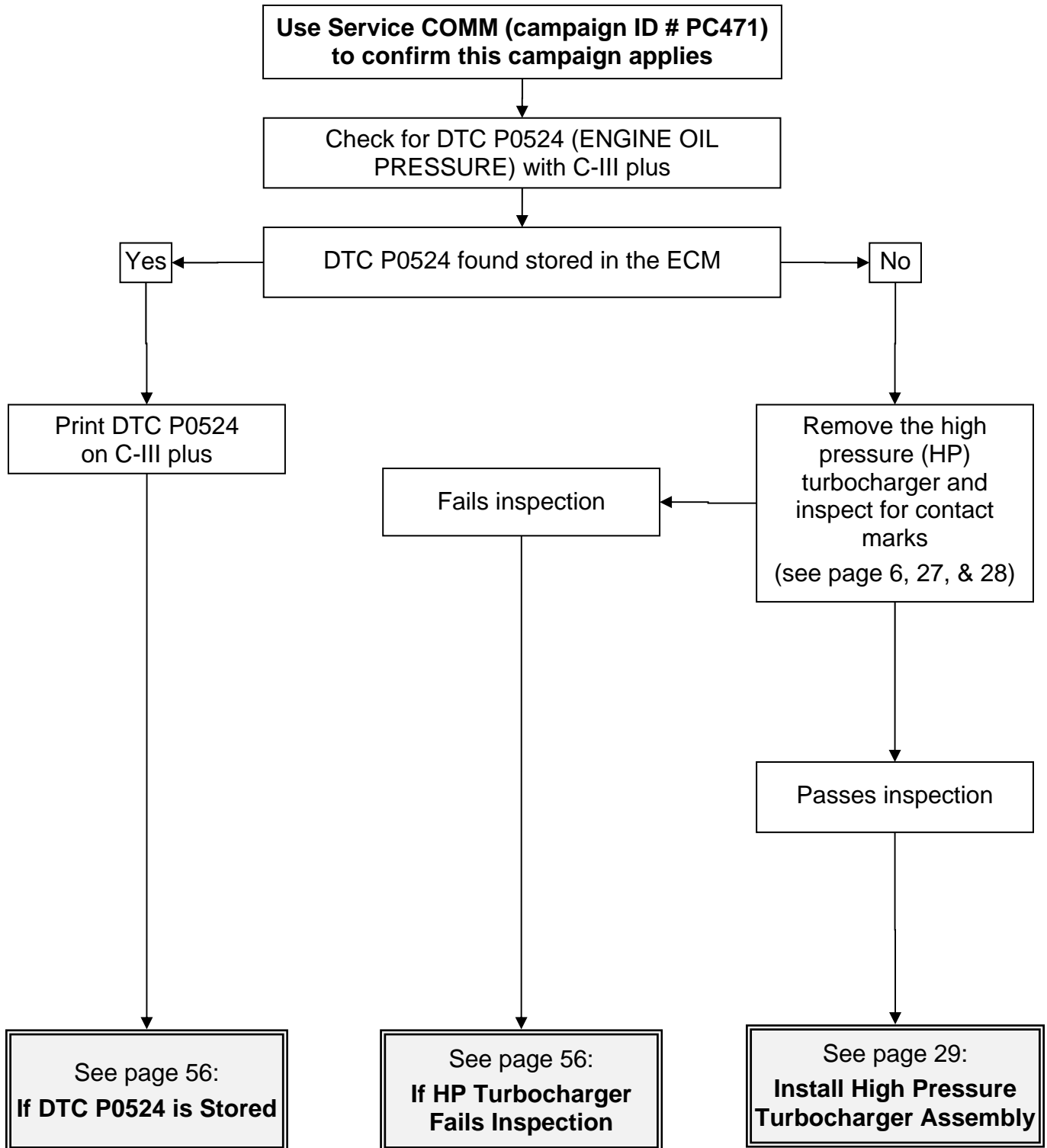

Figure D

REPAIR OVERVIEW



SERVICE PROCEDURE

Check for DTC P0524

1. Connect the plus VI to the vehicle.
2. Turn the ignition ON with the engine OFF.
3. Turn ON the CONSULT PC.
4. Select CONSULT-III plus (open C-III plus).
5. Wait for the plus VI to be recognized / connected.
6. Select **Diagnosis (All Systems)**, and then check for DTC P0524 (ENGINE OIL PRESSURE).

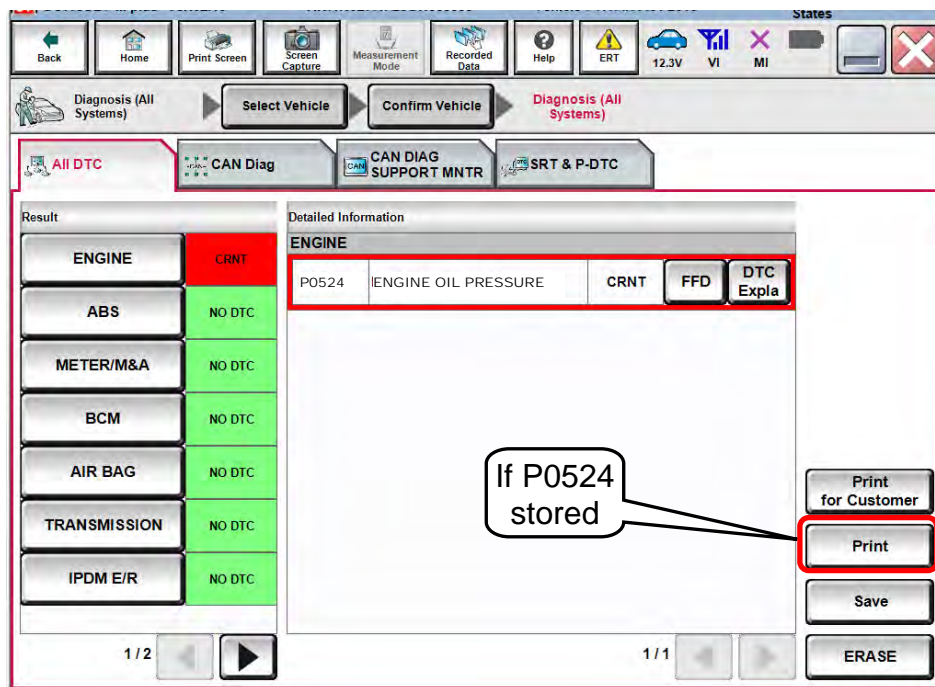

Figure 1

7. If DTC P0524 is not found stored, remove and inspect the high pressure turbocharger.
 - Go to the next page.
8. If DTC P0524 is found stored, STOP HERE. For further instructions, go to page 56, **If DTC P0524 is Stored.**

Remove and Inspect High Pressure Turbocharger Assembly

IMPORTANT: Follow all cautions, warnings, and notes in the Electronic Service Manual (ESM) when working on or near the fuel system, turbocharger system, and all parts and components related to the repair procedure in this bulletin.

CAUTION:

- Cover the surrounding areas of the engine bay with suitable protection to avoid damage to paint and all other surrounding exterior parts.
- When removing components such as hoses, tubes, fuel lines, etc., be sure to cap, plug, or tape these openings to prevent fluid from spilling or debris from entering.
 - Refer to special tools J-54423 and J-54427 for caps, plugs, and tape (see page 2).
 - The caps and plugs can be reused. Make sure to put them back in the kits when they are not needed.
 - When told to use tape, use the tape supplied in kit J-54423 only. When removed, this tape does not leave a residue. Tape residue may cause leaks.

1. Clean all loose dirt and debris from the engine bay area and wherever work is to be performed with 30 psi maximum compressed air.

WARNING: Wear appropriate eye protection and protective clothing. Failure to use protective wear and/or operating compressed air above 30 psi may increase the possibility of physical injury.

2. Record all audio presets.

Presets	1	2	3	4	5	6
AM						
FM 1						
FM 2						
SAT 1						
SAT 2/3						
Bass	Treble	Balance	Fade	Speed	Sen.	Vol.

3. Set the vehicle on a suitable lift, and then remove all tire and wheel assemblies.

NOTE: Removing the tire and wheel assemblies will allow the vehicle to be further lowered for easier access in the engine bay area.

4. Open the hood, and then place suitable covering protection over the fenders and all areas where leaning over and into the engine bay area.
5. Disconnect all battery cables, negative cables first.

6. Raise the vehicle, and then remove the front under cover (see Figure 2).

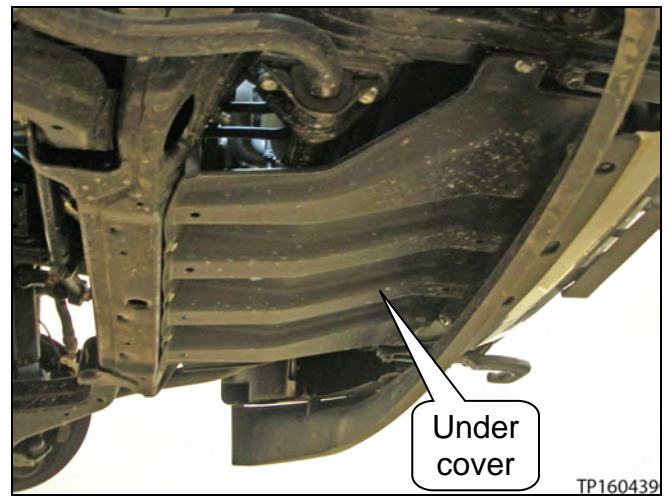

Figure 2

7. Drain the coolant from the radiator drain plug in a clean drain pan.

Tip: Reduce coolant spillage by first attaching a hose to the drain plug nipple.

- Remove the radiator cap and reservoir tank cap after opening the drain plug.
 - Reinstall both caps and tighten the drain plug once the coolant has finished draining.

NOTE: The coolant will be reused. Store the coolant in an area where it will not get contaminated.

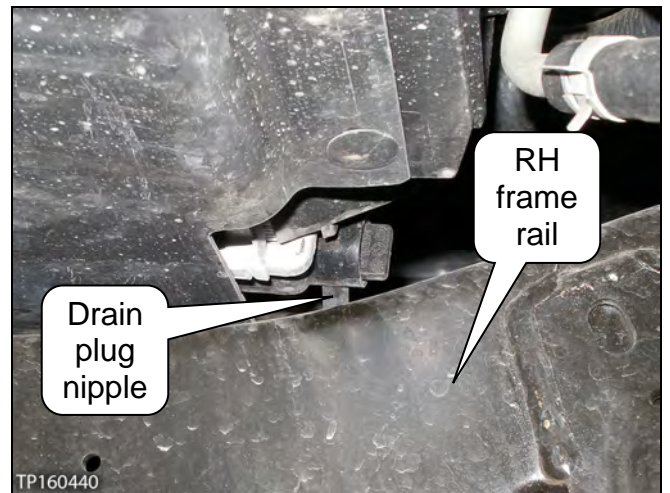

Figure 3

8. Disconnect the end of the reservoir tank coolant line shown in Figure 4.



Figure 4

9. Remove the cowl.

- a. Make sure the wiper arms are in the auto stop, or “parked”, position.
- b. Remove the wiper arm covers (see Figure 5).
- c. Remove the wiper arm nuts, and then remove the wiper arms.

- The wiper arms may need to be carefully rocked back and forth on their pivot shafts before coming loose.

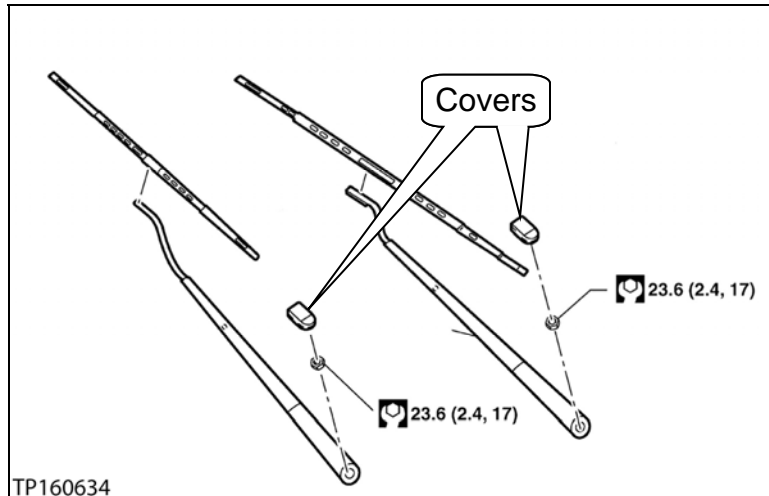

Figure 5

- d. Disconnect the washer nozzle supply hose (see Figure 6).

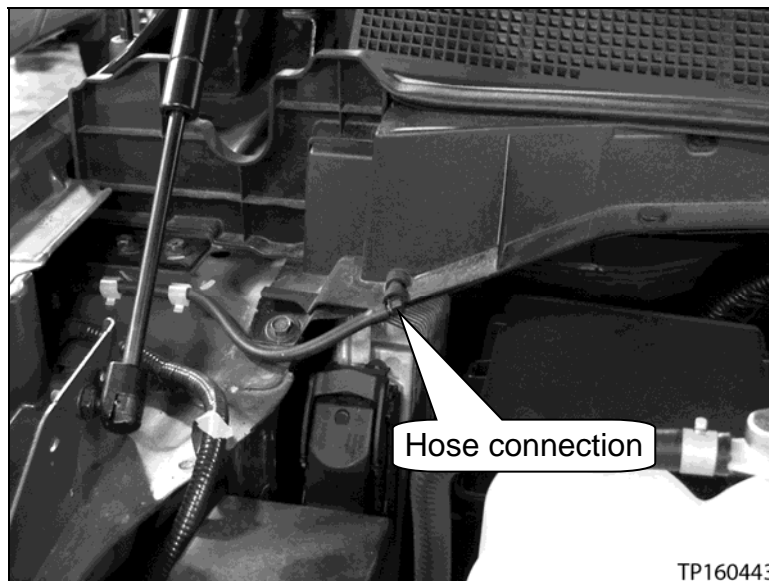

Figure 6

- e. Using a suitable tool, unsnap all pawls and clips, and then carefully remove the cowl top cover (see Figure 7, # 1).
- NOTE:** Remove the cowl top side trim cover(s) as needed (see Figure 7, # 2).
- f. Remove the cowl top extension bracket (see Figure 7, # 4).
 - g. Disconnect the electrical connector, remove the three (3) bolts, and then remove the wiper drive assembly (see Figure 8).
 - h. Remove the eight (8) bolts and both drain pipes, and then remove the cowl top extension (see Figure 7, # 3 & 5, and Figure 9 and 10).

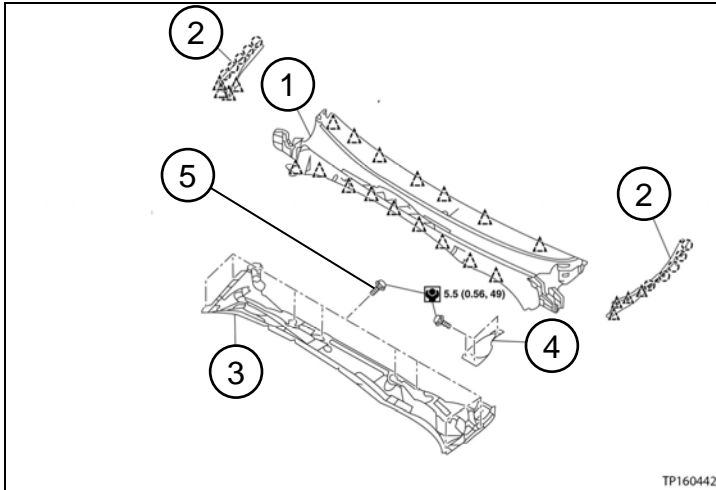

Figure 7

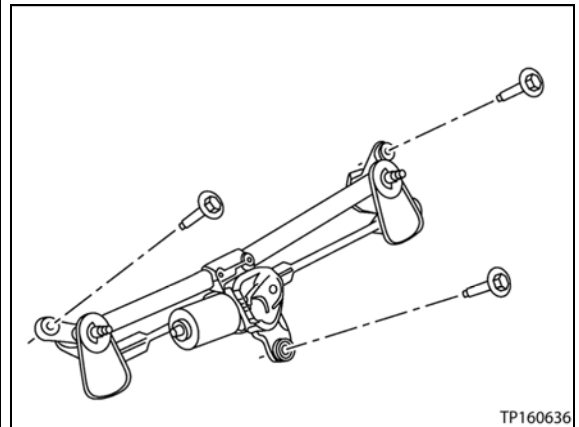

Figure 8

- | | | |
|-------------------------------|-------------------------------------|-----------------------|
| 1. Cowl top cover | 2. Cowl top side trim cover | 3. Cowl top extension |
| 4. Cowl top extension bracket | 5. Cowl top extension bracket bolts | |

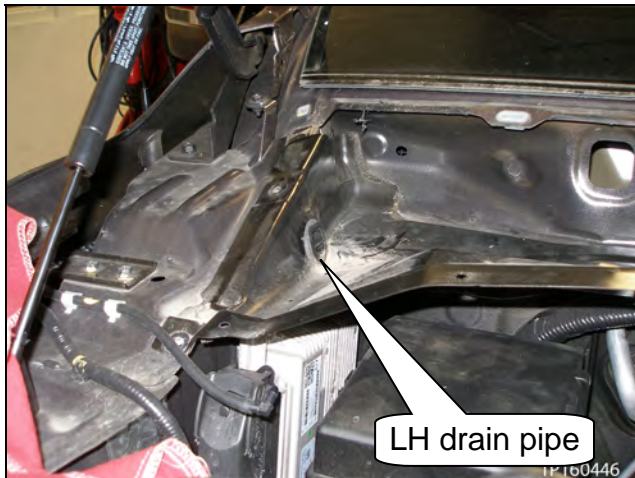

Figure 9

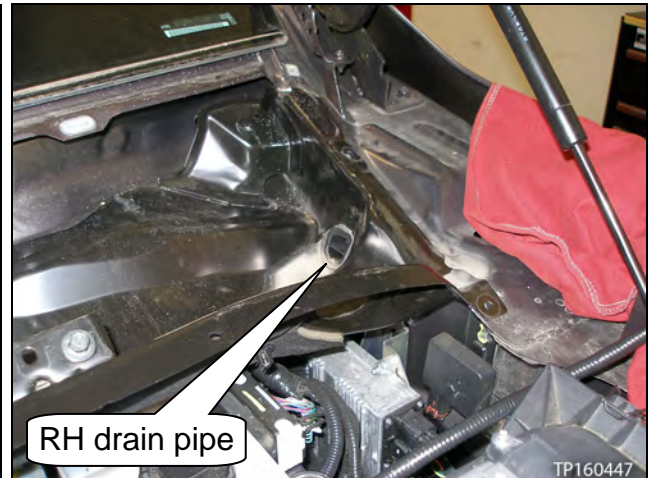

Figure 10

10. Remove the nine (9) bolts, and then remove all three heat shields (see Figure 11).

- The center heat shield needs to be removed first.
- The vehicle will need to be raised to access some of the bolts.

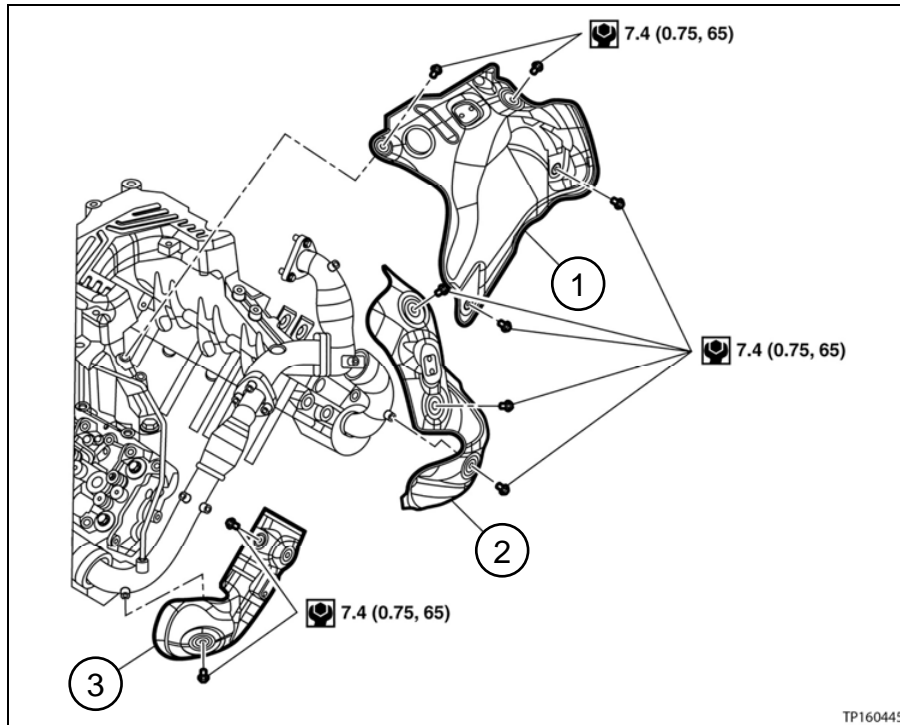

Figure 11

1. Center heat shield

2. RH heat shield

3. LH heat shield

11. Remove the air duct with upper air cleaner case (see Figure 12).

- The mass air flow sensor and turbocharger compressor intake pressure/temperature sensor will need to be disconnected.
- Make sure to cover the intake opening (see Figure 13).
- Place the air cleaner element where it will not be exposed to dirt or debris.

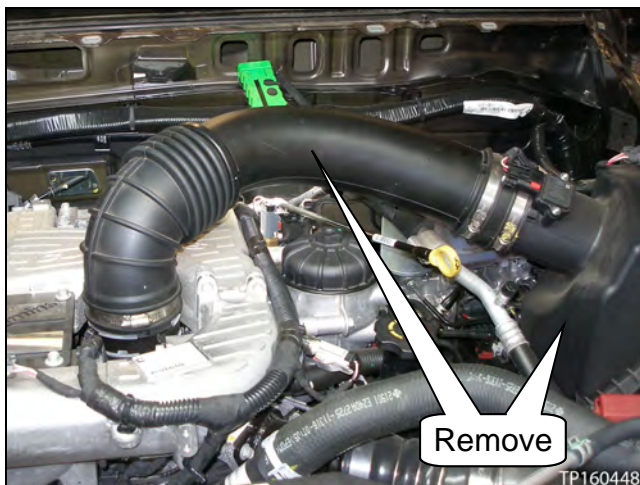

Figure 12



Figure 13

12. Disconnect the EGR valve actuator electrical connector (see Figure 14).
 13. Disconnect the engine control harness connectors, and then move the section of engine control harness out of the way (see Figure 14).
- Figures 15-17 show how to unfasten the different types of connectors.

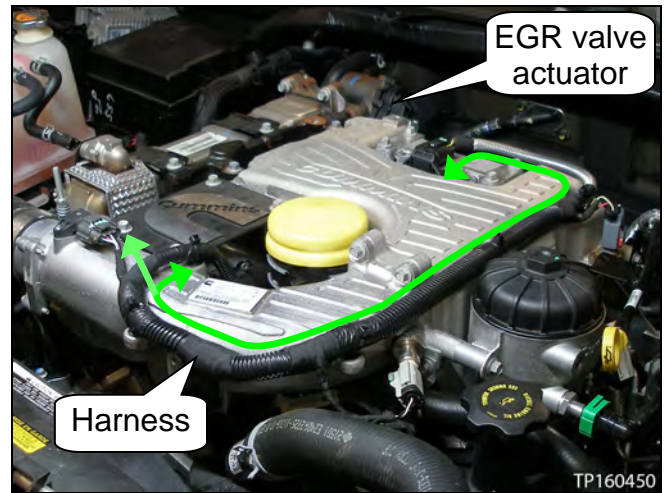

Figure 14

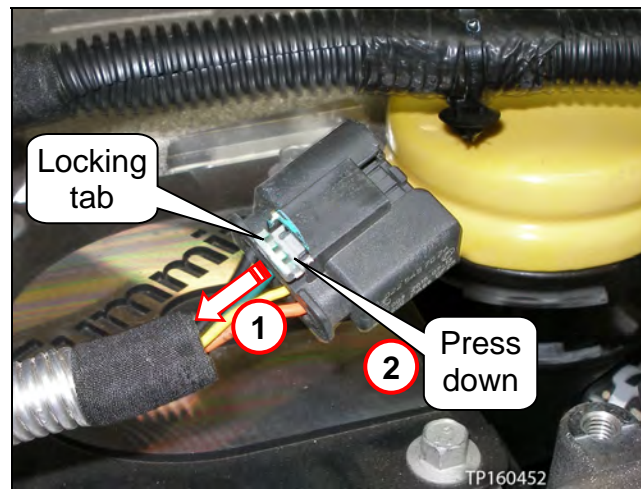

Figure 15

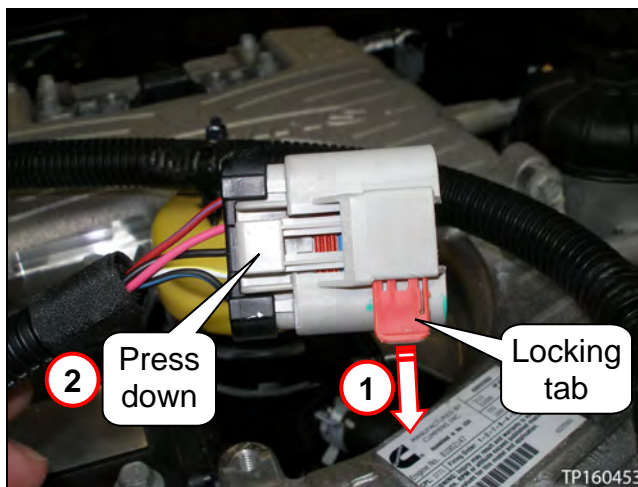

Figure 16



Figure 17

14. **Important:** Check the engine oil level **NOW**, record the results.

- It is important to check the oil level at this time. See **CAUTION** on page 42, step 38.

15. Carefully remove the oil dipstick with tube.

a. Remove the bolt where shown in Figure 18.

- Figure 18 is viewed by looking down behind the rear of the turbocharger assemblies.

Tip: Use a magnet with extension to keep from losing the bolt.

b. Unclip the fuel lines from their clips (see Figure 19).

c. Remove the four (4) bolts where shown in Figure 19.

d. Carefully remove the oil dipstick and tube.

- Make sure the O-ring seal is attached to the oil dipstick tube.

NOTE: The fuel line bracket stays bolted to the oil dipstick tube.

CAUTION: Be careful not to bend or kink the oil dipstick tube while removing.

e. Install a plug into the oil dipstick tube's engine block hole (see Figure 20).

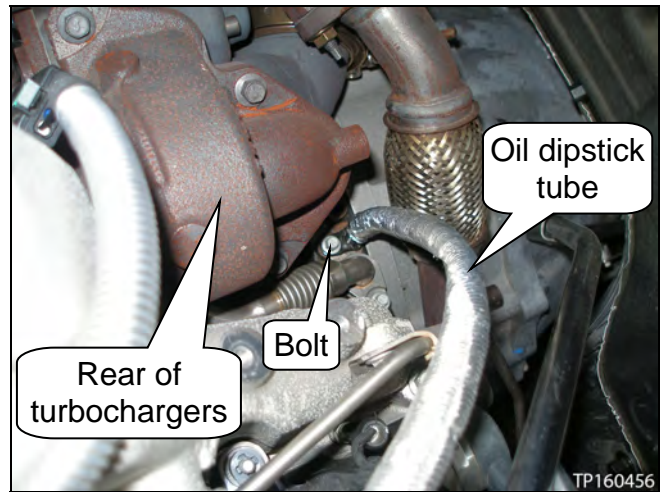

Figure 18

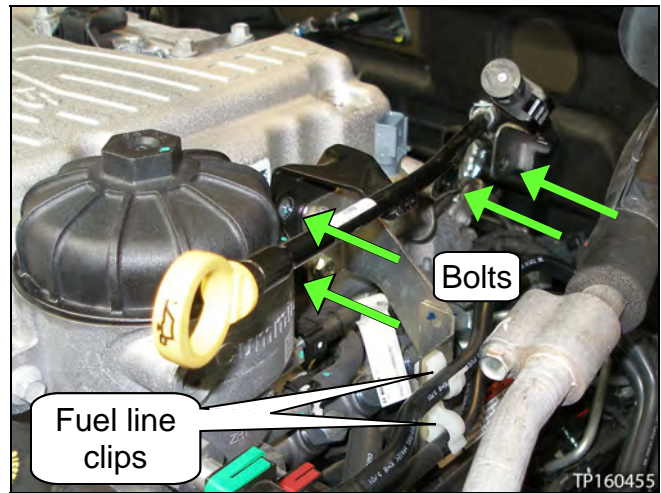

Figure 19

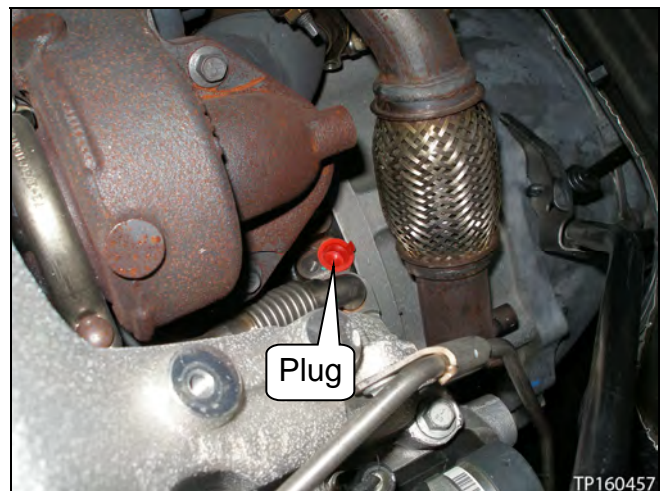

Figure 20

16. Unfasten the stage 2 fuel filter assembly from the intake manifold assembly.

a. Drain fuel from the primary fuel lines, stage 2 fuel filter assembly, and stage 1 fuel filter assembly.

- Open the drain valve and allow fuel to drain in a suitable container until the fuel slows down to a trickle (see Figure 21).
- Dispose of the drained fuel following local regulations.

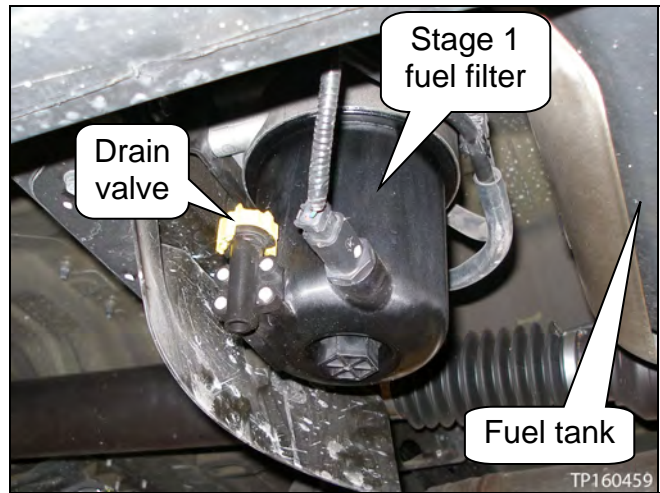

Figure 21

b. Place clean shop cloths under the stage 2 fuel filter assembly fuel line (see Figure 22).

NOTE: Although the fuel lines and fuel filter assemblies have been drained, some residual fuel may still drain out.

c. Disconnect the fuel line shown in Figure 22 and 23.

- To remove the fuel line, pinch the tabs on both sides of the fuel line connector, and then pull off (see Figure 23).

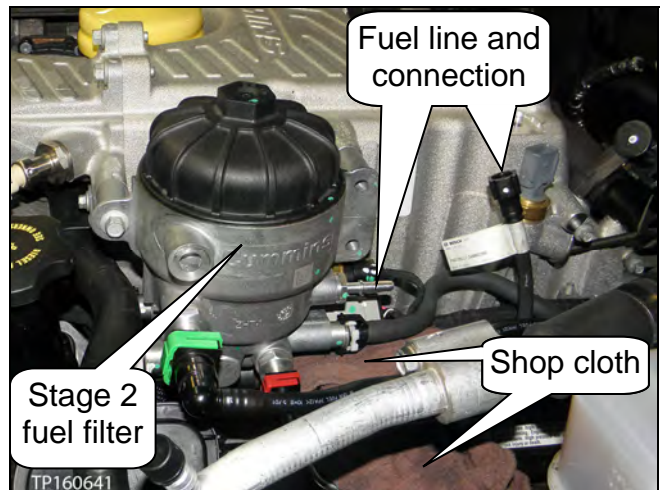

Figure 22

CAUTION: Make sure nothing (dirt, debris, etc.) gets inside the fuel system. Particles as small as 3 microns may damage fuel system components.

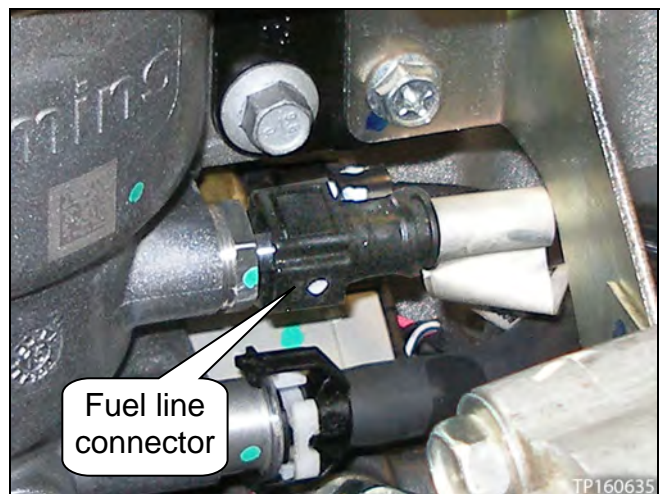

Figure 23

d. Carefully move and secure the fuel line out of the way with a tie strap (see Figure 24).

- Put a plug in the fuel line.
- Cap the fuel line's connection on the stage 2 fuel filter assembly (no picture shown).

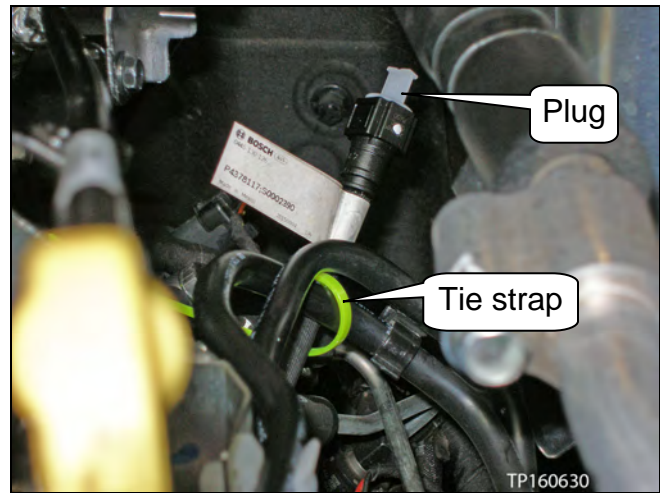

Figure 24

e. Remove the last stage 2 fuel filter assembly bolt (see Figure 25).

- The stage 2 fuel filter assembly will sit close to its normally bolted-on position.

CAUTION: Do not lean on the stage 2 fuel filter assembly at any time while it is unbolted.

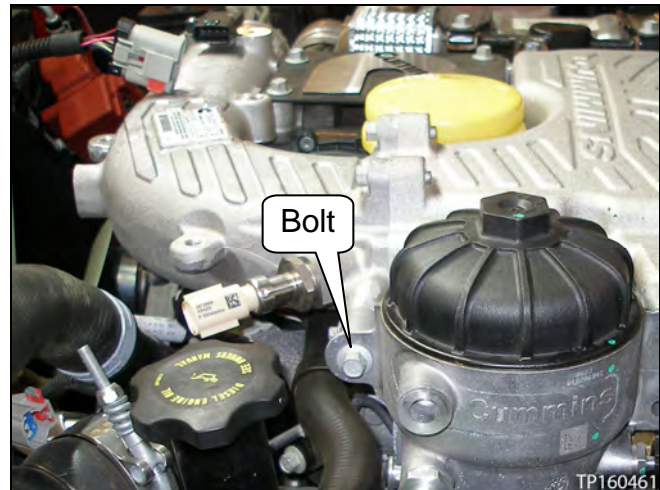

Figure 25

17. Remove the bolt, and then unclamp and disconnect the breather tube from the valve cover (see Figure 26).

- The breather tube will be removed with the air inlet connection assembly later on.

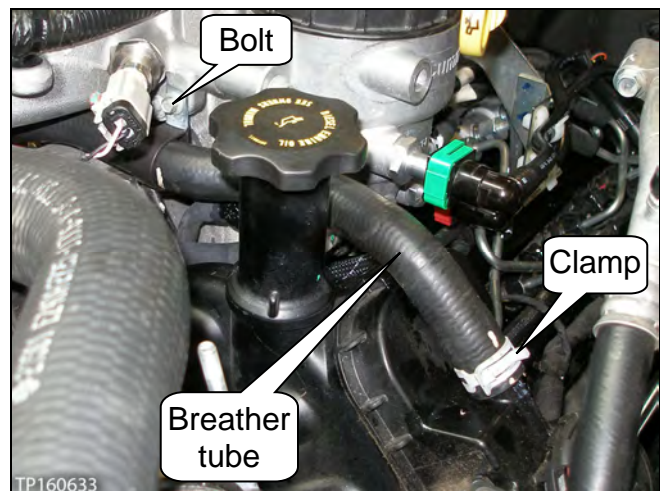

Figure 26

18. Remove the three (3) EGR valve inlet pipe bolts (see Figure 27).

- The third bolt cannot be seen in Figure 27.

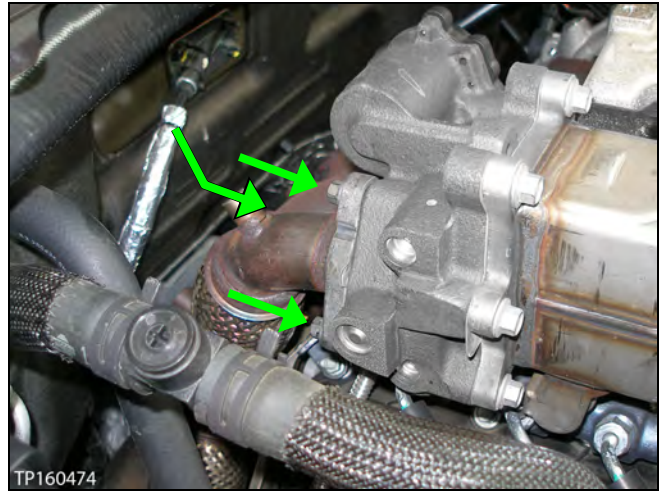

Figure 27

19. Remove the exhaust pressure sensor tube (see Figure 28 and 29).

- Unfasten the flare nut.
 - The flare nut can be accessed from the engine bay area or from under the vehicle.
- Remove Bolt 1.
- Remove Bolt 2.

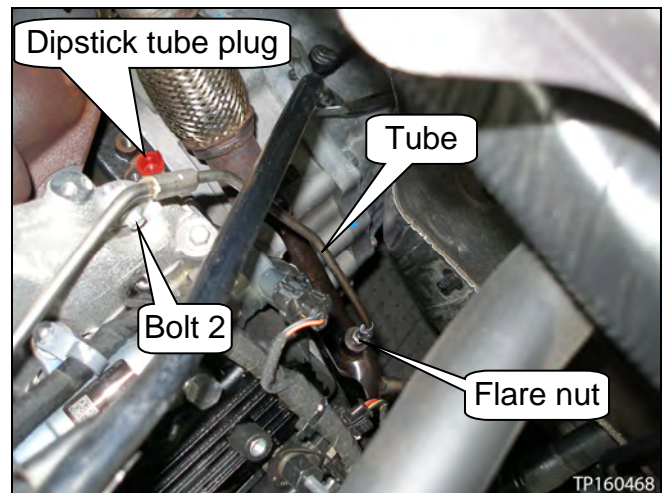

Figure 28

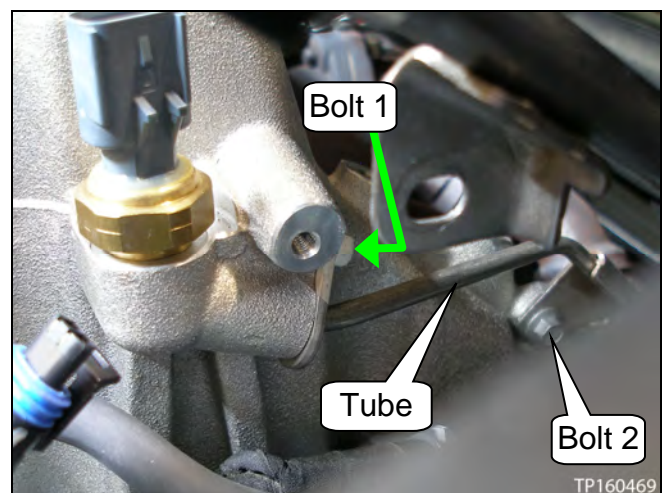

Figure 29

20. Remove the three (3) EGR bypass tube bolts (see Figure 30).

- The third bolt cannot be seen in Figure 30.

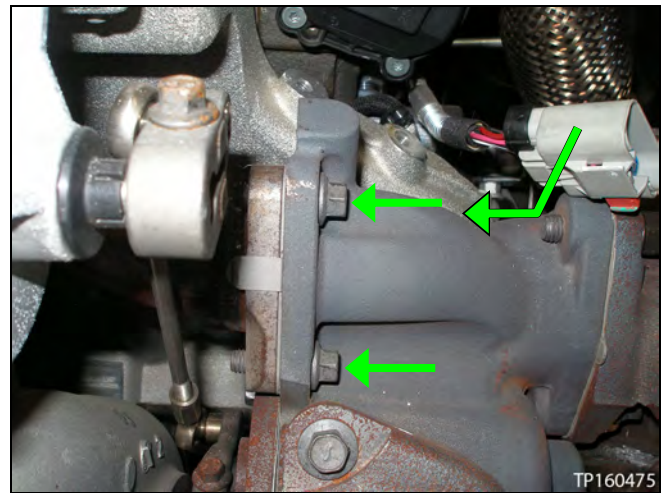

Figure 30

21. Loosen the bolt, and then dismount the **UPPER** rotary turbine control valve linkage (see Figure 31).

CAUTION: Do not unbolt the LOWER rotary turbine control valve linkage. If unbolted, the rotary turbine control valve linkage must be replaced.

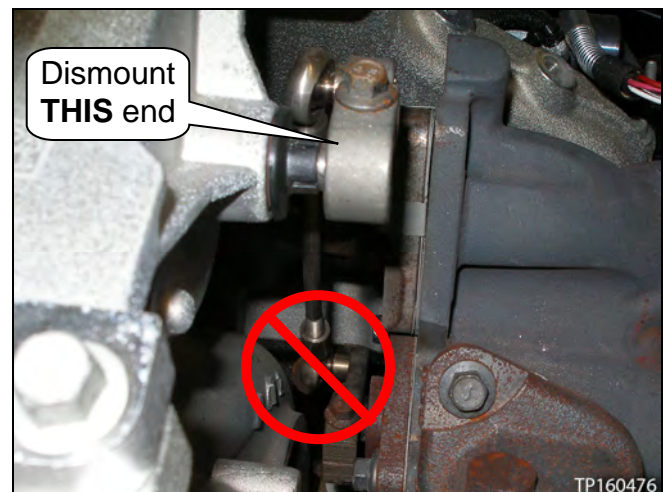

Figure 31

22. Remove both water transfer connection bolts (see Figure 32).

23. Remove the EGR bypass valve coolant tube bolt (see Figure 32).

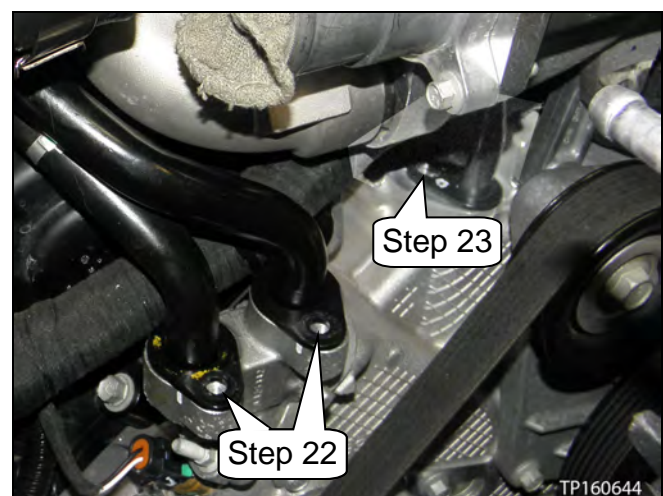

Figure 32

24. Remove the air intake connection bolt (see Figure 33).



Figure 33

25. Remove the air inlet connection assembly bolt (see Figure 34).



Figure 34

26. Loosen the air outlet hose clamp nut, and then separate from the intake manifold inlet (see Figure 35).

- Make sure to cover both openings with tape.



Figure 35

27. Disconnect the EGR temperature sensor connector (see Figure 36 and 37).

- This sensor is located under the front of the intake manifold.

NOTE: The EGR temperature sensor may need to be disconnected during removal of the intake manifold. Its locking tab may not be accessible otherwise.

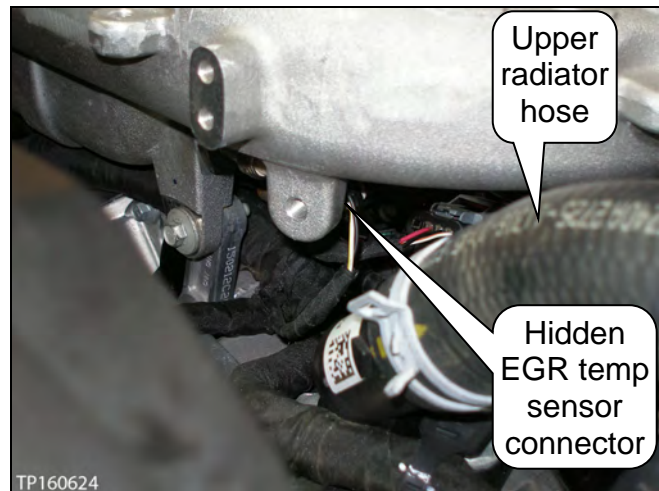

Figure 36

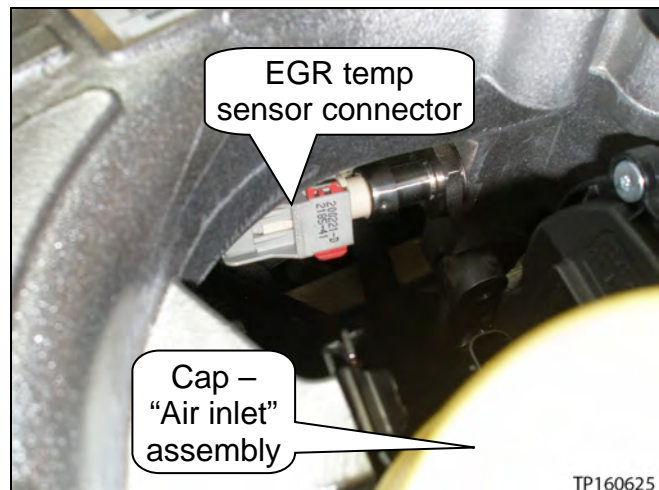

Figure 37

28. Remove the eight (8) intake manifold bolts, and then carefully remove the intake manifold assembly.

- See bolt locations in Figure 38 and 39.
- If not done yet, disconnect the EGR temperature sensor connector during intake manifold removal (see page 18, step 27).

CAUTION: Due to its weight and location, use proper lifting equipment or assistance when lifting and removing the intake manifold assembly.

NOTE: The EGR bypass valve coolant tube may come out with the intake manifold assembly. This is okay.

- See page 16, step 23 for tube identification.

NOTE: Three of the intake manifold bolts on the “EGR valve” side cannot be seen in Figure 39.

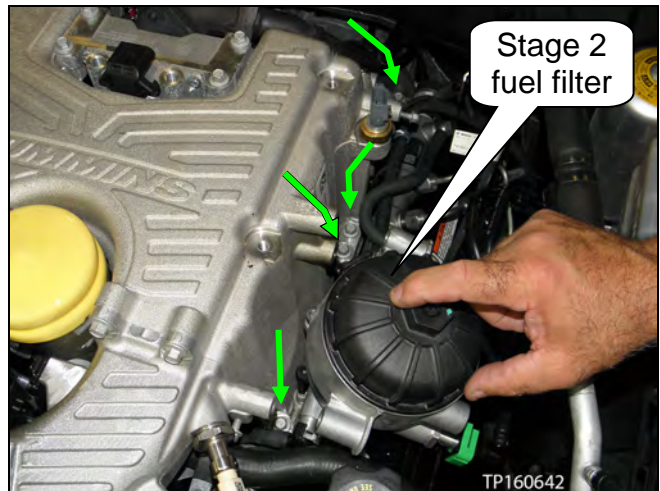

Figure 38

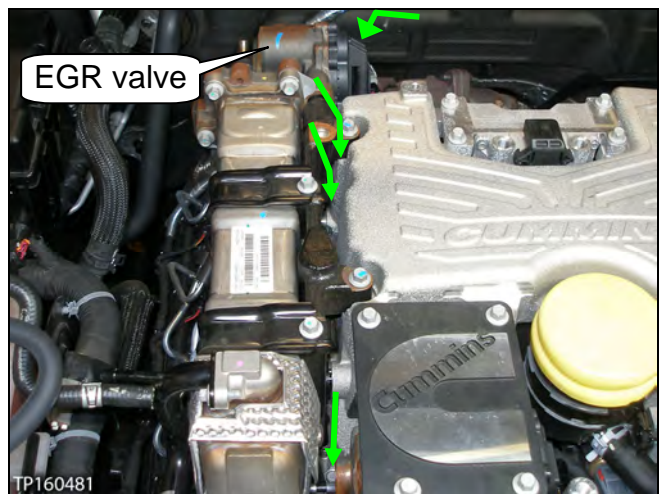

Figure 39

29. Remove any remaining intake manifold gaskets, and then install plugs and caps (yellow and red colored) where shown in Figure 40.

CAUTION: Failure to cover all engine, coolant, and fuel system openings may allow dirt/debris to enter, causing engine and/or fuel system damage.

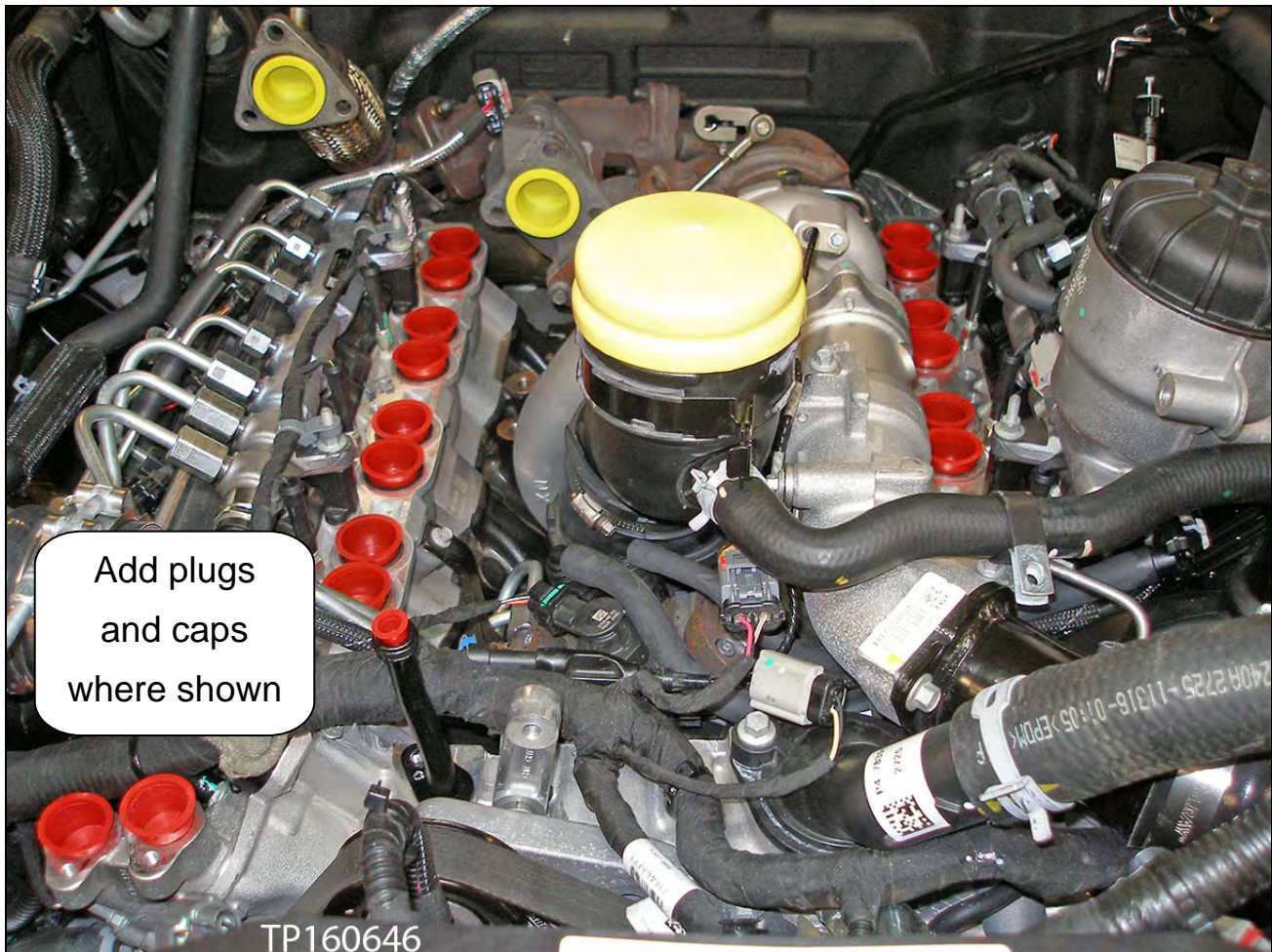

Figure 40

30. Unbolt the high pressure turbocharger from the low pressure turbocharger (see Figure 41).

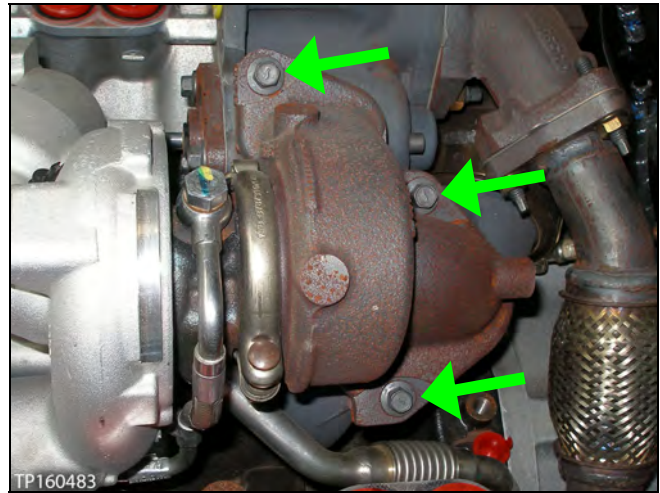

Figure 41

31. Disconnect the vacuum hose (see Figure 42).

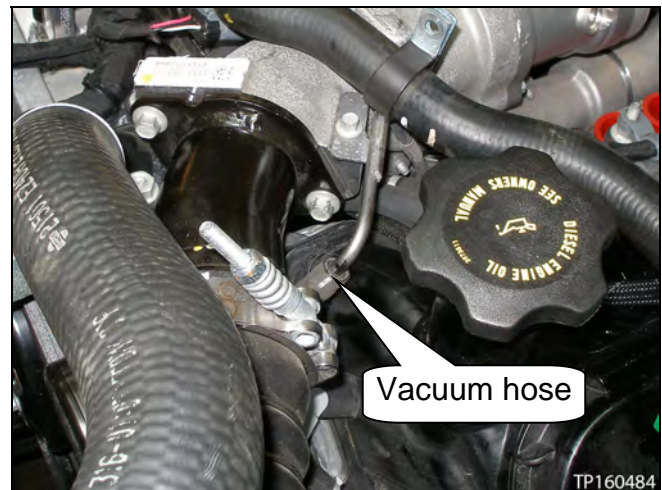

Figure 42

32. Loosen the charge-air cooler outlet tube clamp, and then separate from the turbocharger compressor outlet (see Figure 43).

- Make sure to cover both openings with tape.



Figure 43

33. Disconnect the connectors for the low pressure turbocharger boost pressure sensor and high pressure turbocharger speed sensor (see Figure 44).

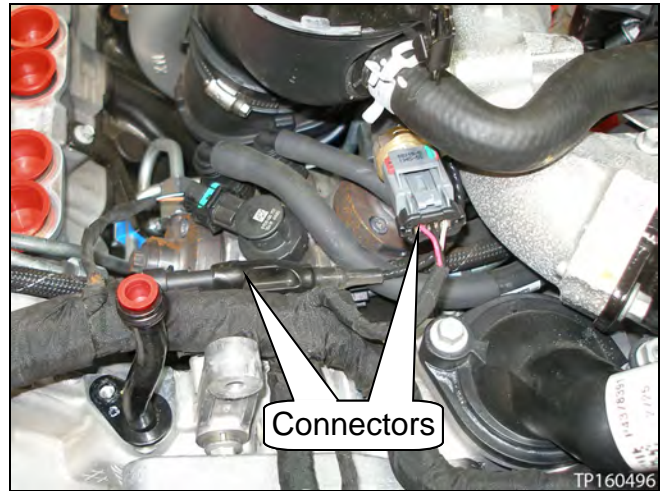

Figure 44

34. Loosen the clamp, and then remove the air inlet connection assembly (see Figure 45).

- Leave the cap on.

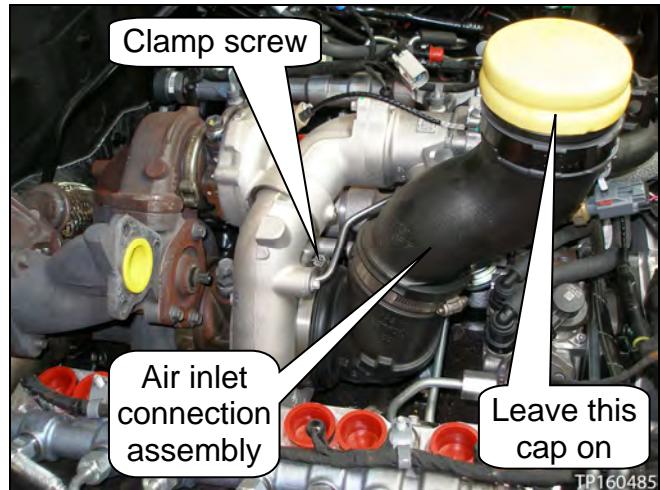

Figure 45

35. Cover the low pressure turbocharger inlet (see Figure 46).

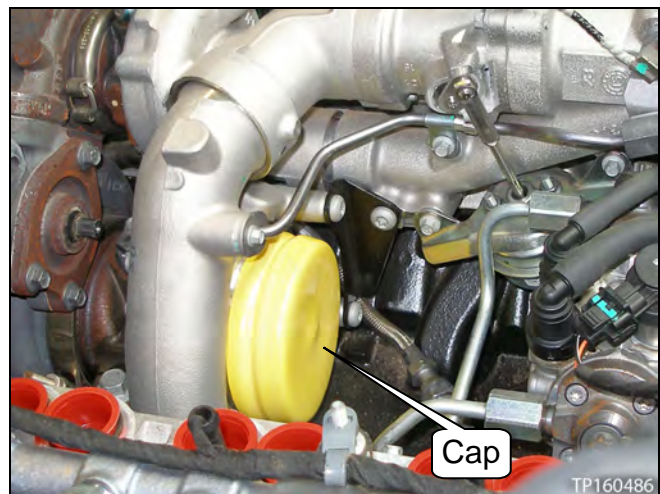

Figure 46

36. Remove the banjo bolts for the high pressure and low pressure turbochargers (see Figure 47 and 48).

- Also remove the banjo bolts' copper gaskets.
 - These gaskets will not be reused.
- Cover the low pressure turbocharger oil hole with tape.

IMPORTANT: Both banjo bolts must be removed in order to remove the HP turbocharger assembly.

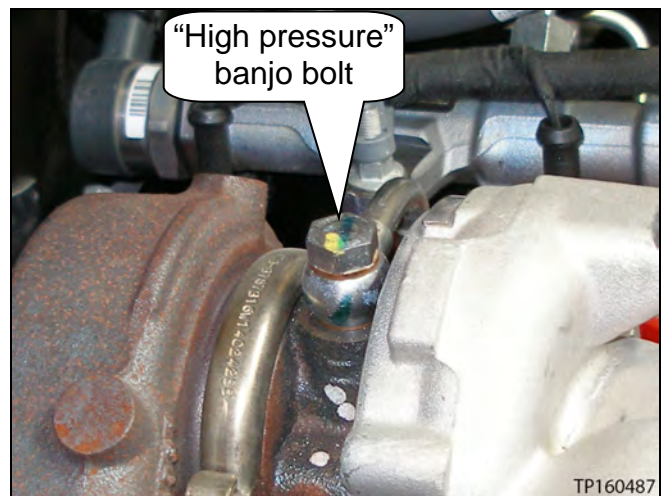

Figure 47

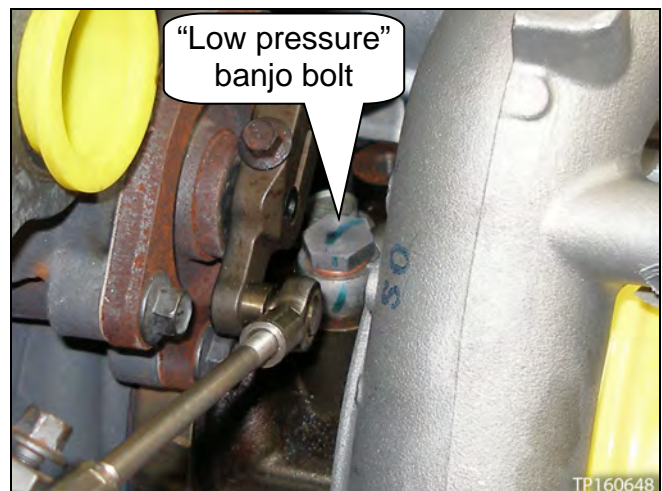

Figure 48

37. Remove the three (3) bolts, and then remove the low pressure turbocharger boost pressure sensor tube (see Figure 49).

- Cover the hole with tape (see Figure 50).

38. Unbolt, unclamp, and then remove the high pressure turbocharger speed sensor (see Figure 49).

- Cover the hole with tape (see Figure 50).

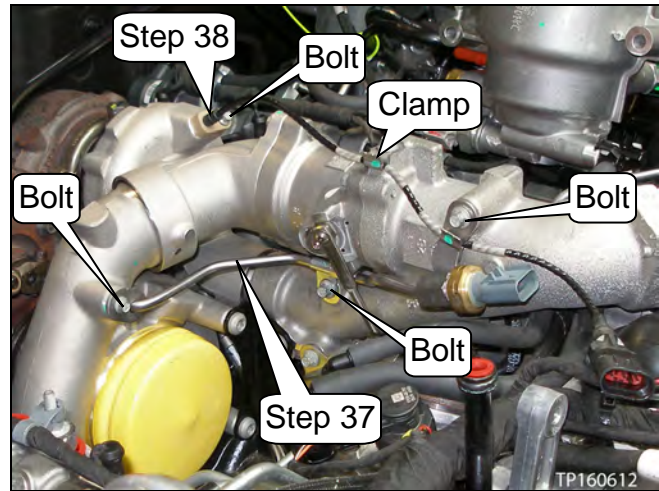

Figure 49

39. Remove the T45 TORX® bolt (see Figure 50).

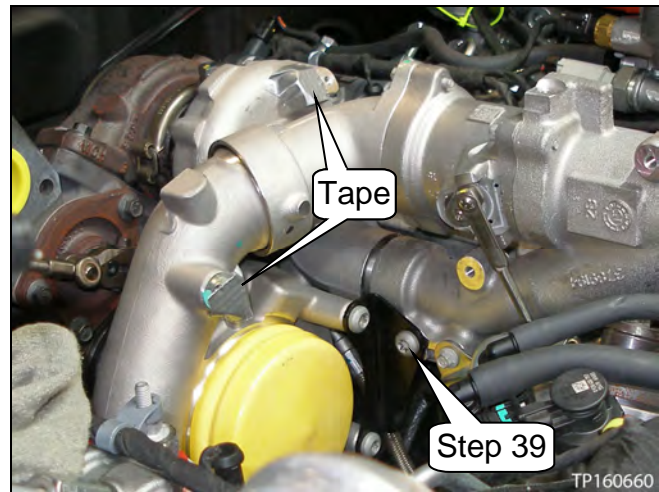

Figure 50

40. Unfasten the oil drain line bolt (see Figure 51).

41. Remove the high pressure turbocharger assembly from the vehicle.

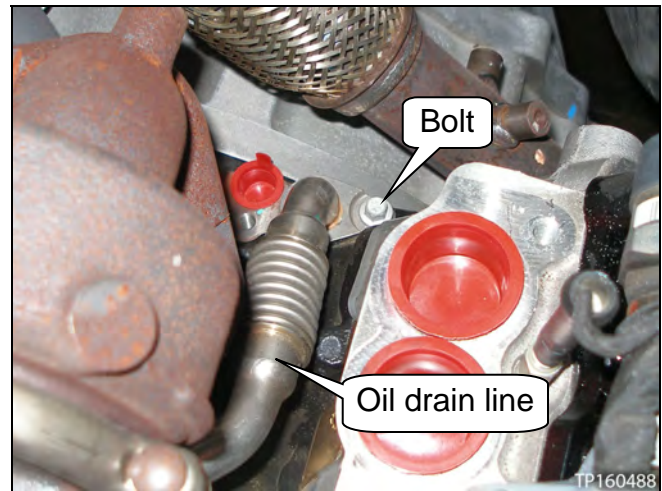

Figure 51

42. Cover the following openings:

- Oil drain line-to-block hole
- Low pressure turbocharger exhaust port
- Low pressure turbocharger outlet

➤ See Figure 52 and 53 for all locations.

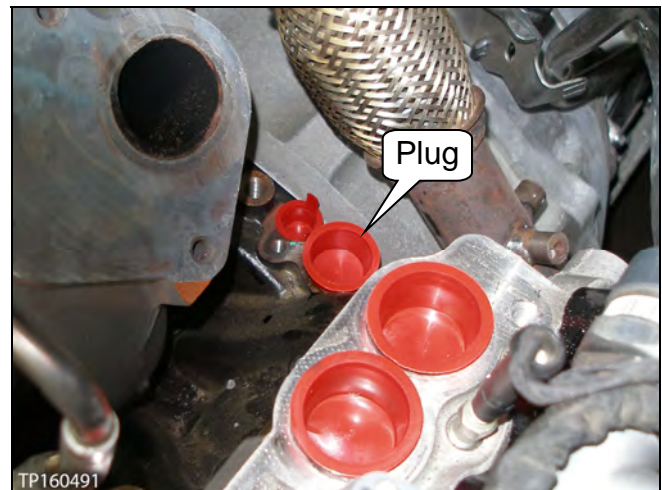

Figure 52

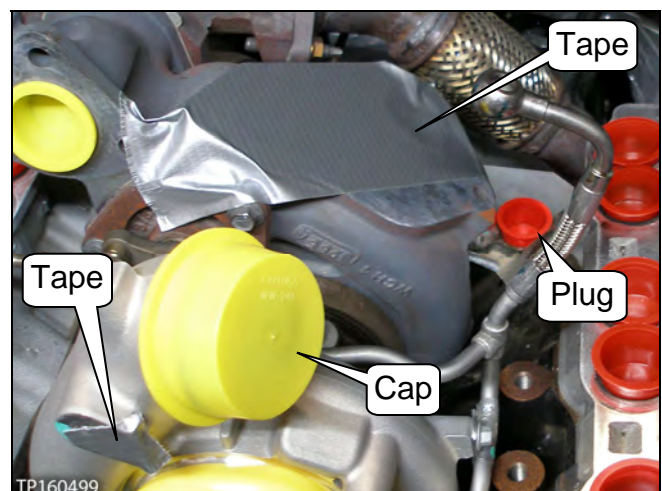

Figure 53

43. Remove the bolts, and then remove the oil drain line (see Figure 54).

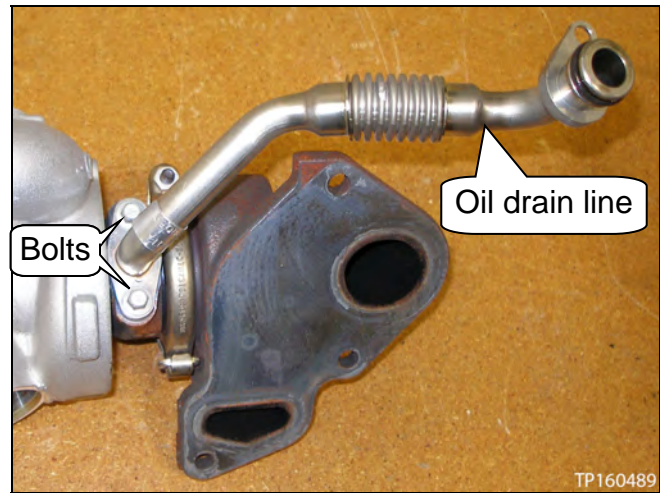

Figure 54

44. Remove the bolts, and then separate the high pressure turbocharger from the turbocharger compressor outlet connection assembly (see Figure 55 and 56).

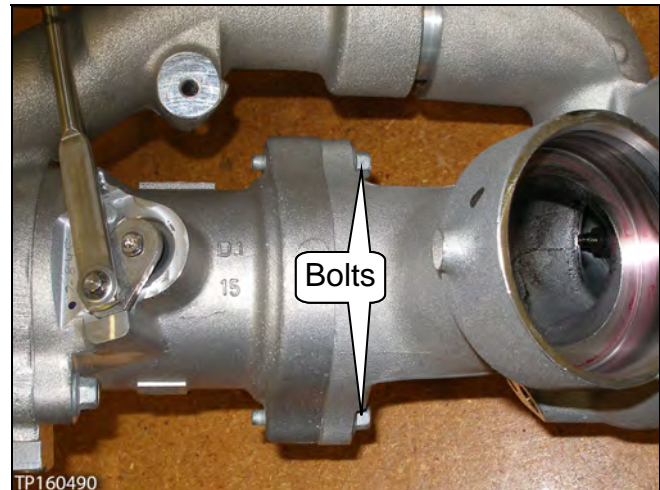

Figure 55

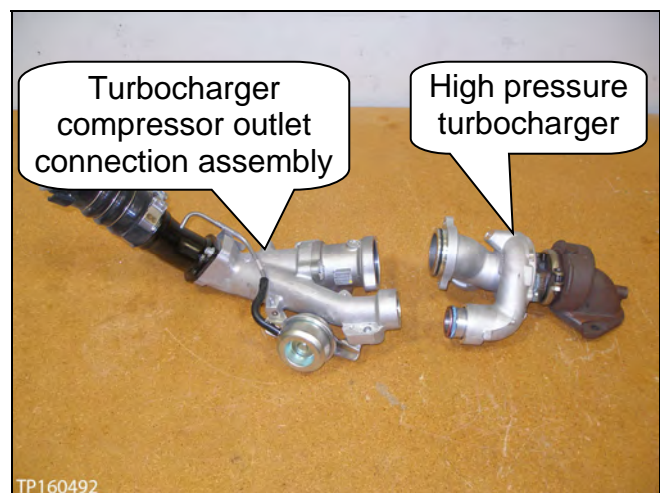

Figure 56

HP Turbocharger: Compressor Housing and Wheel Inspection

Inspect where shown below. A flashlight should be sufficient, but use borescope J-51951 as needed (see page 27 and 28).

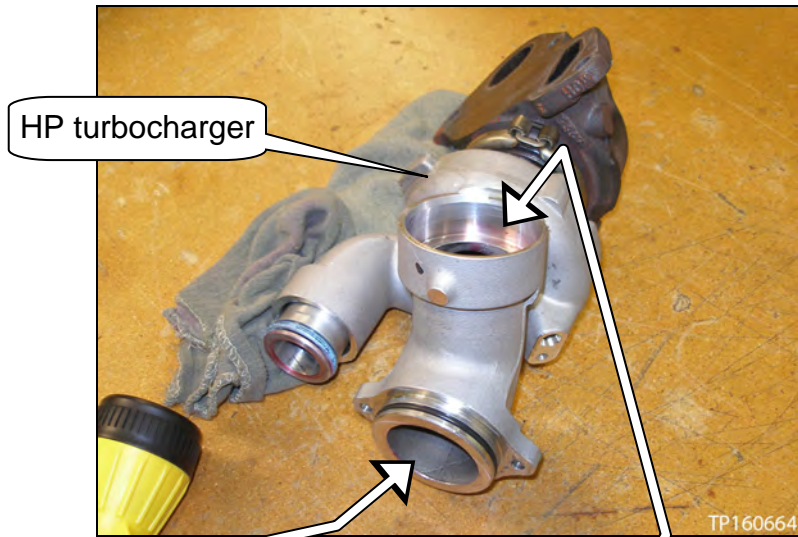

Figure 1A

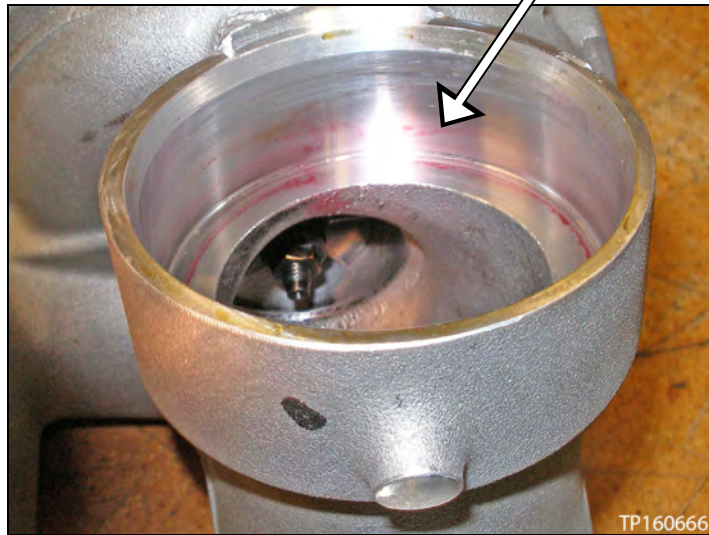

Figure 2A

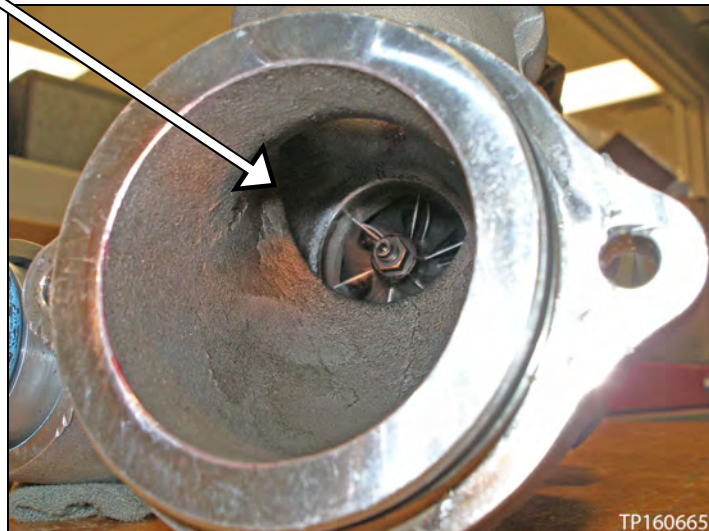

Figure 3A

Compressor housing and wheel inspection (continued)

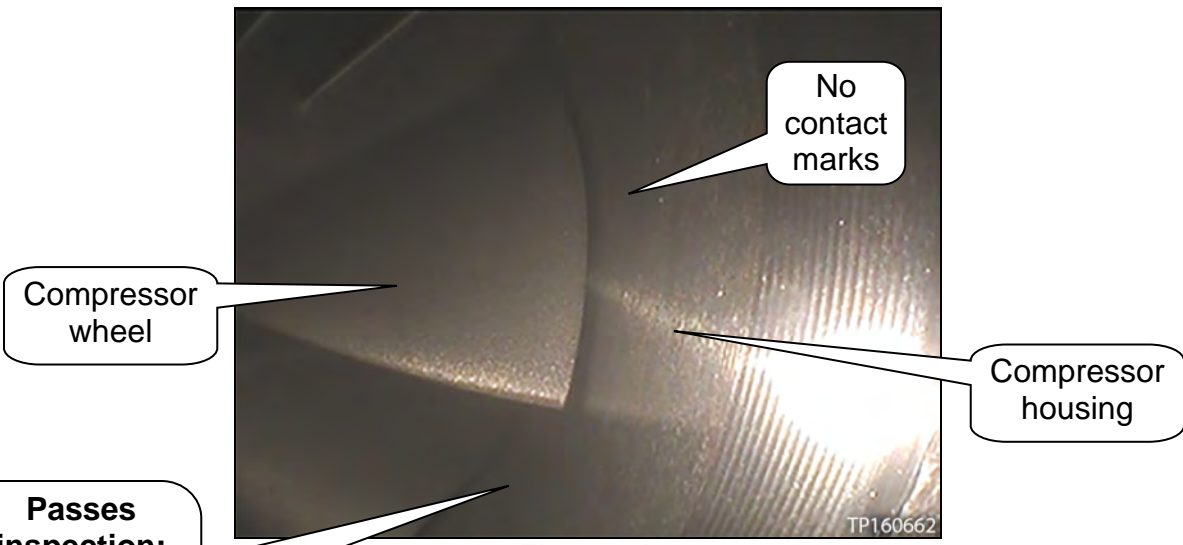

Figure 4A

Passes inspection:
Replace HP turbocharger
(go to page 29)

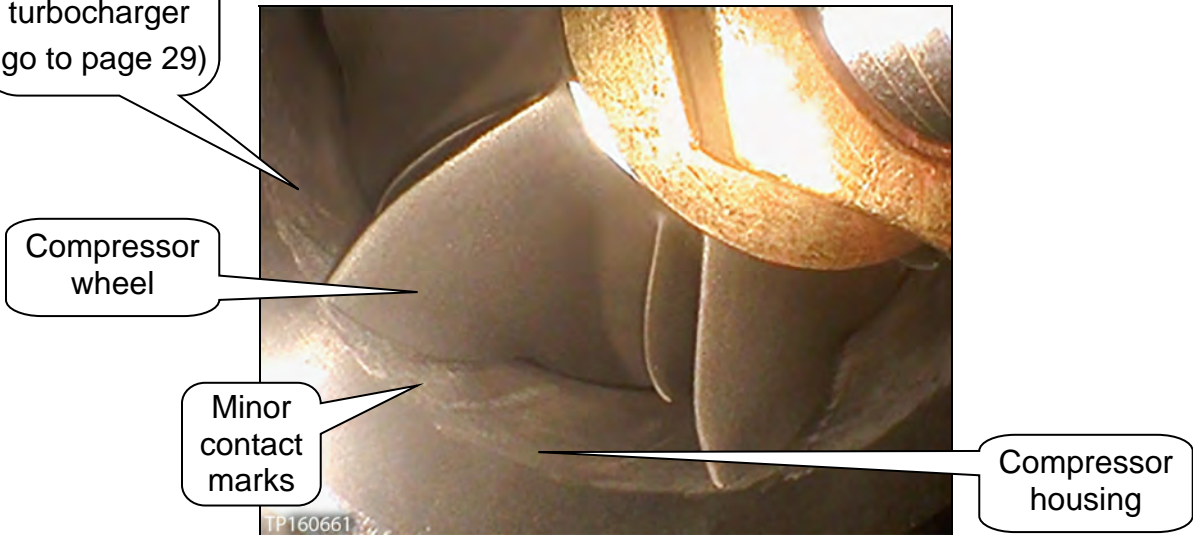

Figure 5A

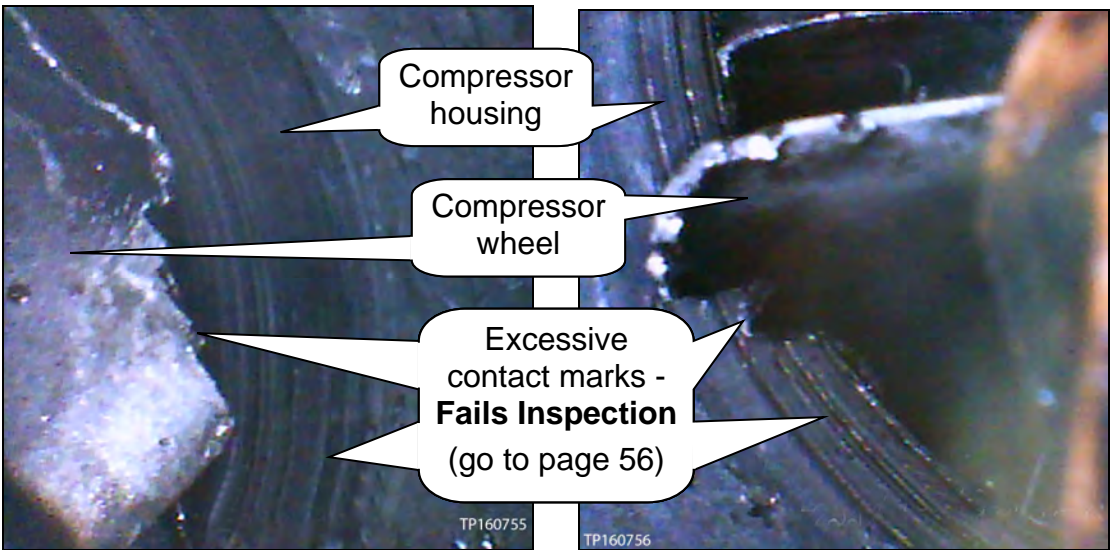

Figure 6A

Figure 7A

Install High Pressure Turbocharger Assembly

1. Remove the high pressure turbocharger from its packaging, and then install tape where shown in Figure 57.

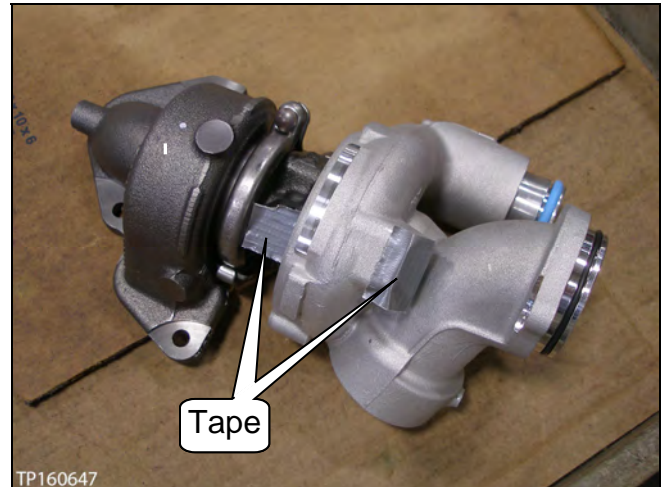

Figure 57

2. Install the oil drain line (see Figure 58).
 - Use a new gasket and O-ring.
 - Cummins O-ring P/N: 3029820.

NOTE: All parts in the parts kit are labeled with Cummins part numbers. See **Parts Cross Reference List**.

- Bolts torque: 9.8 N•m (1.00 kg•m, **87 in-lbs**)
- Coat the O-ring with clean engine oil.

NOTE: The turbocharger compressor outlet connection assembly will be installed later on.

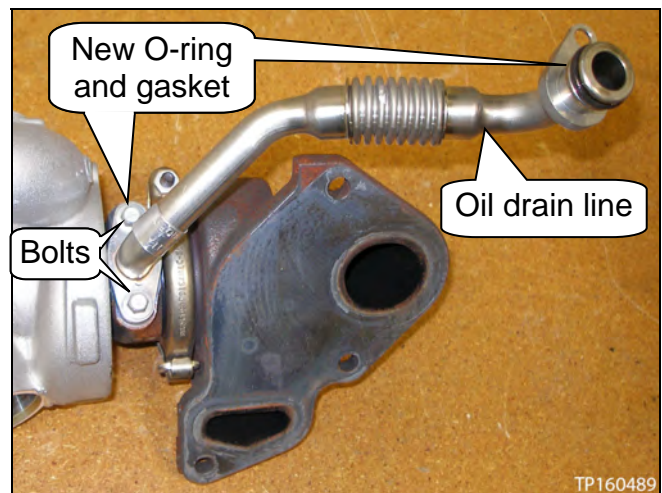

Figure 58

3. Remove the cap, tape, and plug shown in Figure 59.
4. Replace the low pressure turbocharger's O-ring with a new one (see Figure 59).
 - Cummins P/N: 2835314.
 - See **Parts Cross Reference List**.
 - Coat the O-ring with P80[®] Emulsion (see **PARTS INFORMATION** and the **CAUTION** below it).

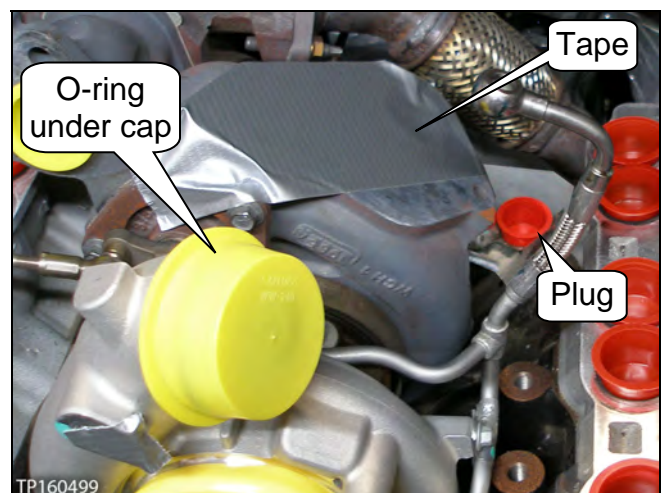

Figure 59

5. Position the new high pressure turbocharger on the low pressure turbocharger (see Figure 60).
 - a. Install a new gasket.
 - A gasket fits between the two turbochargers.
 - b. Apply suitable anti-seize to the bolt's threads.
 - c. Loosely install the three (3) bolts (see Figure 61).

NOTE: There are extra bolts in the parts kit. Replace as needed.

CAUTION: Do not lean on the stage 2 fuel filter assembly at any time while it is unbolted (see Figure 60).

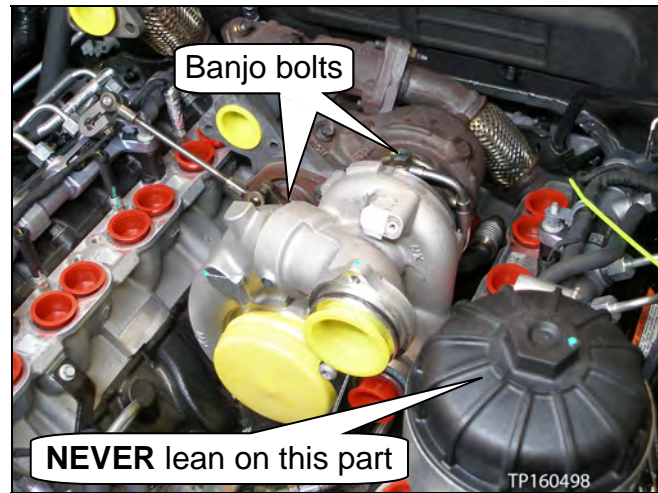

Figure 60

6. Remove the tape, and then install both banjo bolts finger tight with new copper gaskets (see Figure 61).
 - Do not use the old copper gaskets.
 - The “low pressure” banjo bolt cannot be seen in Figure 60 or 61.
 - Do not torque the banjo bolts at this time.

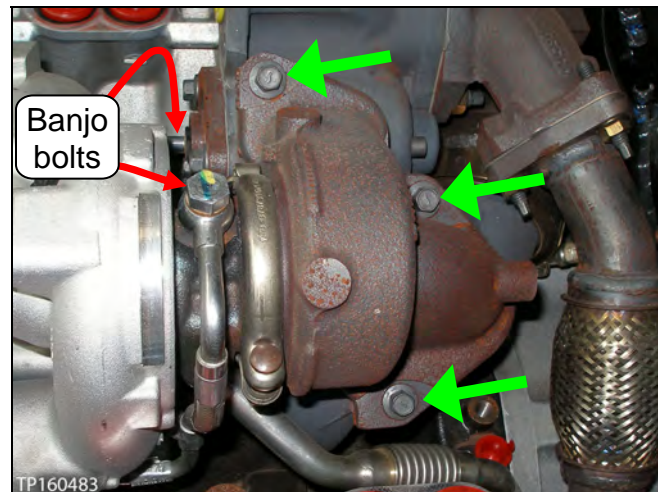

Figure 61

7. Fully insert the oil drain line with new O-ring into the engine block, and then install the bolt (see Figure 62).
 - Make sure the O-ring is coated with engine oil.
 - Bolt torque: 9.8 N•m (1.00 kg-m, **87 in-lbs**)

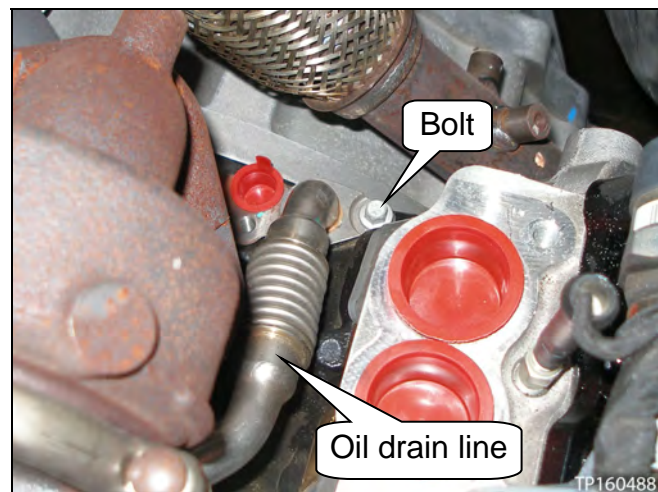

Figure 62

8. Install the turbocharger compressor outlet connection assembly.
 - a. Remove the cap and plug from the high pressure turbocharger.
 - b. Coat the O-rings with P80[®] Emulsion (see **CAUTION** under **PARTS INFORMATION**).
 - c. Put the turbocharger compressor outlet connection assembly in place.
 - d. Install two new bolts (see Figure 63).
 - Do not reuse the old bolts. The new bolts come with a thread lock coating.
 - e. Install the T45 TORX[®] bolt finger tight (see Figure 63).
 - There are extra TORX[®] bolts in the parts kit. Replace this bolt as needed.

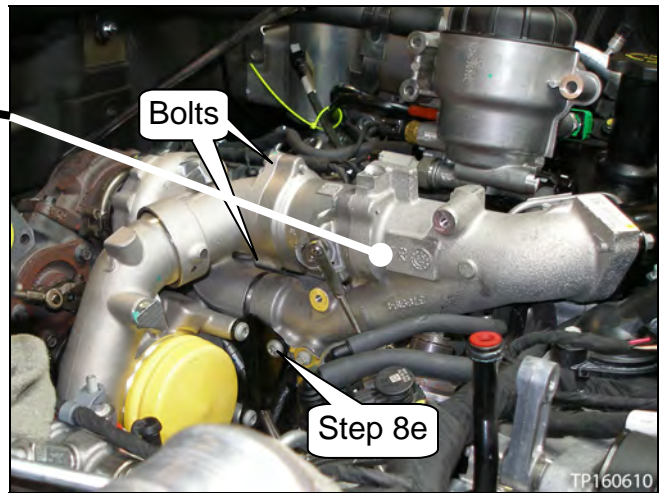

Figure 63

9. Torque the three (3) bolts shown in Figure 64.
 - Bolts torque: 32 N•m (3.3 kg-m, **24 ft-lbs**)

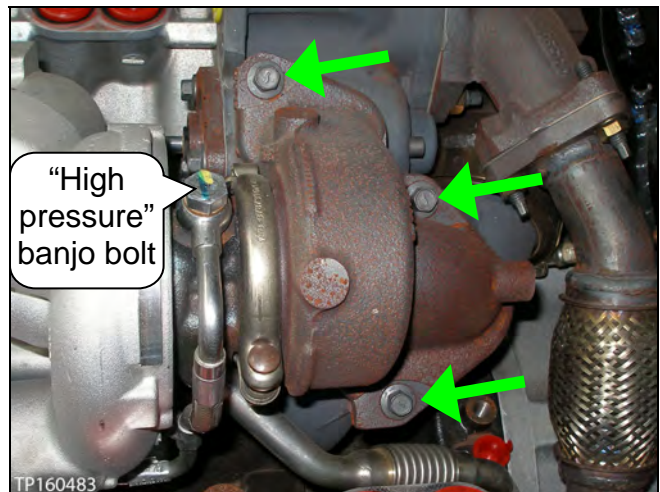

Figure 64

10. Torque the banjo bolts (see Figure 64 and 65).
 - “High Pressure” banjo bolt torque: 22 N•m (2.2 kg-m, **16 ft-lbs**)
 - “Low Pressure” banjo bolt torque: 34 N•m (3.5 kg-m, **25 ft-lbs**)

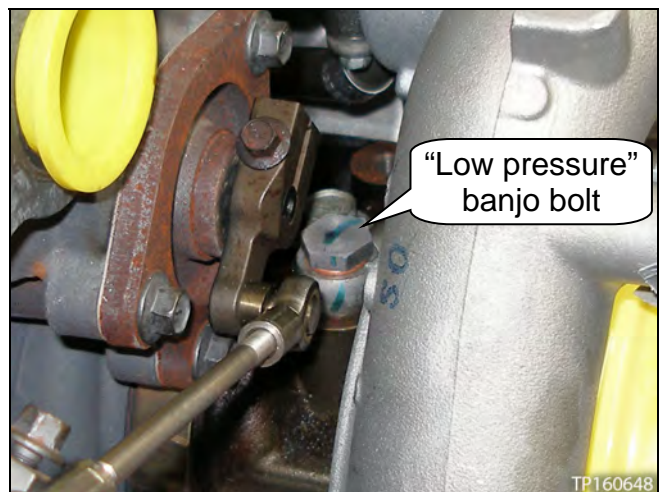

Figure 65

11. Torque the T45 TORX® bolt, and two (2) new bolts shown in Figure 66.

- T45 TORX® torque: 18 N•m (1.8 kg-m, **13 ft-lbs**)
- Bolts torque: 10 N•m (1.0 kg-m, **84 in-lbs**)

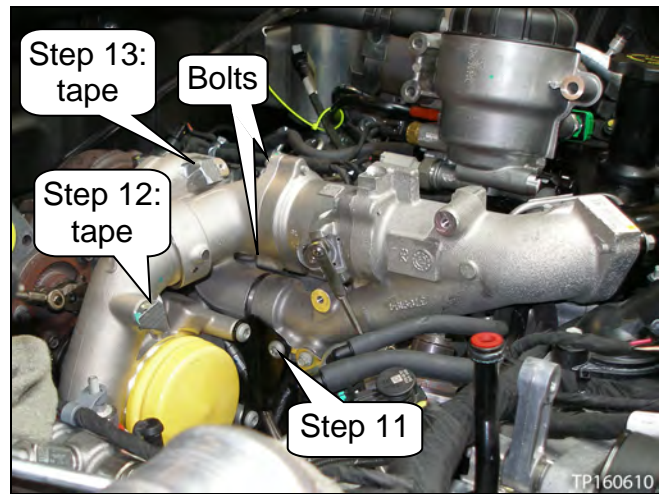

Figure 66

12. Install the low pressure turbocharger boost pressure sensor tube (see Figure 67).

- Remove the tape (see Figure 66).
- Replace the O-ring with a new one and coat it with P80® Emulsion.
 - See **PARTS INFORMATION** and the **CAUTION** below it.
- Cummins P/N: 3779750
 - See **Parts Cross Reference List**.
- Bolt **A** torque: 10.2 N•m (1.0 kg-m, **96 in-lbs**)

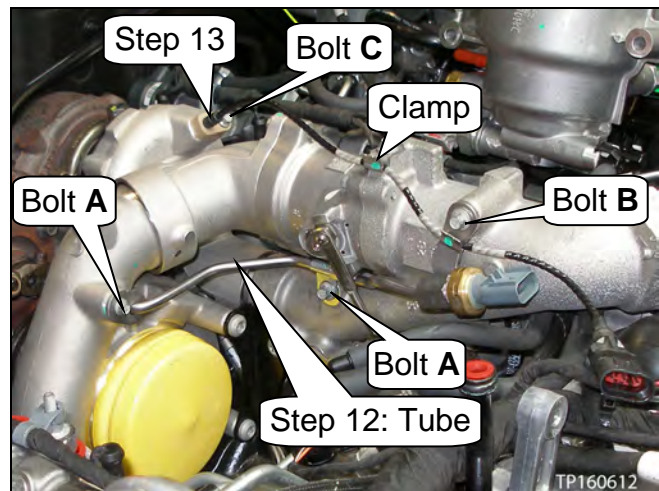

Figure 67

13. Install the high pressure turbocharger speed sensor (see Figure 67).

- Remove the tape (see Figure 66).
- Replace the O-ring with a new one and coat it with P80® Emulsion.
 - Cummins P/N: #3787623
 - See **PARTS INFORMATION** and the **CAUTION** below it.
- Bolt **B** torque: 10.2 N•m (1.0 kg-m, **96 in-lbs**)
- Bolt **C** torque: 5.5 N•m (0.56 kg-m, **49 in-lbs**)

14. Remove the cap from the low pressure turbocharger, and then install the air inlet connection assembly (see Figure 68).

- Clamp screw torque: 4.5 N•m (0.46 kg-m, **40 in-lbs**)

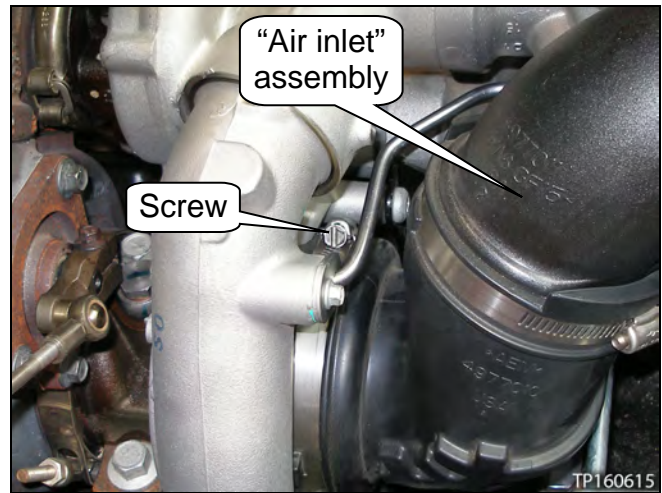

Figure 68

- The air inlet connection assembly is properly mated to the low pressure turbocharger when the notch is seated in the cut-out (see Figure 69 and 70).

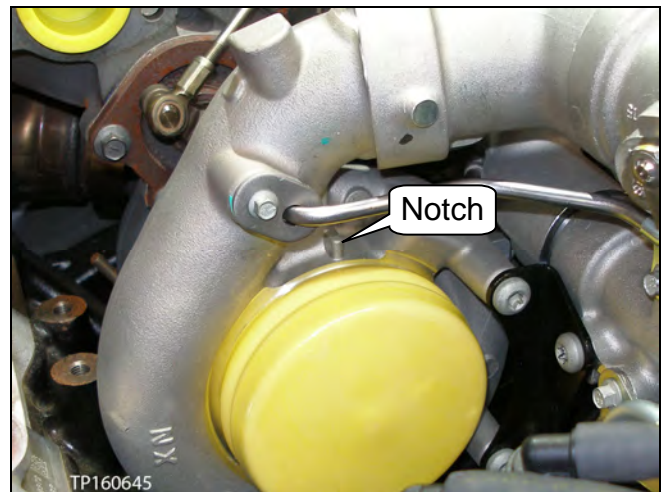

Figure 69

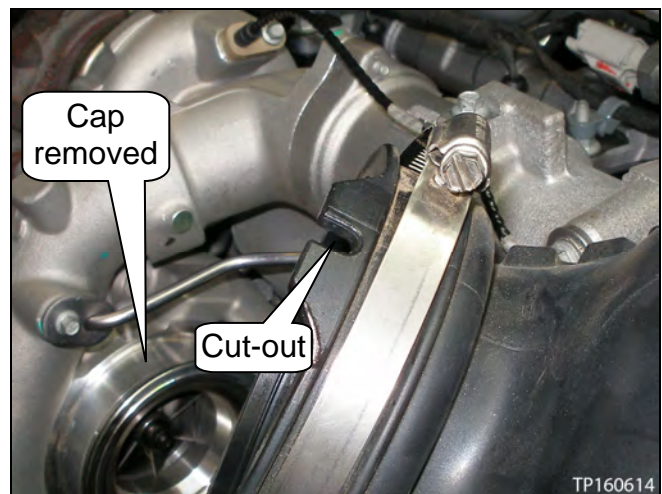

Figure 70

15. Connect the two (2) connectors (see Figure 71).

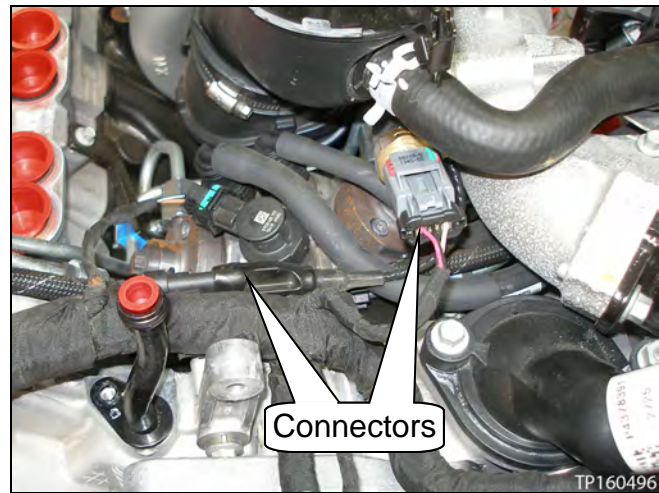

Figure 71

16. Connect the vacuum hose (see Figure 72).

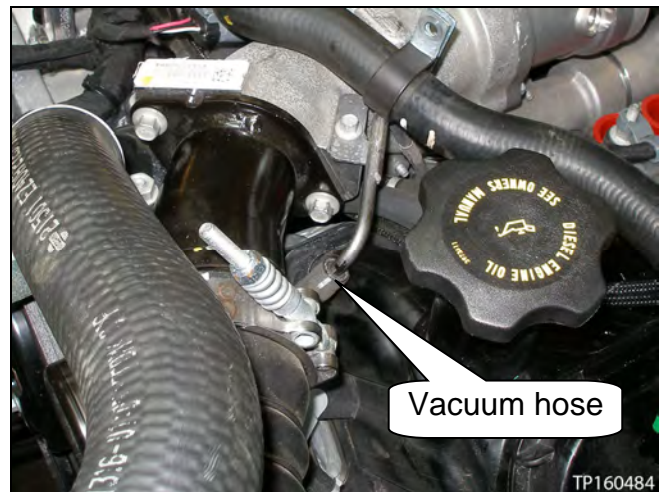

Figure 72

17. Remove the tape, and then connect the charge-air cooler tube to the charge-air cooler outlet hose (see Figure 73).

- Clamp nuts torque: 10 N•m (1.0 kg-m, **84 in-lbs**)

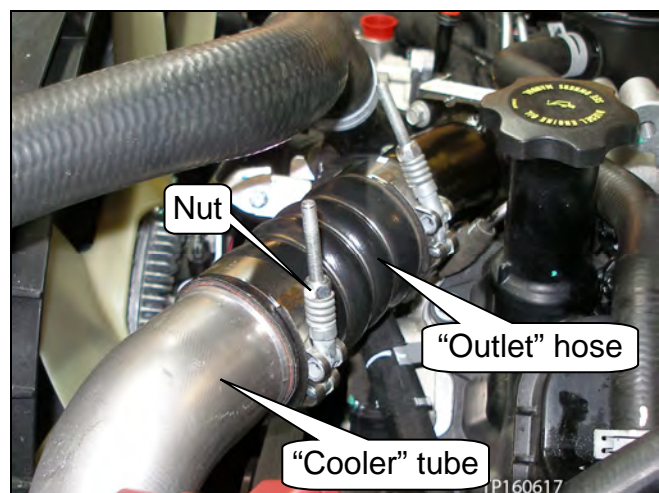

Figure 73

18. Remove the plug, and then remove the EGR bypass valve coolant tube (see Figure 74).

- Replace both O-rings with new ones (# 4977258), and then coat them with P80® Emulsion.
 - See the **Parts Cross Reference List, PARTS INFORMATION,** and the **CAUTION** below it.

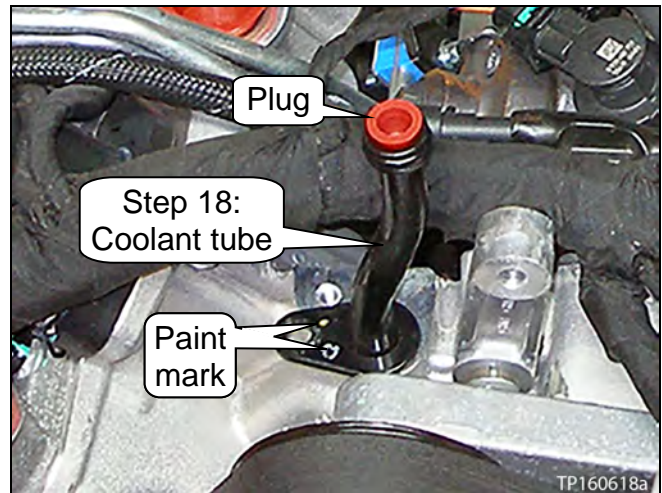

Figure 74

19. Fully insert the EGR bypass valve coolant tube to the intake manifold (see Figure 75).

- The upper O-ring will hold the EGR bypass valve coolant tube in place.

NOTE: The EGR bypass valve coolant tube only needs to be in the generally correct position at this time.

NOTE: Make sure the paint mark(s) are facing upward as shown in Figure 74 once the intake manifold is installed.

- For additional reference, also see page 38, Figure 84.

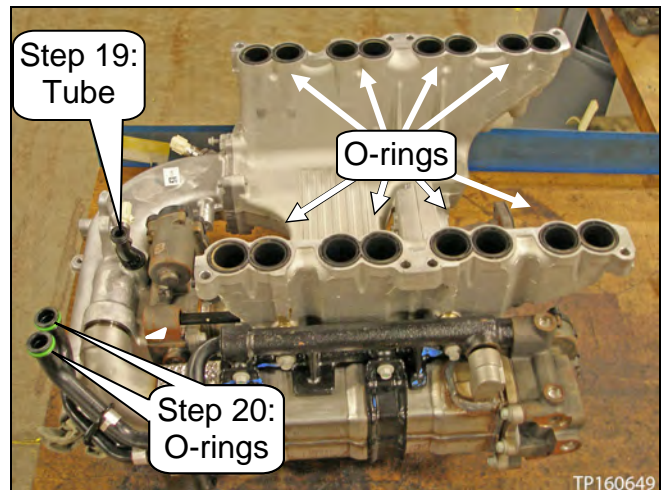

Figure 75

20. Replace the two water transfer connection tube O-rings with new ones (see Figure 75).

- Coat the O-rings (# 5266152) with P80 Emulsion.
 - See the **Parts Cross Reference List, PARTS INFORMATION** and the **CAUTION** below it.

21. Install all O-ring gaskets in the intake manifold (see Figure 75).

- Make sure the surfaces the O-ring gaskets come in contact with are clean.
- Make sure all O-rings are in place and properly seated (see Figure 76).



Figure 76

22. Replace the EGR bypass tube gasket with a new one (see Figure 77).

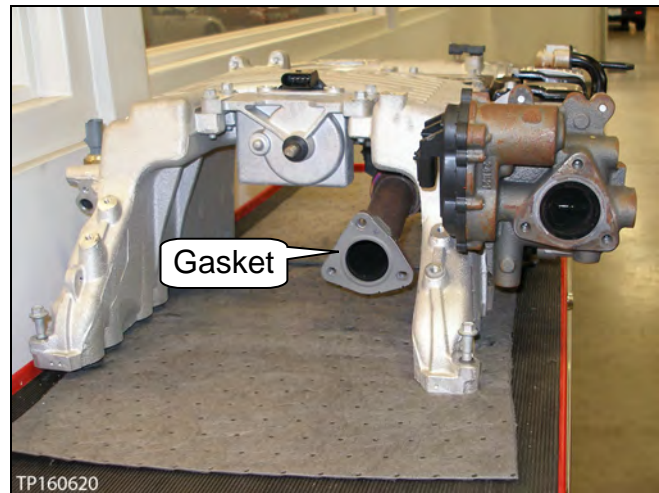

Figure 77

23. Install all eight (8) intake manifold bolts in place (see Figure 78).

- Use new bolts from the parts kit. These bolts come with O-rings. They are to hold the bolts in place.
- Figure 78 does not show the four bolts on the other side of the intake manifold.

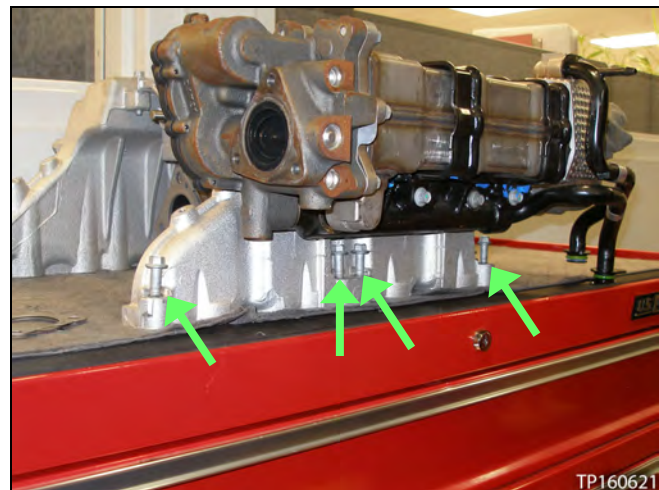

Figure 78

- Push down enough for the O-rings to hold the bolts in place, but not enough for the bolts to stick out the bottom (see Figure 79).

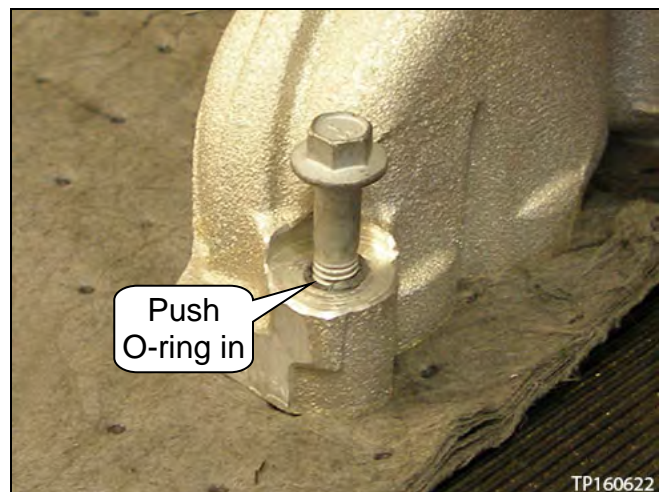

Figure 79

24. Remove all plugs shown in Figure 80 now.

- Do not remove the cap on the air inlet connection assembly.
- Plugs can be reused. Put them back in Kit J-54423 (see page 2).
- Position the rotary turbine control valve linkage as far as possible on the driver side of the EGR bypass flange.

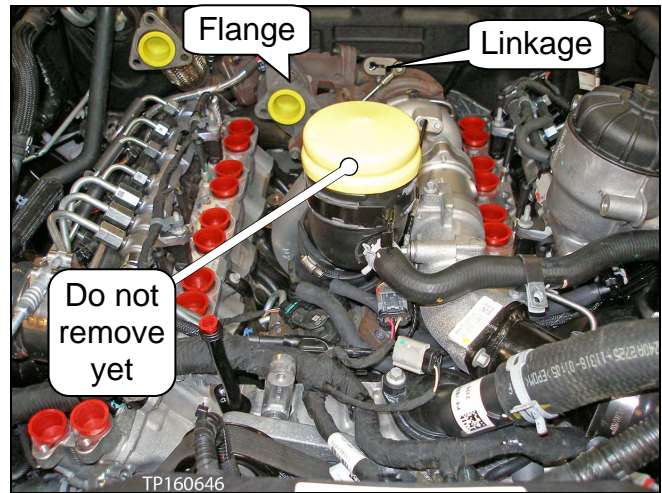

Figure 80

25. Put the intake manifold in place (no picture shown).

- Make sure:
 - All intake manifold O-ring gaskets are properly seated.
 - The engine control harness is not being pinched by the intake manifold.
 - The EGR bypass coolant tube and both water transfer connection tubes are properly positioned and inserted (see next page, Figure 84).
 - All bolts thread in/start by hand.

CAUTION: Due to its weight and location, use proper lifting equipment or assistance when lifting and installing the intake manifold assembly.

26. Torque the bolts.

- Bolts torque: 18 N•m (1.8 kg-m, **13 ft-lbs**)
- See Figure 81 for torque sequence.

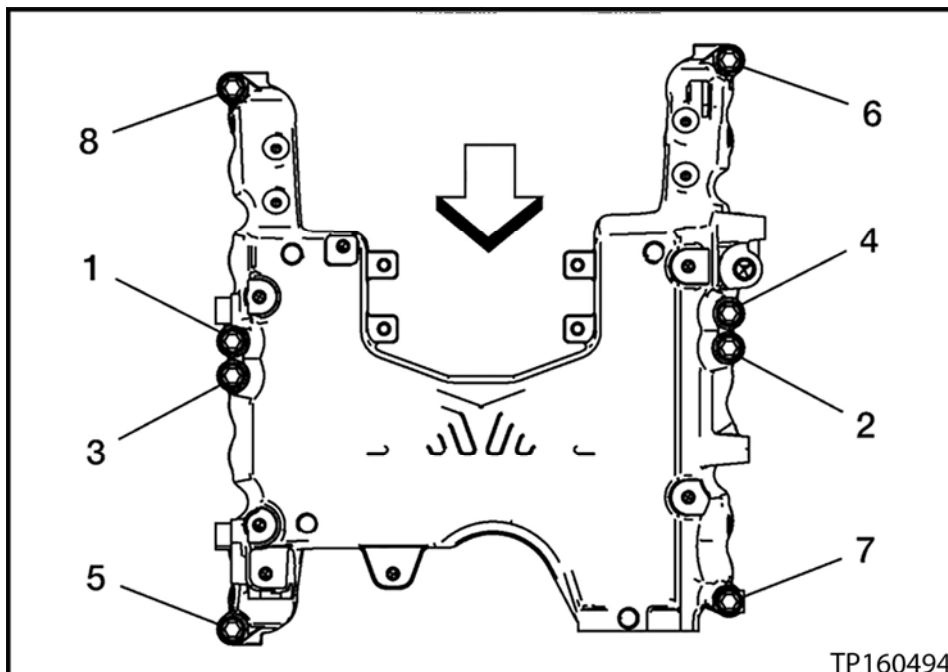

Figure 81

27. Connect the EGR temperature sensor connector (see Figure 82 and 83).

- This sensor is located under the front of the intake manifold.

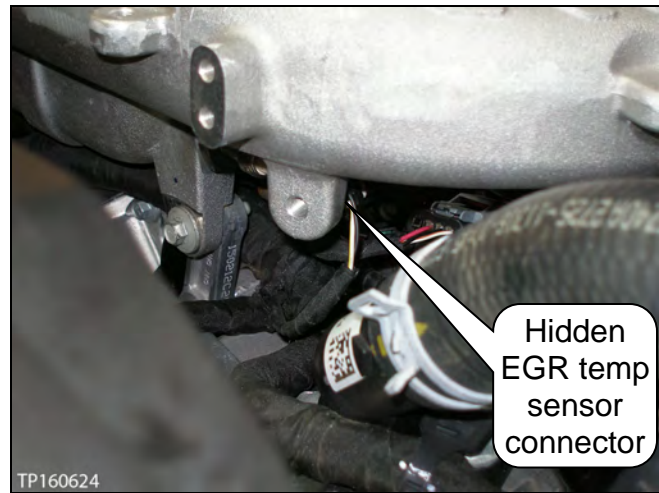

Figure 82

- Figure 83 shows the EGR temperature sensor connector when viewed between the front of the intake manifold and the air inlet connection assembly.

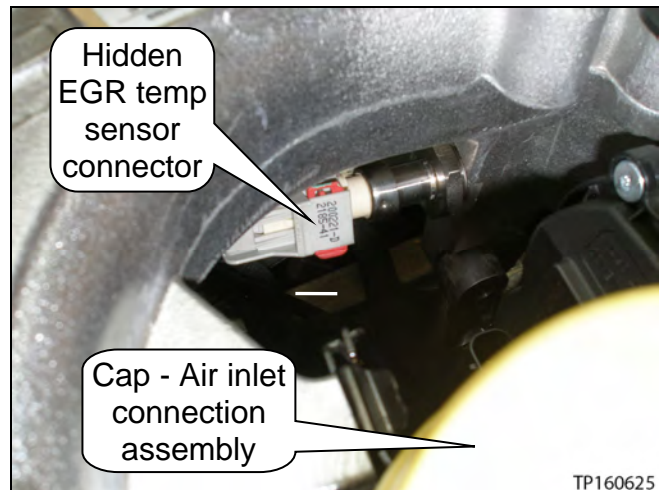

Figure 83

28. Install the bolts for the EGR bypass coolant tube and both water transfer connection tubes (see Figure 84).

- Bolts torque: 7.4 N•m (0.75 kg-m, **65 in-lbs**)

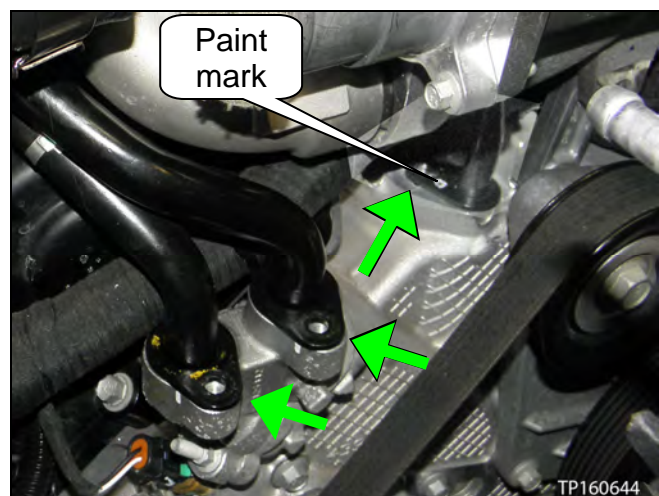

Figure 84

29. Install the air intake connection bolt (see Figure 85).

- Bolt torque: 18 N•m (1.8 kg-m, **13 ft-lbs**)



Figure 85

30. Install the air inlet connection bolt (see Figure 86).

- Bolt torque: 18 N•m (1.8 kg-m, **13 ft-lbs**)

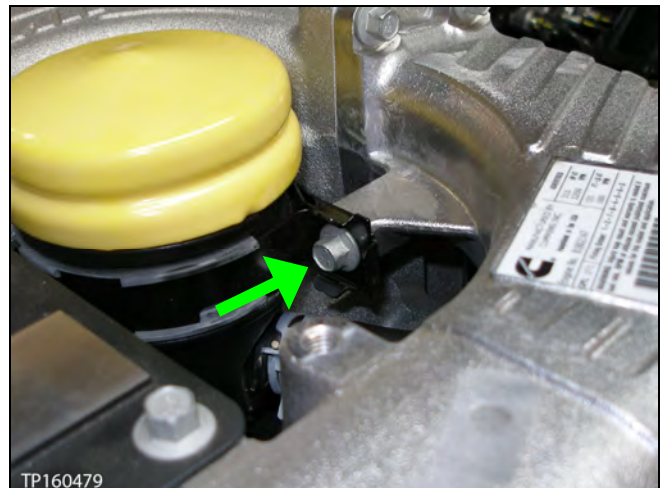

Figure 86

31. Remove the tape, and then connect the air outlet hose to the air intake connection (see Figure 87).

- Clamp nuts torque: 10 N•m (1.0 kg-m, **84 in-lbs**)



Figure 87

32. Install the three (3) EGR valve inlet pipe bolts (see Figure 88).

- Bolts torque: 23 N•m (2.3 kg-m, **17 ft-lbs**)
 - Replace the gasket. Do not reuse the old gasket.

NOTE: There are extra bolts in the parts kit. Replace as needed.

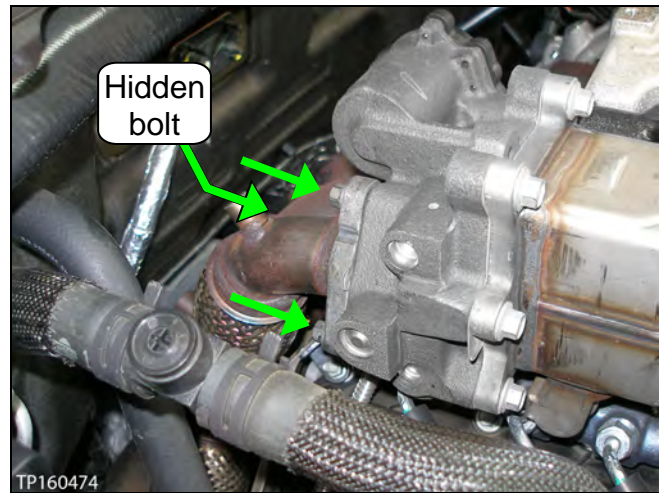

Figure 88

33. Install the three (3) EGR bypass tube bolts (see Figure 89).

- Bolts torque: 18 N•m (1.8 kg-m, **13 ft-lbs**)
 - Apply suitable anti-seize to the bolt's threads before installing.
 - Make sure the gasket has been replaced (see page 36, step 22). Do not reuse the old gasket.

NOTE: There are extra bolts in the parts kit. Replace as needed.

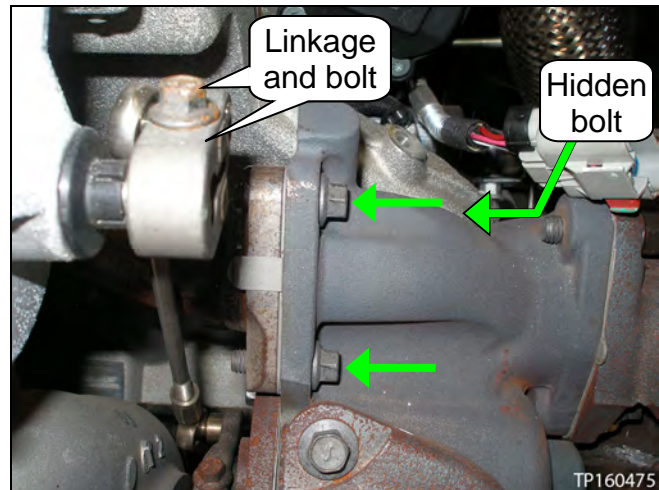

Figure 89

34. Mount and secure the rotary turbine control valve upper linkage (see Figure 89 and 90).

- Bolt torque: 10 N•m (1.0 kg-m, **84 in-lbs**)

35. Connect the EGR valve actuator connector (see Figure 90).

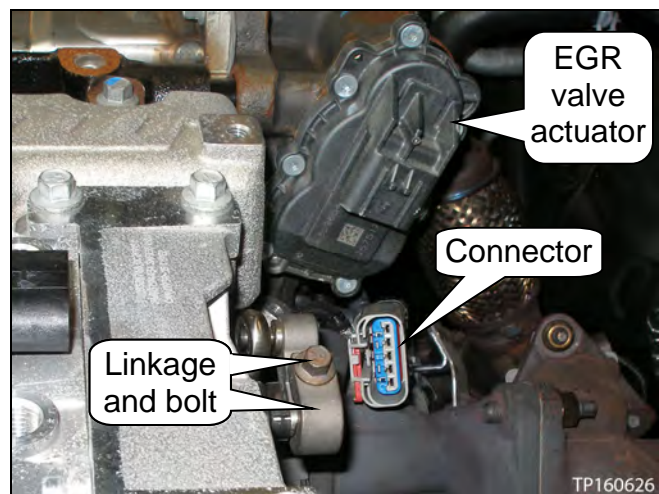

Figure 90

36. Install the exhaust pressure sensor tube (see Figure 91 and 92).

- Replace the O-ring with a new one.
 - Coat the O-ring with P80 Emulsion (see **CAUTION** under **PARTS INFORMATION**).
- Fully insert the tube in the intake manifold first.
- Bolt 1 and 2 torque: 7 N•m (0.7 kg-m, **62 in-lbs**)
- Flare nut torque: 19 N•m (1.9 kg-m, **14 ft-lbs**)

NOTE: The flare nut torque specification is an adjusted value when using a torque wrench 11-15 inches long and a flare nut type “crow’s foot” 1-1.5 inches long.

- The “crow’s foot” is measured from the center of the square hole to the center where the flare nut fits (see Figure 93).



Figure 93

37. Mount the stage 2 fuel filter assembly with the one bolt (see Figure 94).

- At this time, install the bolt finger tight.

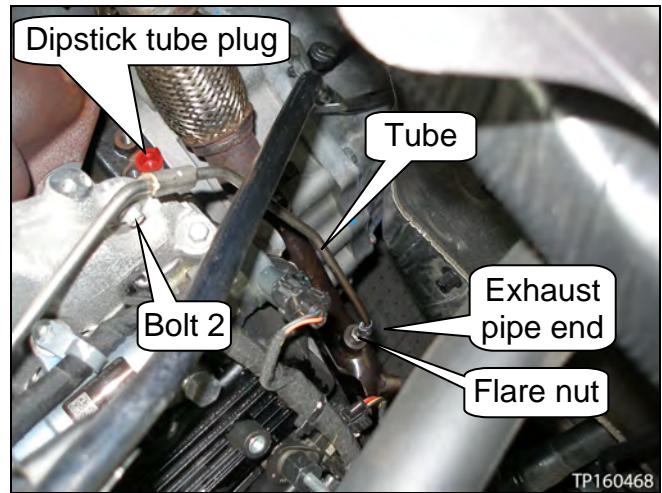

Figure 91

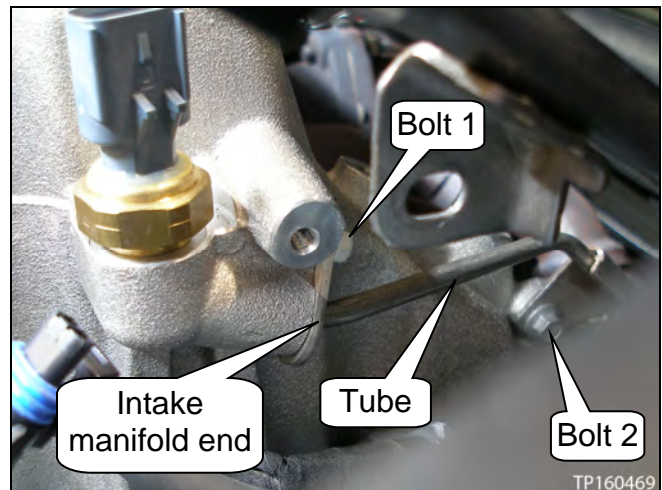

Figure 92

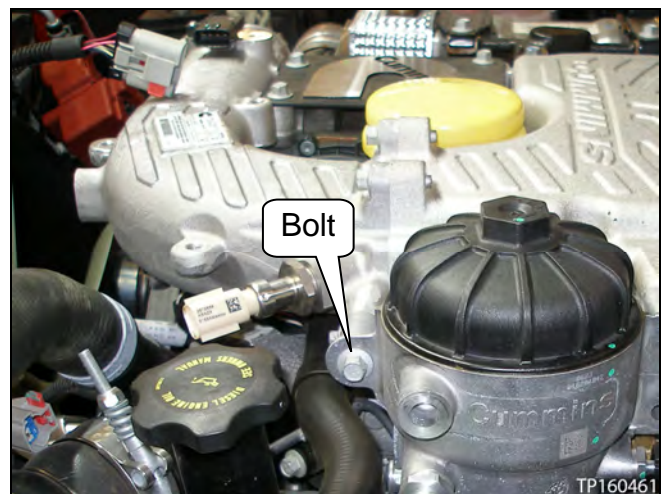

Figure 94

38. Install the oil dipstick with tube.

- a. Remove the plug (see Figure 95).
- b. Install a new O-ring on the oil dipstick tube.
 - Coat the O-ring with engine oil.
- c. Insert the oil dipstick tube into the first engine block hole.
- d. Guide the oil dipstick tube further into the first hole at an angle, and then into the second engine block hole until fully seated (see Figure 95, 96 and 97).
- e. To verify the oil dipstick tube is properly installed, check the engine oil level.

- If the oil level registers the same as recorded on page 12, step 14, the oil dipstick tube is properly installed.
- If NO oil registers, the oil dipstick tube missed the second engine block hole. Remove and correctly install.

CAUTION: The oil dipstick tube goes through the converter housing area before entering the second engine block hole. It is possible to insert the oil dipstick tube in the converter housing area and not the second engine block hole.

- f. When the oil dipstick tube is fitted correctly, install the bolt (see Figure 98).
 - Bolt torque: 7.4 N•m (0.75 kg-m, 65 in-lbs)

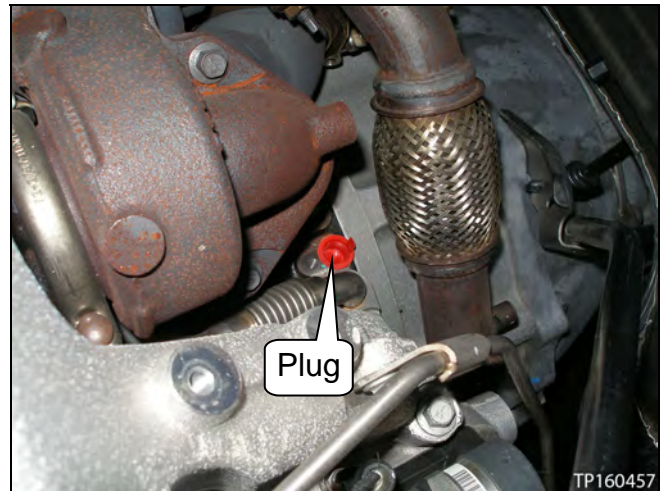

Figure 95

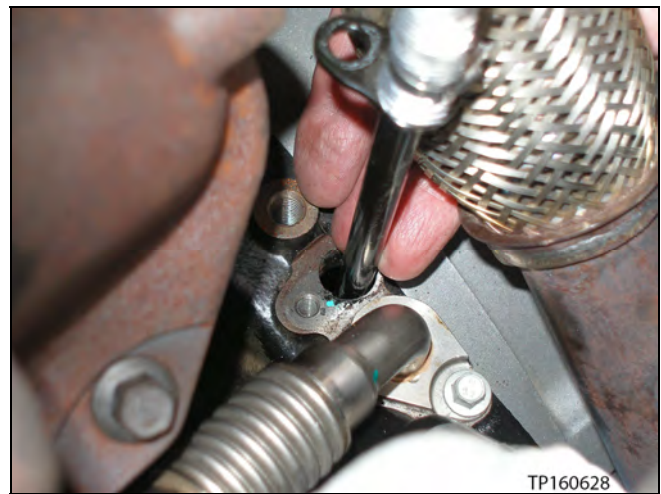

Figure 96

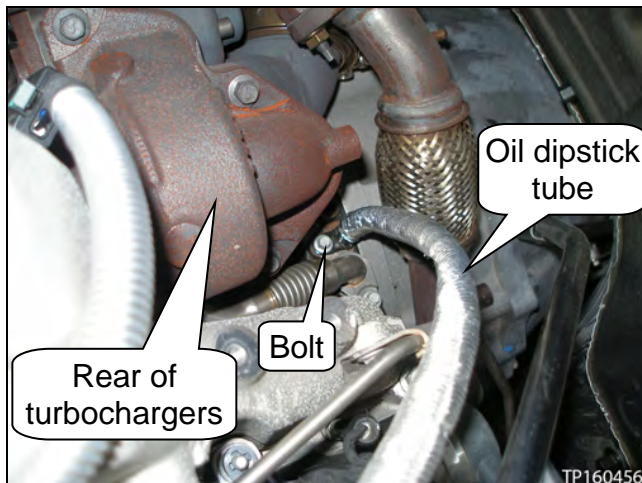

Figure 98

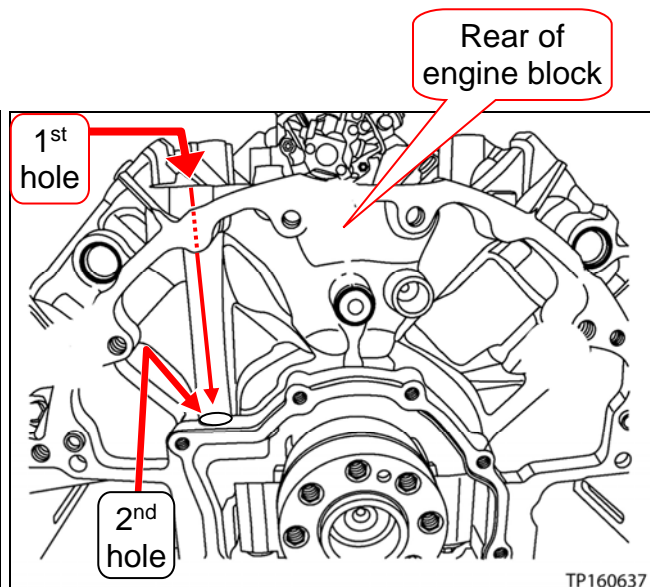

Figure 97

39. Carefully cut, and then remove the tie strap (see Figure 99).

40. Remove the plug and cap, and then connect the fuel line to the stage 2 fuel filter assembly (see Figure 99, 100, and 101).

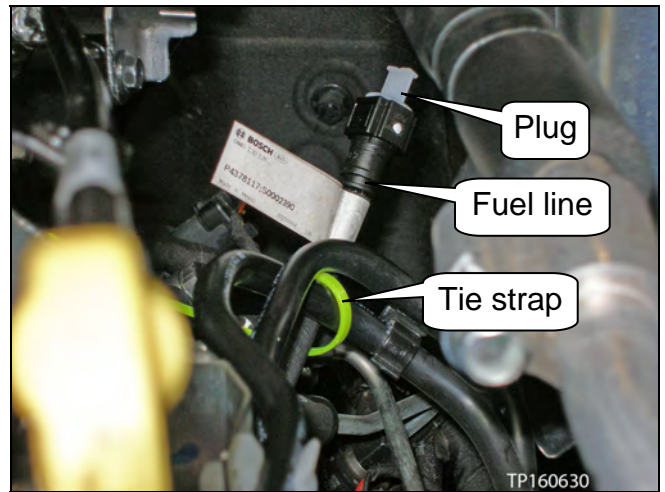

Figure 99

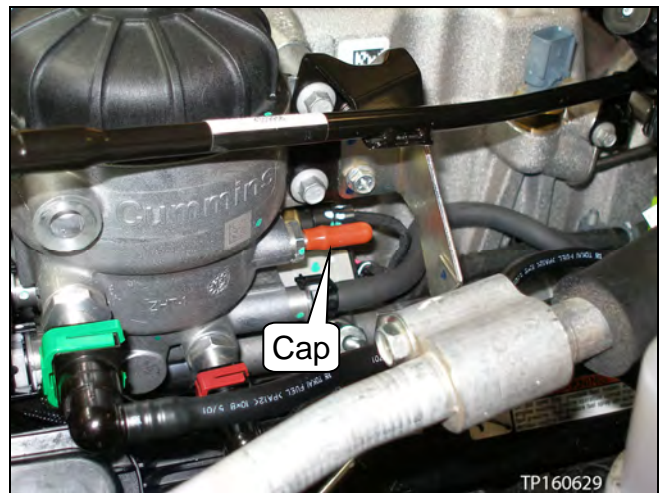

Figure 100

41. Install the four (4) bolts. See Figure 101.

NOTE: Two of the bolts also secure the stage 2 fuel filter assembly.

- Stage 2 fuel filter assembly bolts torque: 18 N•m (1.8 kg-m, **13 ft-lbs**)
 - Also apply the torque above to the bolt shown on page 41, Figure 94.
- Remaining bolts torque: 7.4 N•m (0.75 kg-m, **65 in-lbs**)

42. Snap the two fuel lines in their clips (see Figure 101).

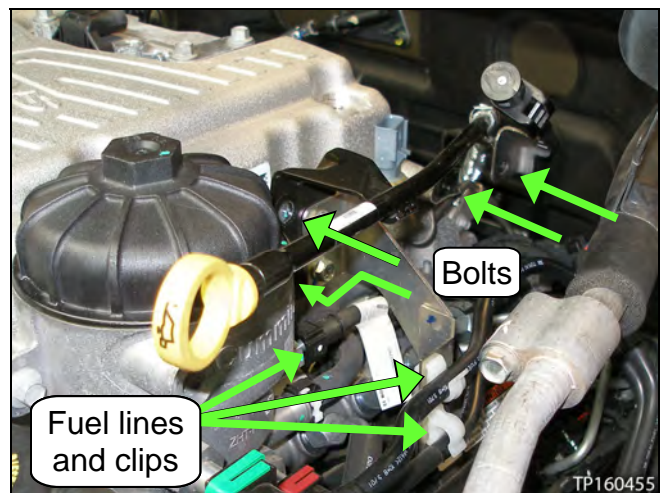

Figure 101

43. Connect the breather tube to the valve cover, and then install the clamp and bolt (see Figure 102).

- Bolt torque: 7.4 N•m (0.75 kg-m, **65 in-lbs**)

44. Route the engine control harness, and then connect and lock all the related connectors (see Figure 103).

- Figures 104-106 shows how to secure the different types of connectors.

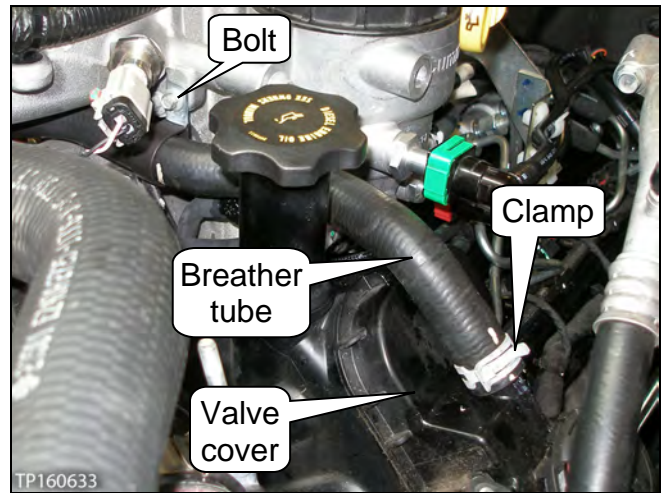

Figure 102

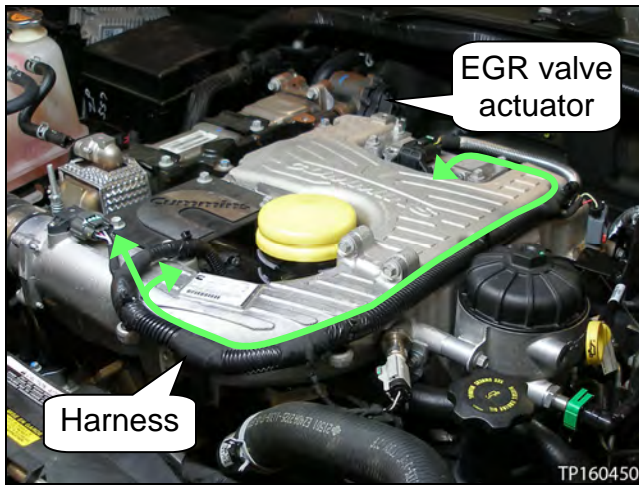

Figure 103

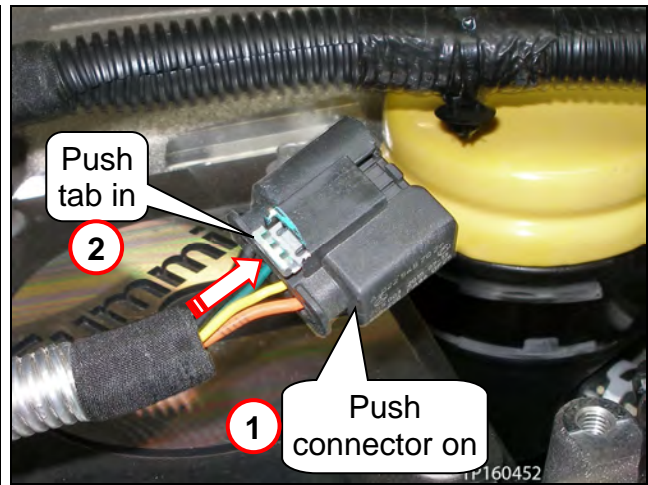

Figure 104

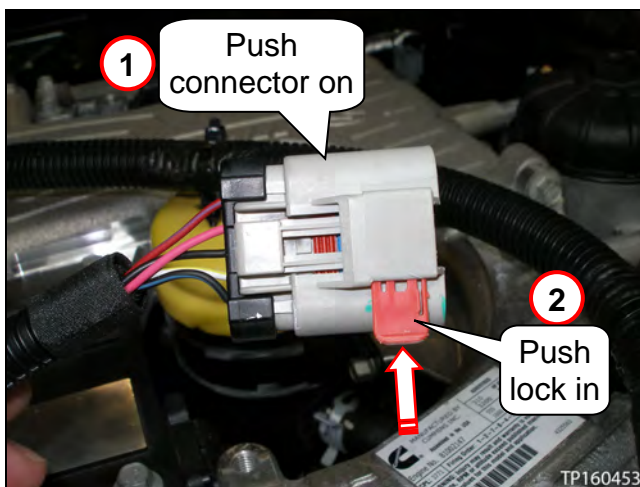

Figure 105



Figure 106

45. Remove the cap, install the air filter element, and then install the air duct with upper air cleaner case (see Figure 107 and 108).
- Make sure to connect the mass air flow sensor and turbocharger compressor intake pressure/temperature sensor.



Figure 107

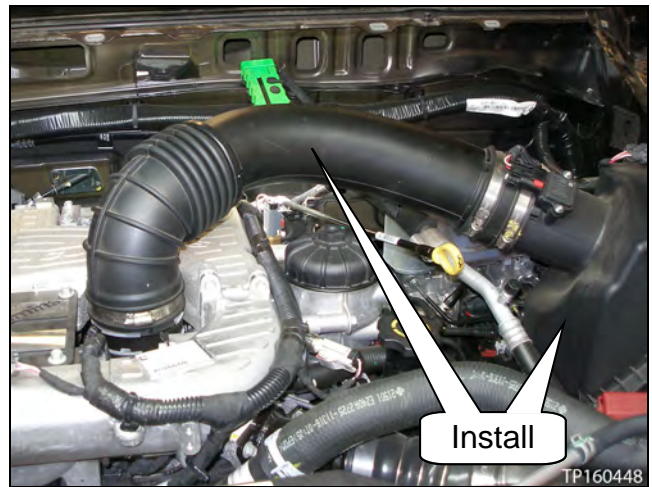

Figure 108

46. Install all three (3) heat shields, center heat shield last (see Figure 109).
- The vehicle will need to be raised to access some of the bolts.
 - Bolts torque: 7.4 N•m (0.75 kg-m, **65 in-lbs**)

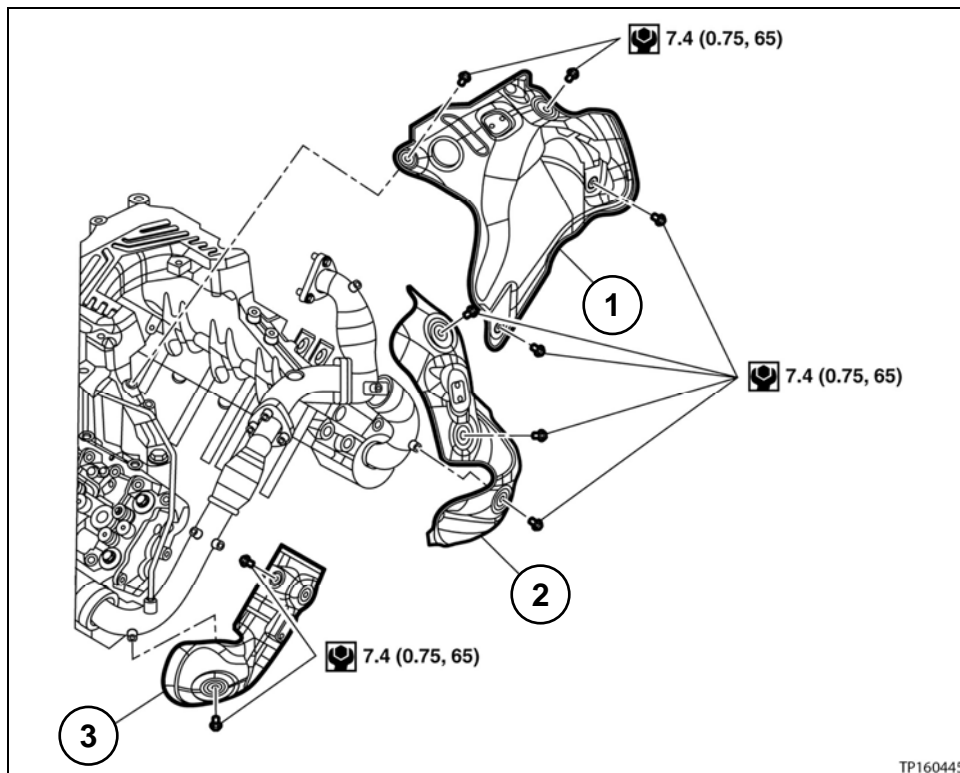

Figure 109

1. Center heat shield

2. RH heat shield

3. LH heat shield

47. Install the cowl.

a. Install the cowl top extension with the eight (8) bolts, and then install both drain pipes (see Figure 110, # 3 & 5, and Figure 112 and 113).

- Bolts torque: 5.5 N•m (0.56 kg-m, **49 in-lbs**)

b. Install the wiper drive assembly (see Figure 111).

- Bolts torque: 5.74 N•m (0.59 kg-m, **51 in-lbs**)
- Torque the bolts in the order shown in Figure 111.

c. Install the cowl top extension bracket (see Figure 110, # 4).

- Bolts torque: 5.5 N•m (0.56 kg-m, **49 in-lbs**)

d. Install the cowl top cover (see Figure 110, # 1).

NOTE: Install the cowl top side trim cover(s) separately as needed (see Figure 110, # 2).

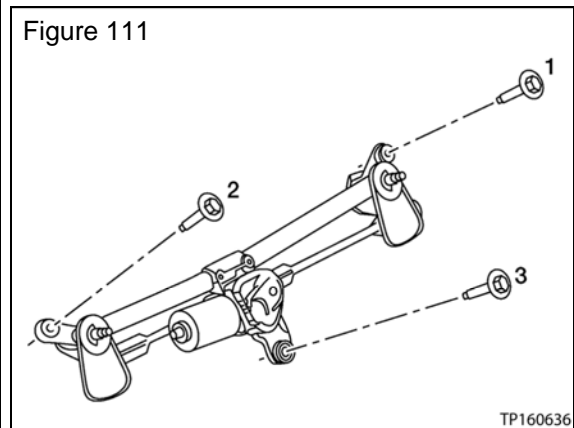
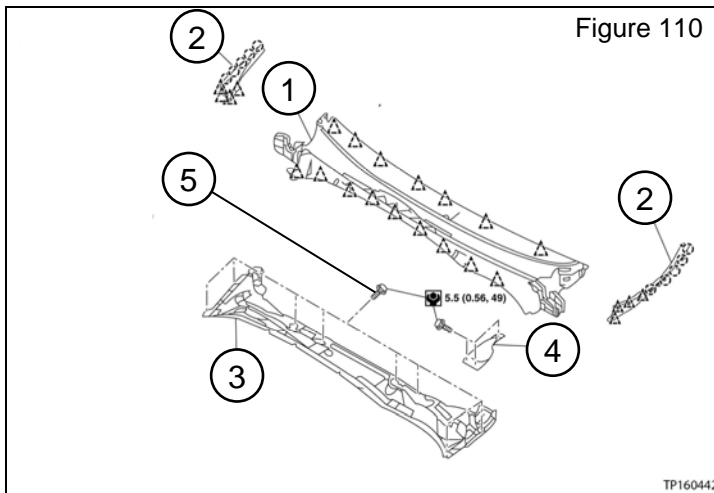

1. Cowl top cover 2. Cowl top side trim cover 3. Cowl top extension
4. Cowl top extension bracket 5. Cowl top extension bracket bolts

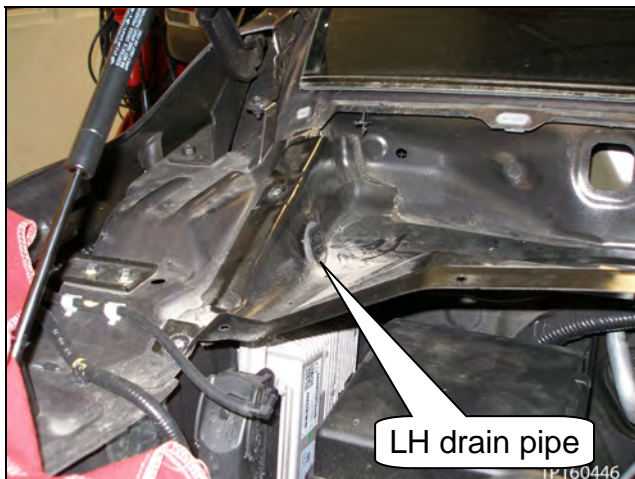

Figure 112

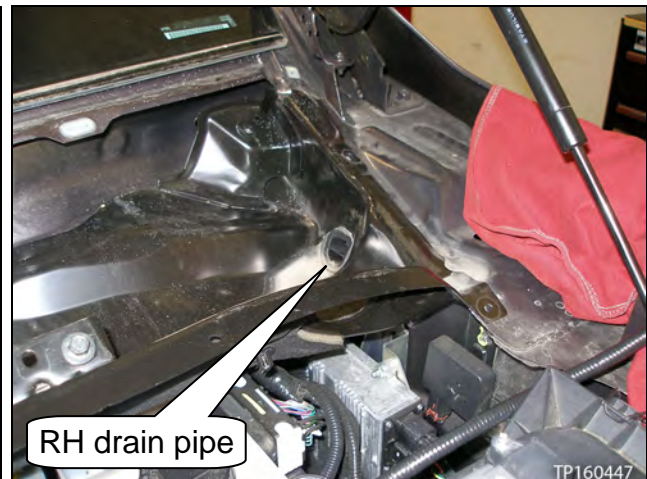

Figure 113

e. Connect the washer nozzle supply hose (see Figure 114).

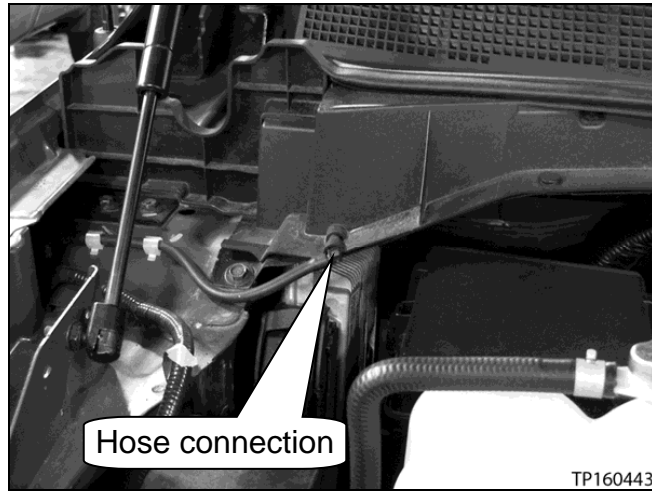

Figure 114

f. Install the wiper arms with nuts and covers (see Figure 115).

- Nuts torque: 23.6 N•m (2.4 kg-m, **17 ft-lbs**)

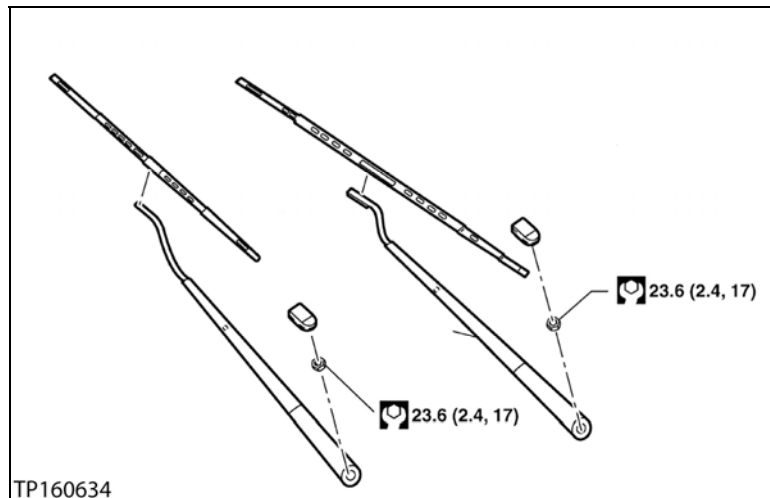

Figure 115

48. Connect the reservoir tank coolant line (see Figure 116).



Figure 116

49. Change the engine oil and filter now.

50. Install the engine under cover (see Figure 117).

51. Connect all battery cables, both positive cables first.

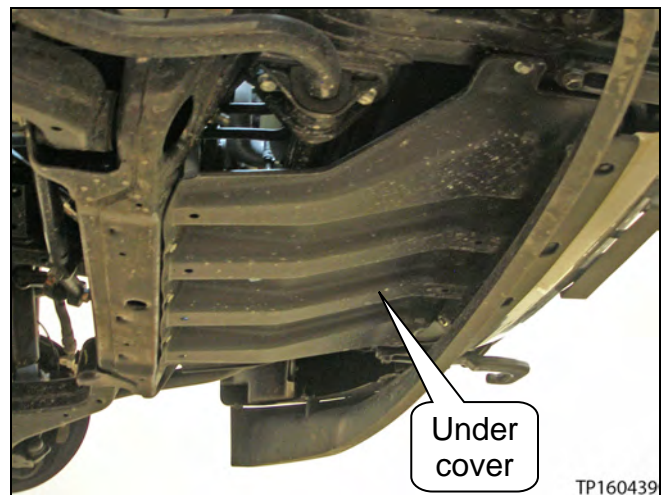

Figure 117

52. Fill (prime) the primary fuel system.

- a. Turn the ignition ON, but do not start the engine.
- b. Wait for the primary fuel pump to stop running, and then turn the ignition OFF.
- c. Repeat step **a** and **b** a second time.
 - Check for fuel leaks.

53. Fill the cooling system.

- a. Set the heater controls to the full HOT and heater ON positions.
 - Turn the ignition ON with the engine OFF as necessary to activate the heater mode.
- b. Fill the cooling system with the coolant drained earlier.
 - Use Coolant Refill Tool J-45695-A, follow the tool's instructions.
- c. Remove Tool J-45695-A and top off the cooling system with coolant as necessary.
- d. Start and run the engine until it reaches normal operating temperature.

CAUTION: Do not allow the engine to exceed normal operating temperature or engine damage may occur.

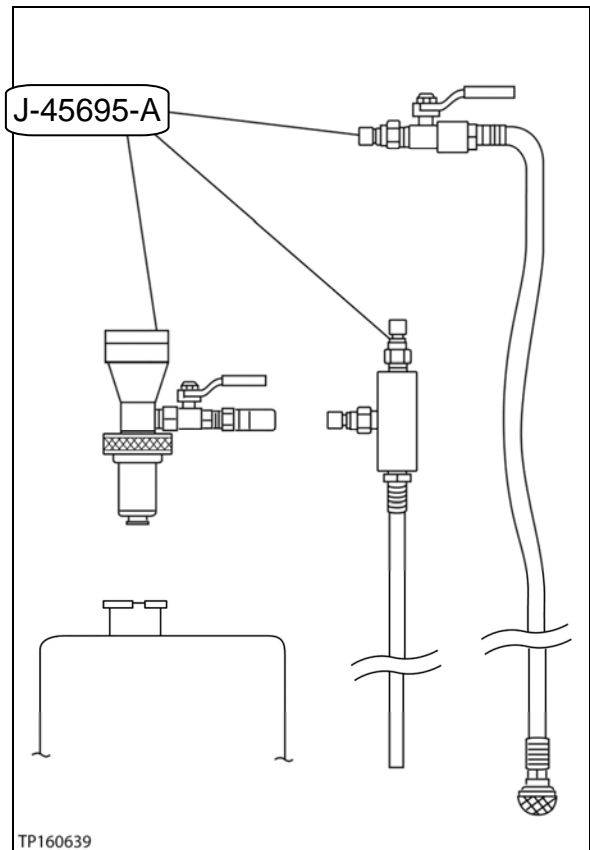

Figure 118

54. Check for fluid leaks (oil/fuel/coolant).

55. Install the tire and wheel assemblies.

- Lug nuts torque: 177 N•m (18 kg-m, **131 ft-lbs**)

56. Perform rotary turbine control valve actuator calibration.

- Refer to page 50, **Calibrate Rotary Turbine Control Valve Actuator.**

57. Reset/initialize electrical systems as needed.

- Refer to the Electronic Service Manual (ESM) section PG-Power Supply, Ground, & Circuit Elements, for a listing of systems that require reset/initialization after reconnecting the 12 V battery.
 - Look in the PG section index for **ADDITIONAL SERVICE WHEN REMOVING BATTERY NEGATIVE TERMINAL.**
 - This list often includes items such as audio, power windows, clock, etc.

Calibrate Rotary Turbine Control Valve Actuator

NOTE: The rotary turbine control valve actuator must be calibrated whenever the rotary turbine control valve linkage is replaced, or dismantled at the UPPER linkage.

CAUTION: The rotary turbine control valve linkage must be replaced IF it is dismantled at the LOWER linkage, or removed completely.

1. Connect the plus VI to the vehicle.
2. Turn the ignition ON with the engine OFF.
 - **The engine must not start or run during the recalibration procedure.**
3. Turn the hazard warning flashers ON.
4. Turn OFF all other vehicle electrical loads such as interior lights, HVAC, blower, rear defogger, audio, NAVI, seat heater, steering wheel heater, etc.
5. Turn ON the CONSULT PC.
6. Select CONSULT-III plus (open C-III plus).
7. Wait for the plus VI to be recognized / connected.
 - The serial number will display when the plus VI is recognized / connected.
8. Select **Diagnosis (All Systems)**.

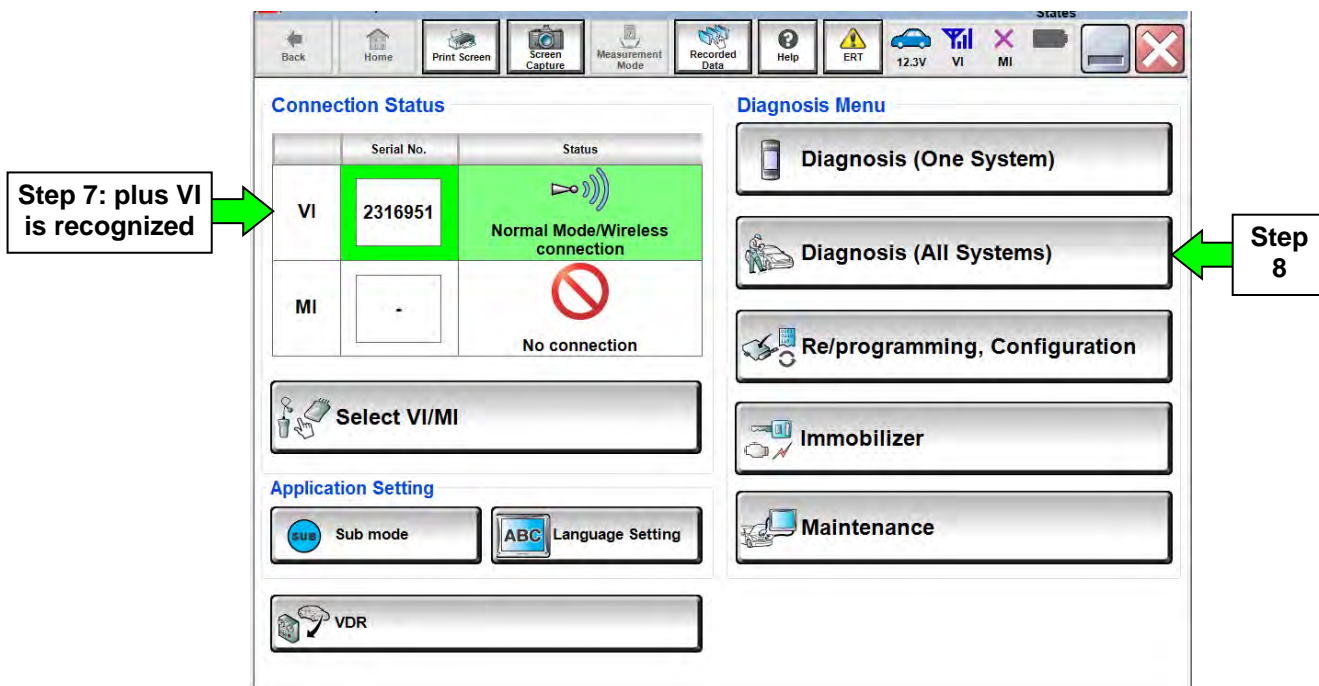

Figure 1C

9. Select **Confirm**.

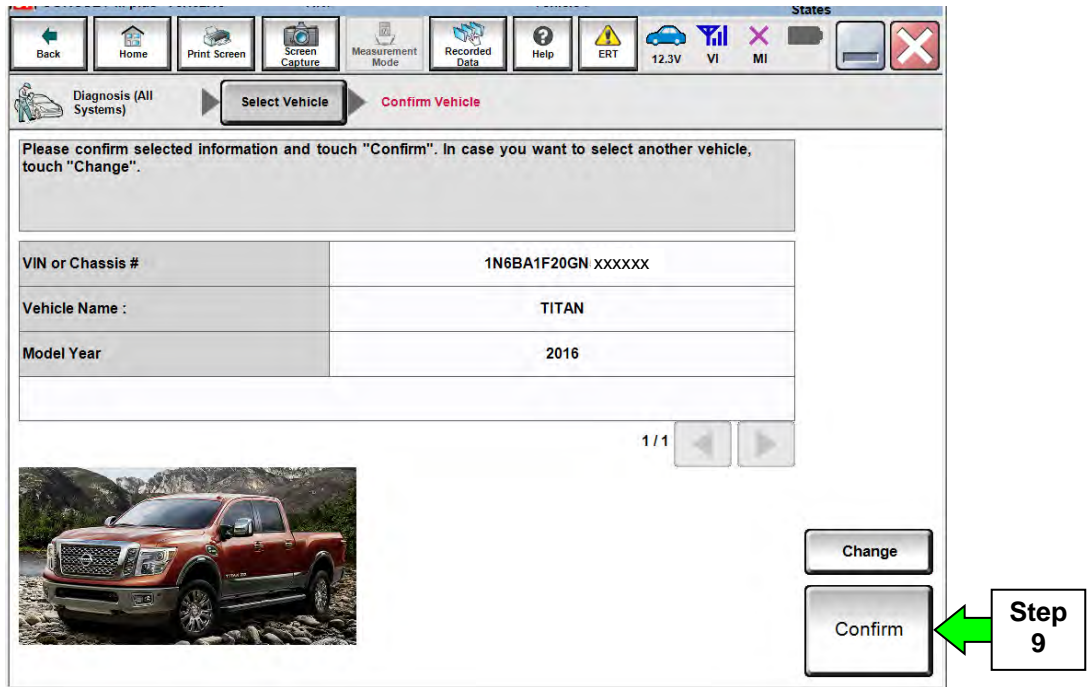

Figure 2C

10. If DTC P2560-00 displays, erase the DTC (select **ERASE**).

- If DTC P2560-00 does not display, go to step 11.

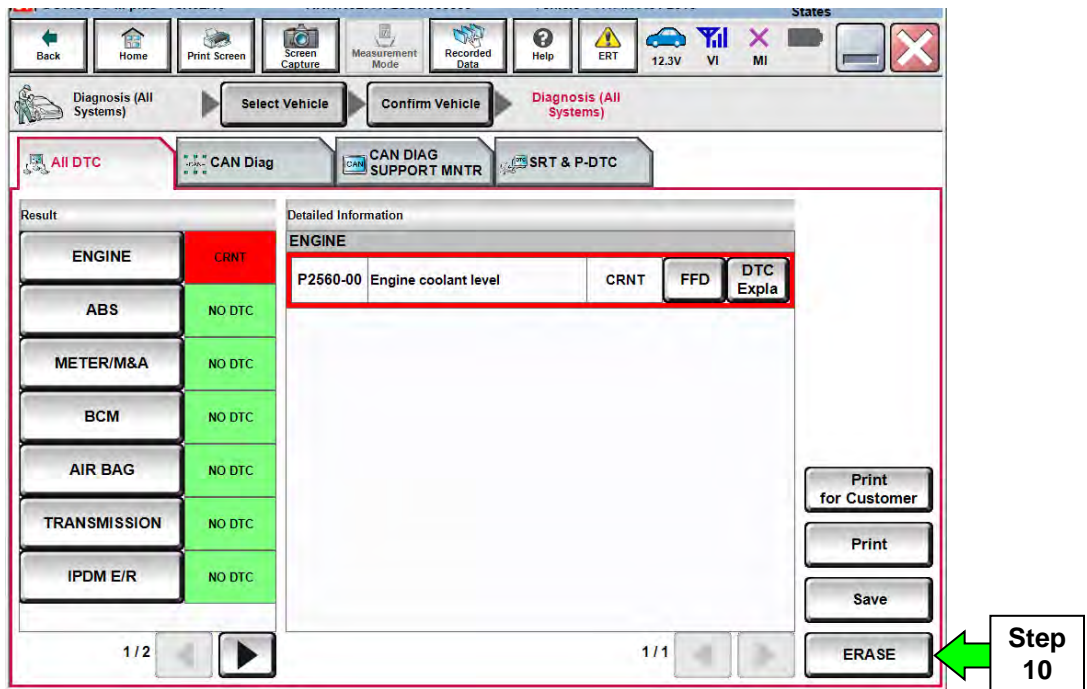

Figure 3C

11. Select **ENGINE**.

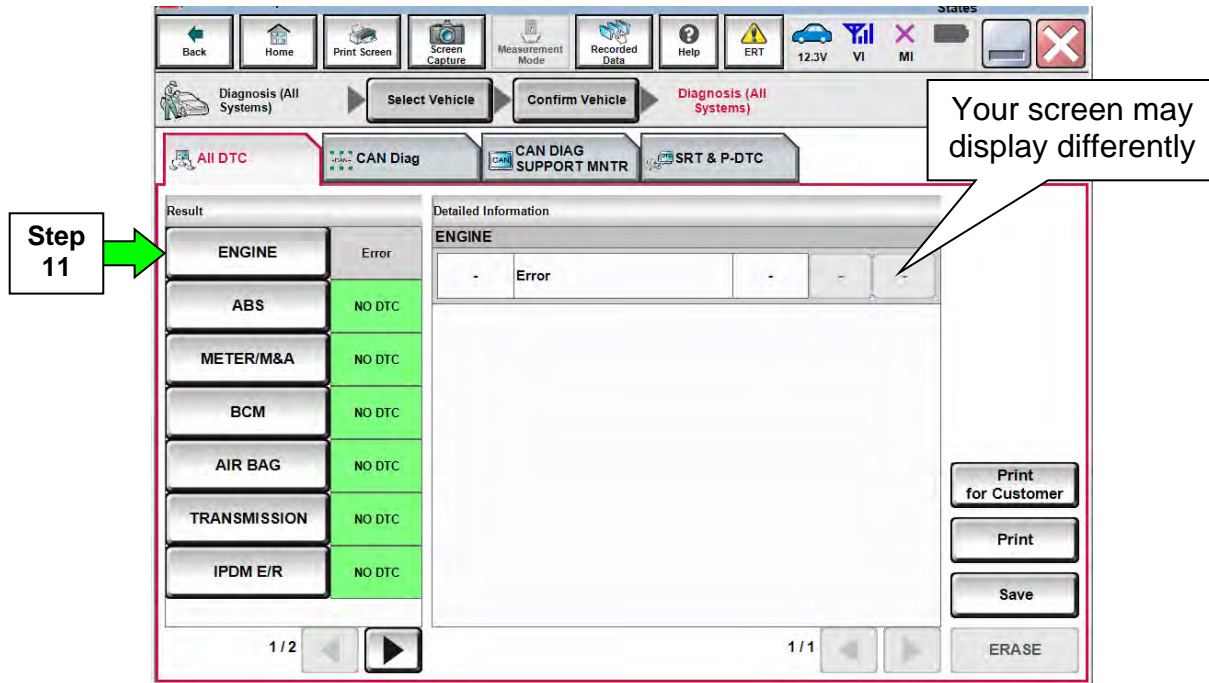

Figure 4C

12. Select the following:

- a. **Work Support**
- b. **RTCV actuator calibrate**
- c. **Start**

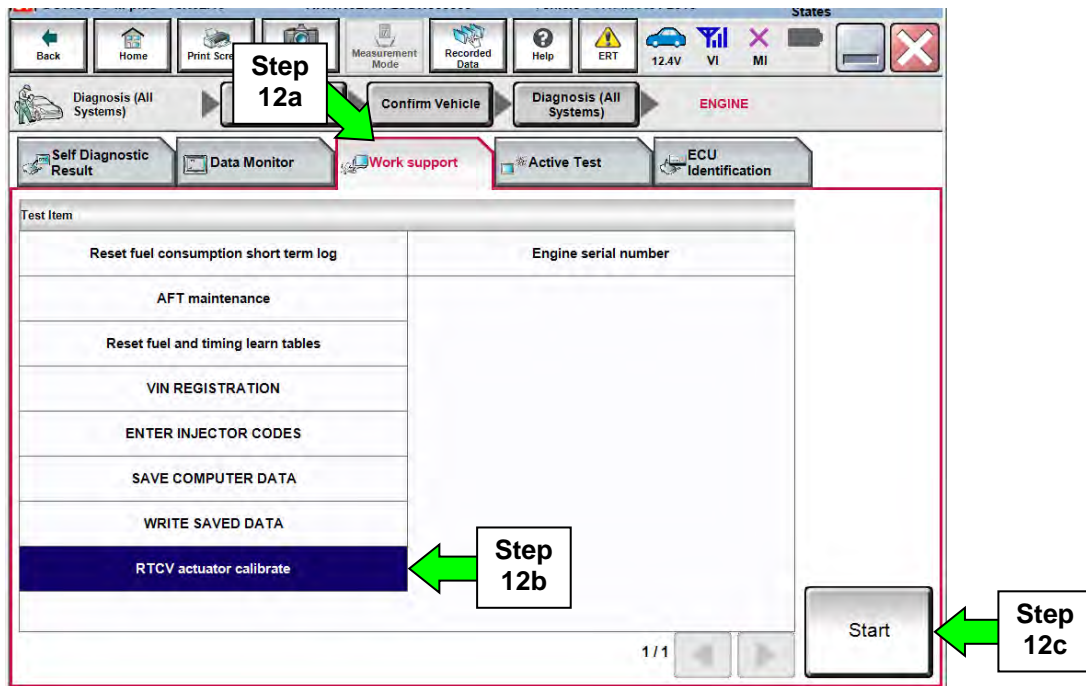

Figure 5C

13. Stand near the engine with the hood open.

14. Select **Calibrate**.

- **DO NOT SELECT “Install”**.
- Listen to the rotary turbine control valve actuator (actuator).
 - During the calibration process, the actuator will make a rattling, clicking type noise.
- When the noise stops, calibration is complete.
NOTE: C-III plus does not give a confirmation notice. Calibration is complete when actuator noise stops.

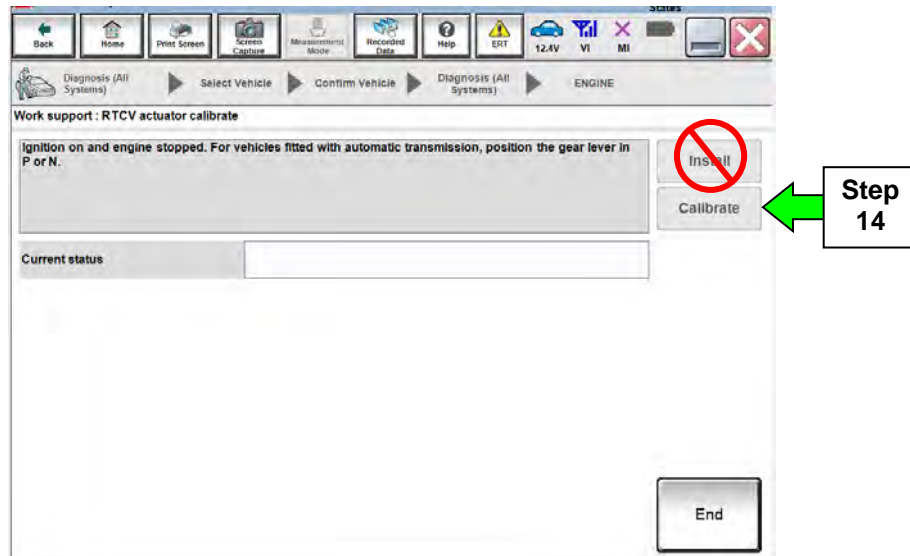

Figure 6C

15. Once calibration is complete, select **End**.

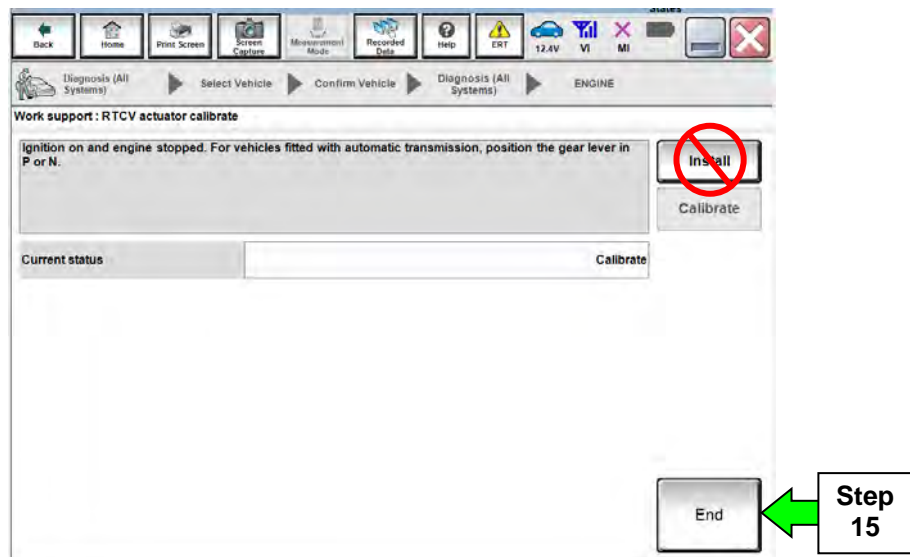

Figure 7C

16. Close C-III plus.

17. Turn the ignition OFF.

18. Disconnect the plus VI from the vehicle.

PARTS INFORMATION

DESCRIPTION	PART NUMBER	QUANTITY
PARTS KIT-ENG (high pressure turbocharger parts kit)	10007-EZ40A	1
MOBDEV 1300 10W30 GAL (Nissan diesel engine oil)	999GK-10W30DV	10 qts (a) (b)
OIL FILTER	15208-EZ40A	1
P-80 [®] Emulsion	999MP-P80EMUP	1 tube (a) (b)

(a) Nissan MOBDEV 1300 10W30 diesel engine oil and P-80[®] Emulsion are available through the Nissan Maintenance Advantage program: Phone: 877-NIS-NMA1 (877-647-6621). Website order via link on dealer portal www.NNAnet.com and click on the “Maintenance Advantage” link.

- P-80[®] Emulsion is also available through local sources.

(b) For warranty repairs, Nissan MOBDEV 1300 10W30 diesel engine oil must be used and P-80[®] Emulsion must be used on all “air handling system” O-ring seals. For customer pay repairs, Nissan MOBDEV 1300 10W30 diesel engine oil and P-80[®] Emulsion is recommended, but an equivalent engine oil and water based assembly lubricant may be used.

CAUTION: Do not use petroleum based lubricants as they may cause damage to the “air handling system” O-ring seals.



P-80[®] Emulsion

Parts Cross Reference List

The following table lists all individual parts in the high pressure turbocharger parts kit, # **10007-EZ40A**, plus a crossover reference to Cummins' part numbers.

DESCRIPTION	NISSAN P/N	CUMMINS P/N	QTY
High Pressure Turbocharger	- -	- -	1
SEAL-O RING	21049-EZ40C	5266152	2
GASKET-INTAKE MANIFOLD	14035-EZ40A	4976436	8
BOLT	11035-EZ41D	4325254	8
BOLT	11035-EZ43A	4359786	2
GASKET	14038-EZ40A	4325399	1
EGR TUBE GASKET	14722-EZ40B	4325416	1
SEAL-O RING	16569-EZ40A	2835314	1
BOLT	14069-EZ40C	3796378	2
TURBOCHARGER OUTLET GASKET	14445-EZ40A	3779725	1
BOLT	11035-EZ49C	3785556	3
GASKET-EYE BOLT	15189-EZ41A	3094065	2
TURBOCHARGER OIL OUTLET GASKET	15196-EZ40C	4325860	1
BOLT	11035-EZ40D	4325243	2
SEAL-O RING	16569-EZ40D	3779750	2
BOLT	14069-EZ40D	3796377	3
BOLT	11035-EZ43D	4359860	2
GASKET-EYE BOLT	15189-EZ40A	4894721	2
SEAL-O RING	21049-EZ40B	4977258	2
SEAL-O RING	15066-EZ42C	3029820	1
SEAL OIL LEVEL GAUGE GUIDE	15066-EZ41B	3946188	1
SEAL-O RING	15056-EZ40E	4325402	1
High Pressure Turbocharger Speed Sensor O-ring Seal	- -	3787623	1

CLAIMS INFORMATION

Submit a Campaign (CM) line claim using the following claims coding:

CAMPAIGN ("CM") ID	DESCRIPTION	OP CODE	FRT
PC471	Replace High Pressure Turbocharger	PC4711	4.6 hrs

Expense Code

EXPENSE CODE	DESCRIPTION	MAX AMOUNT
201	MOBDEV 1300 10W30	\$36.30

If DTC P0524 is Stored

If DTC P0524 is stored:

- a. Print a copy of DTC P0524 from C-III plus.
- b. Complete the PCC Preauthorization Form in ASIST.
 - See the pre-selection screen on page 57, Figure 119.
- c. Attach the C-III plus copy to the Preauthorization Form.
- d. After submitting the Preauthorization Form with attachment, call the PowerTrain Call Center (PCC) for further instructions at **800-973-9992 (opt 1)**.

NOTE: A repair for this issue is not available at this time. When contacted, the PCC will give additional instructions.

If HP Turbocharger Fails Inspection

If the high pressure turbocharger fails inspection:

- a. Record a continuous video of the area(s) of the HP turbocharger that indicates failed inspection, and the VIN.
 - Use borescope J-51951 if needed (see page 2).
 - Make sure the continuous video has a clear image of the incident area(s) of the failed HP turbocharger, and the VIN on the F.M.V.S.S. certification label (VIN label).
 - The PCC may require a live “Tech Cam” session.
- b. Complete the PCC Preauthorization Form in ASIST.
 - See the pre-selection screen on page 57, Figure 119.
- c. Attach the video to the Preauthorization Form.
- d. After submitting the Preauthorization Form with attached video, call the PCC for further instructions at **800-973-9992 (opt 1)**.

NOTE: A repair for this issue is not available at this time. When contacted, the PCC will give further instructions.

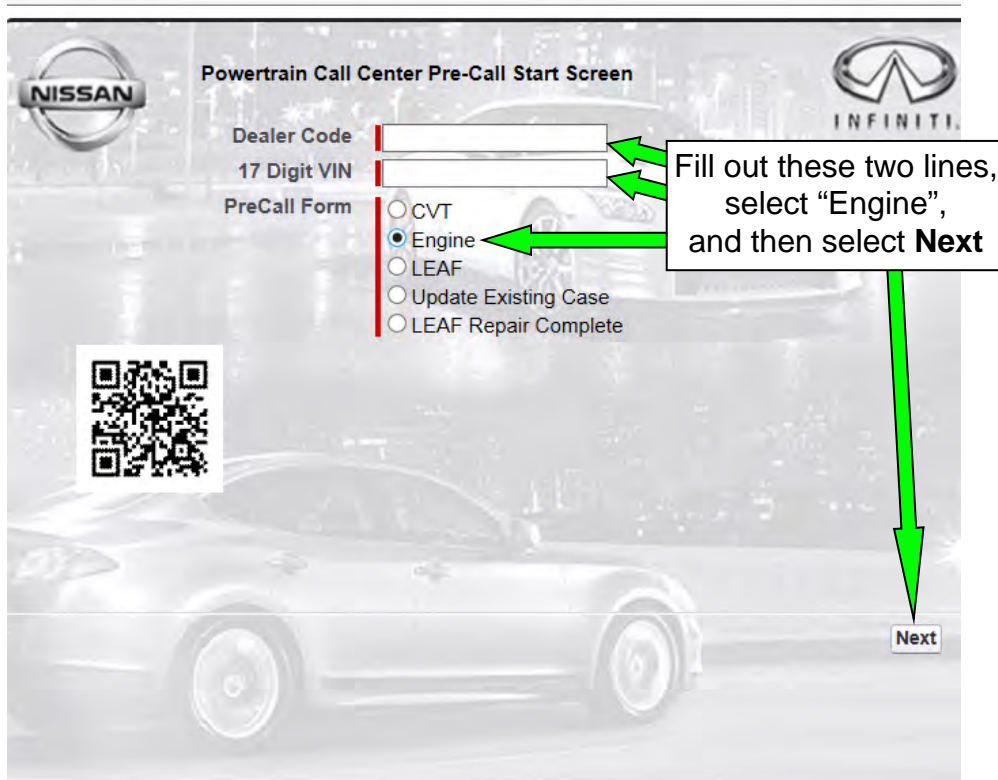

Figure 119