

## Replacement of Zero Radius Grabber Carriage Rollers

**Date:** October 26, 2016  
**Bulletin Name:** ZR-TSIB-011  
**Model:** Zero Radius  
**Model Year:** 2010 to Present

### Purpose:

McNeilus Truck and Manufacturing recommends replacing the Zero Radius grabber carriage rollers with new rollers (P/N 1541824) when one or all of the rollers have worn and need replacing. It is highly recommended that all four rollers are replaced at the same time to ensure the best life and wear of the rollers. Follow the preventive maintenance schedule of daily lubrication of the rollers to ensure best life and wear of the rollers.

### Notice:

- This bulletin should be read and understood in its entirety before performing this procedure.
- All procedures outlined in the bulletin must be performed by skilled service personnel. Refer to the product service manual for descriptions of maintenance procedures.

### SAFETY NOTICE

**Perform your company's Lockout/Tagout procedure. If your company does not have a Lockout/Tagout procedure, follow OSHA 1910.147 and 1910.146 Confined Space as appropriate.**

### Tools and Equipment Required:

- 1/2" drive ratchet
- 5/16" Allen head socket wrench
- 1/4" drive set with a 5/16" socket wrench
- 1/2" electric or air impact wrench (optional)
- 1/2" torque wrench
- Loctite® 262 threadlocker or equivalent

### Parts Required:

Item	Part Number	Description	Qty.
1	1541824	ROLLER, GRABBER, 2.44"	1-4
2	1427860	SCR, CAP, SOC .38-16X1.50 574 ZC	Up to 16
3	0621024	WASH, SPR, SPT .38X.68X.09 ZC	Up to 16

**NOTE:** Four P/N 1427860 and four P/N 0621024 per roller.

## Procedure:

1. Place unit on a flat surface and block truck tires.
2. Lower the grabber carriage to a working level. Ensure the grabber gear is aligned with the rungs on the mast.
3. Place chains around the grabber and hook those chains to a crane. In addition, place a metal saw horse under the grabber carriage for additional support of the grabber carriage (weight of the grabber carriage is approximately 400 lbs.).
  - **NOTE:** Remove and replace each roller one at a time during this procedure.
4. Perform your company's Lockout/Tagout procedure. If your company does not have a Lockout/Tagout procedure, follow OSHA 1910.147 and 1910.146 Confined Space as appropriate.
5. Starting with one roller, use a 1/4" drive set with a 5/16" socket wrench to remove and retain the grease zerk from the roller (Figure 1).

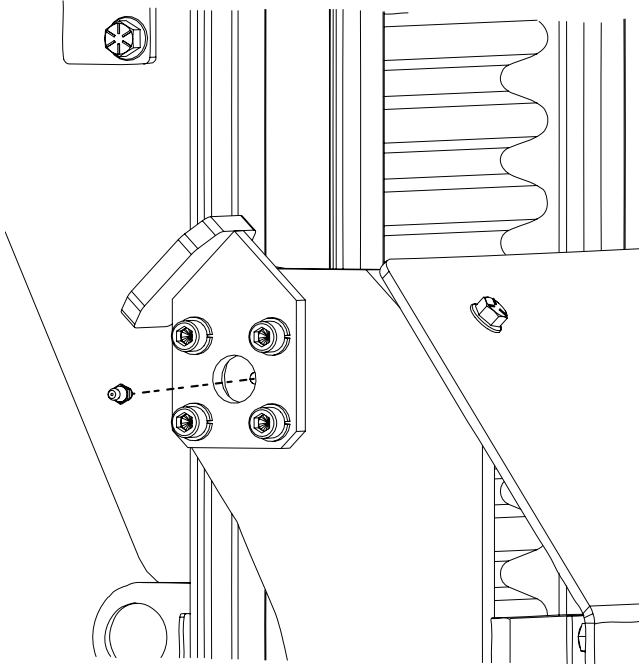

Figure 1

6. Use a 1/2" drive ratchet and a 5/16" Allen head socket wrench to loosen each bolt on that roller (Figure 2).
7. Once the bolts are loose, it is acceptable to use an electric impact or air impact wrench to remove and retain the bolts from that roller.

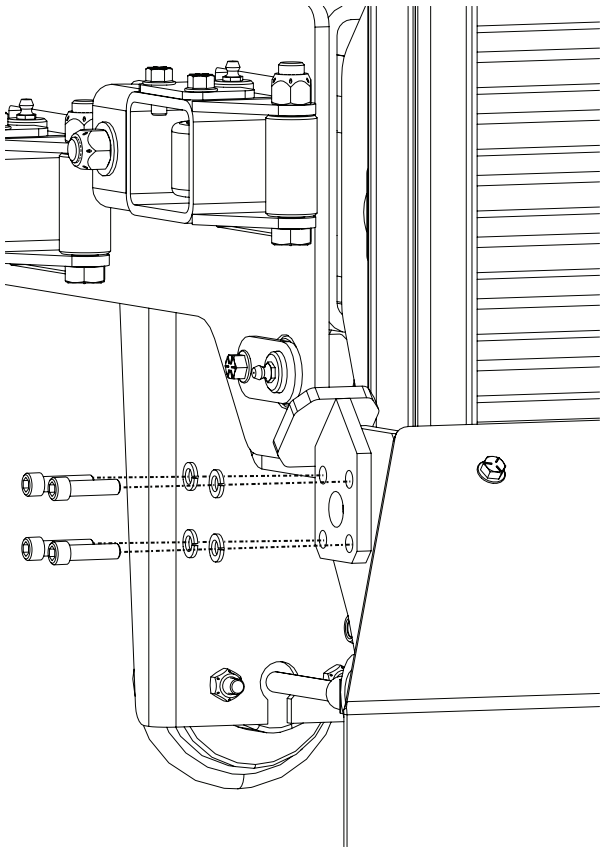

Figure 2

8. Remove and retain the stop bracket (either upper or lower) that secures the roller to the arm (Figure 3). The upper brackets have an angled bump stop; the lower brackets do not.

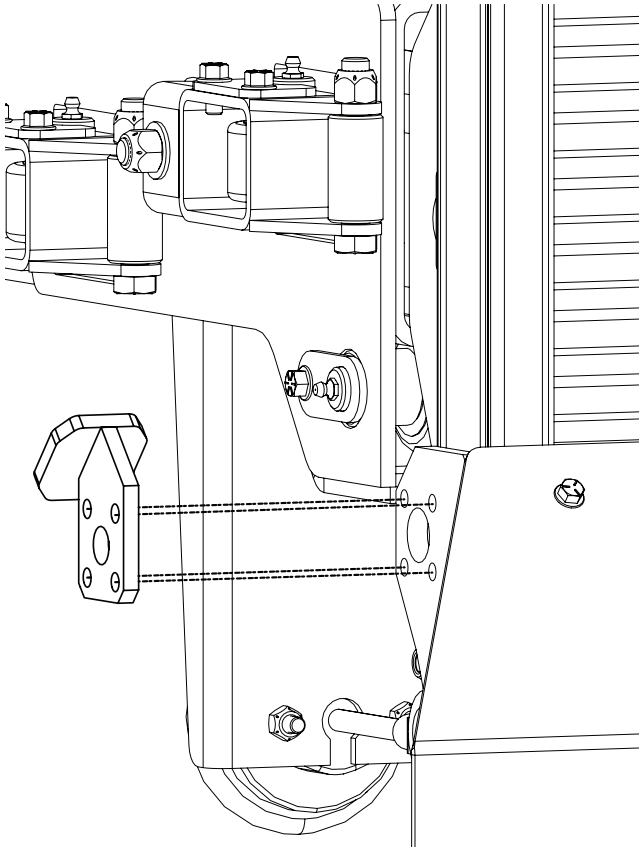

Figure 3

9. Slide the roller and its shim (if used) along the track until you can remove it from the track (Figure 4). Discard both the roller and its shim.

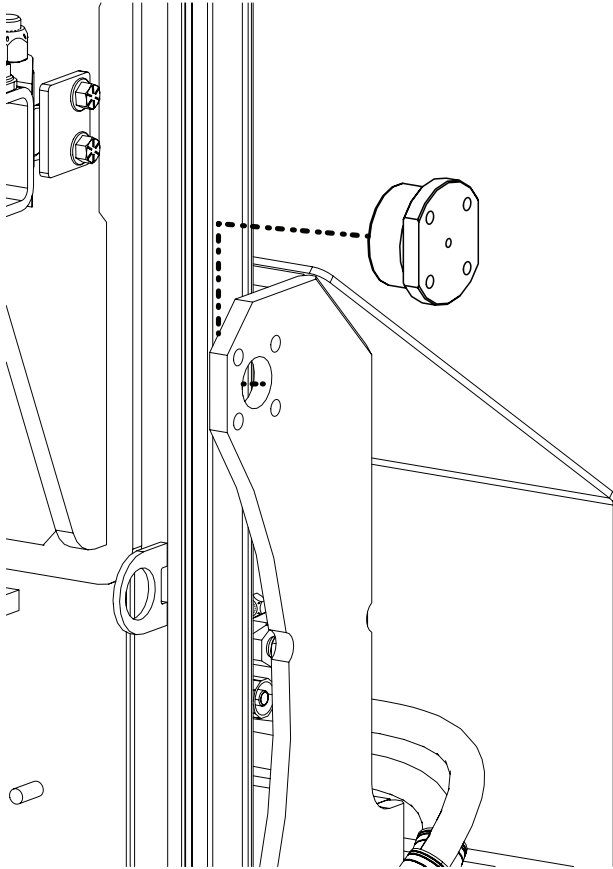

Figure 4

10. Use a 1/4" drive set with a 5/16" socket wrench to remove and retain the grease zerk from the **new roller (PN 1541824)** (Figure 5).

**NOTE:** The part number for the new roller is stamped on the new roller.

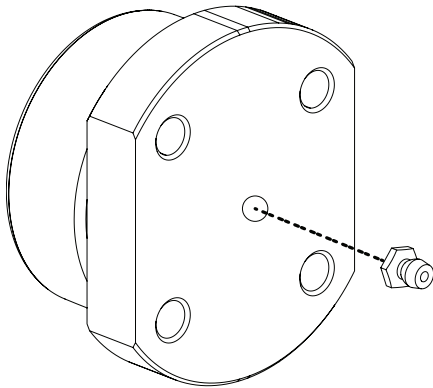

Figure 5

11. Apply a couple of drops of Loctite® 263 threadlocker or equivalent to the new bolts and new lock washers.

12. Insert the new roller (PN 1541824) into the track and slide into position (Figure 6).

13. Align the bolt holes of the roller to the bolt holes on the grabber assembly.

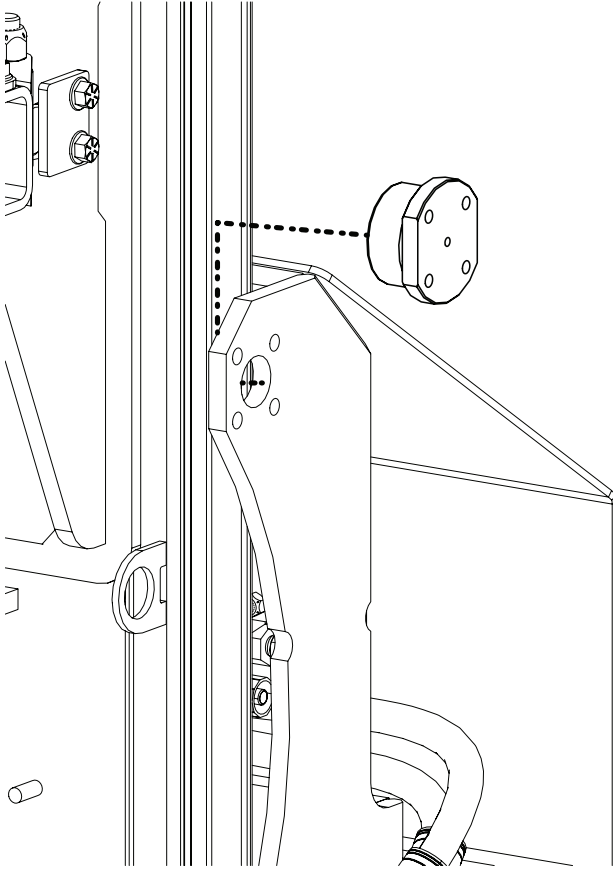

Figure 6

14. Reinstall the stop bracket (Figure 7).

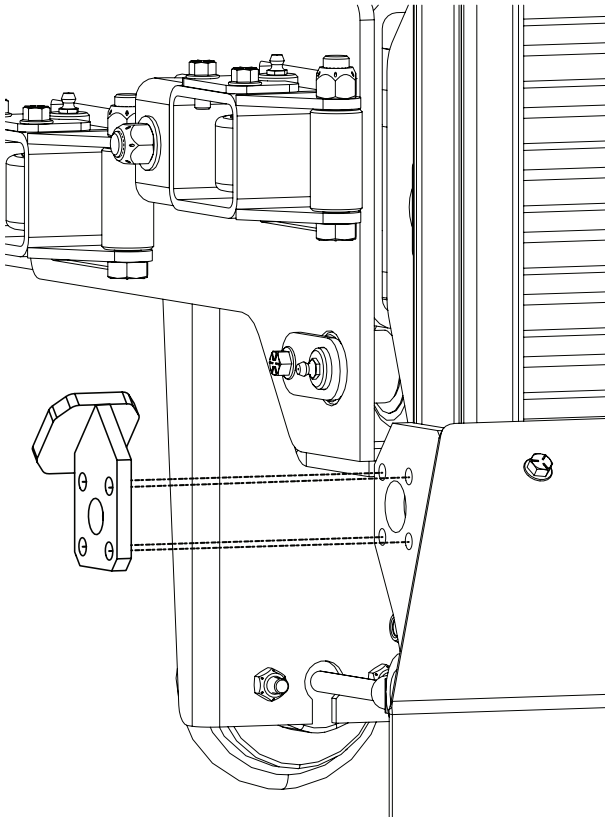

Figure 7

15. Install the new bolt with a lock washer through the stop bracket into the roller (Figure 8). It may be necessary to adjust the parts to get the bolt through the holes to the roller and it may be necessary to use an extension and a 9/16" socket to get the bolts started.

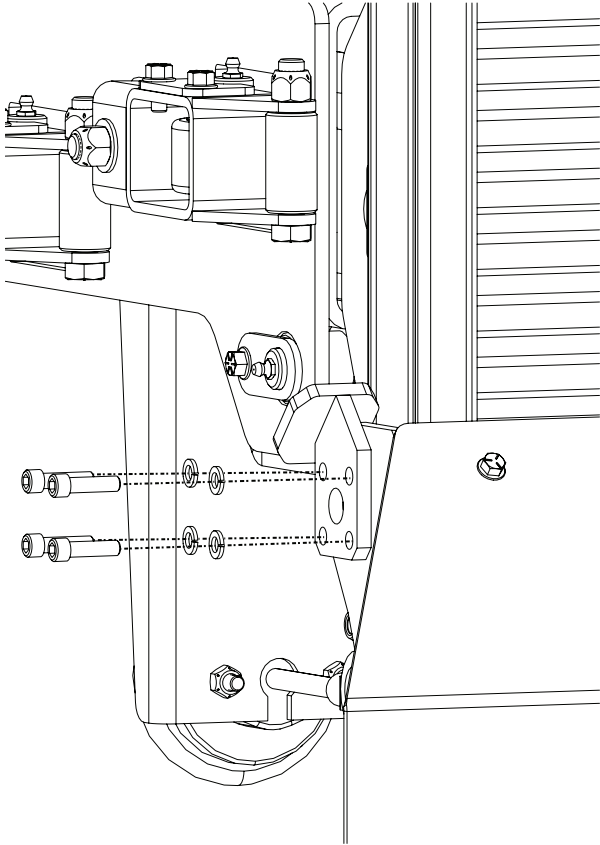

Figure 8

16. Repeat with each bolt and lock washer for a total of four bolts on that roller.
17. Use an impact wrench to snug the bolts, but do not over-tighten.
18. Use a 1/2" torque wrench to torque each bolt to 38 ft.-lbs.
19. Reinstall the grease zerk in the roller using a 1/4" drive set with a 5/16" socket wrench (Figure 9). The grease zerk in the new roller does not require greasing at this time. Grease after the first 10 hours of use and then according to the preventive maintenance schedule located in the operator's or service manuals (daily greasing).

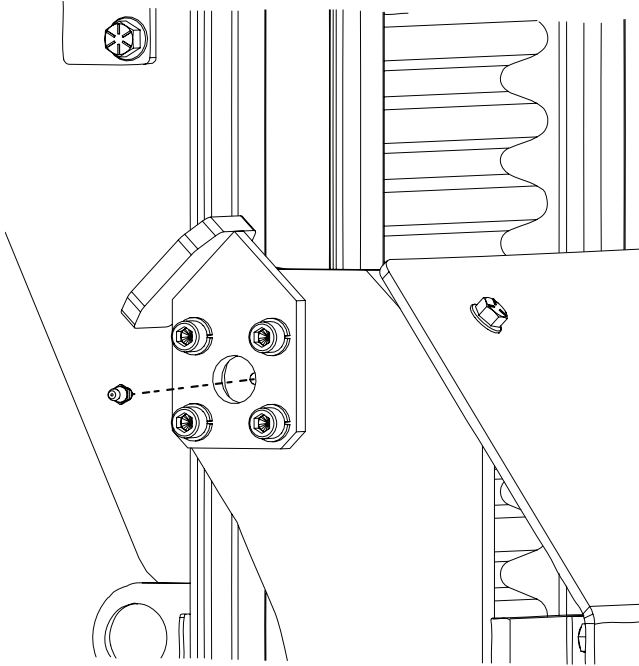

Figure 9

20. Repeat steps 5-19 for the remaining three rollers, **replacing each roller, one at a time.**

- **NOTE:** The roller located at the top of the grabber carriage toward the rear of the truck is installed with a proximity switch flag. This flag must be removed from the old roller and reinstalled when the new roller is installed. The flag should be installed on the outside of the stop bracket and bolted on using the new hardware.

21. Procedure is complete.

22. Remove your company's Lockout/Tagout per your company's procedure. If your company does not have a Lockout/Tagout procedure, follow OSHA 1910.147 and 1910.146 Confined Space as appropriate.

### Continuous Improvement:

The change included in this bulletin is part of the McNeilus® Continuous Improvement Process.

*McNeilus® Company's quality policy is Providing Customer Satisfaction through Innovative Products, Dedicated Service, and a constant focus on Continuous Improvement.*

***"The Customer is our Boss!"***



(888) 686-7278

[www.streetsmartparts.com](http://www.streetsmartparts.com)