

QUARANTINE NOTICE

Reference number:	QN-08-0042	Issued: 24 November 2016
Subject:	Fluid Leakage from the Clutch Slave Cylinder	
Model(s):	V8, V12 Vantage, GT8 and GT12, ASM Transmission only	
VIN range:	Refer to separately published VIN list	
Applicable to:	All Dealers	
Distribute to:	After Sales Manager Executive Manager Service Manager Sales Manager	Warranty Staff Technician(s) Parts Staff

Note: *This repair is the same as Service Action SA-08-0263. Use this Quarantine Notice for vehicles that are not registered and have not been given to a Customer.*

Some vehicles in the affected VIN list for this Quarantine may now be registered and given to a Customer. Make sure that you do a check of the Online Dealer Warranty (ODW) database to make sure that all necessary work is done to every vehicle.

Reason for this Quarantine Notice

There is a small quantity of V8 and V12 Vantage and GT12 ASM transmission vehicles that can have a problem with the fluid connections on the clutch slave cylinder. It is possible that the connectors are not correctly tightened and fluid can leak.

Please do the workshop procedure that follows to examine each of the vehicles in the list of affected VINs and if necessary, tighten the slave cylinder fluid connections. If you find a vehicle that has fluid leakage, please refer to Steps 2, 10 and 21 of Part C and send us a photo of the affected clutch slave cylinder and its batch number.

Workshop Procedure

This Workshop Procedure has the parts that follow:

Part A – Examine the clutch slave cylinder for leaks – V8 Vantage only

Part B – Examine the clutch slave cylinder for leaks – V12 Vantage and GT12 only

Part C – If necessary, tighten the fluid connectors on the clutch slave cylinder

Part A – Examine the clutch slave cylinder for leaks – V8 Vantage only

1. Lift the vehicle and make it safe.

2. Remove the two screws that attach the cover plate to the engine adjacent to the flywheel housing (refer to Figure 1).

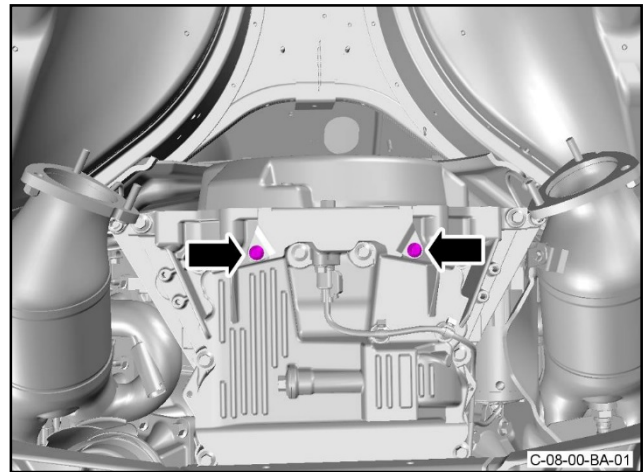

Figure 1

3. Remove the cover plate (refer to Figure 2).

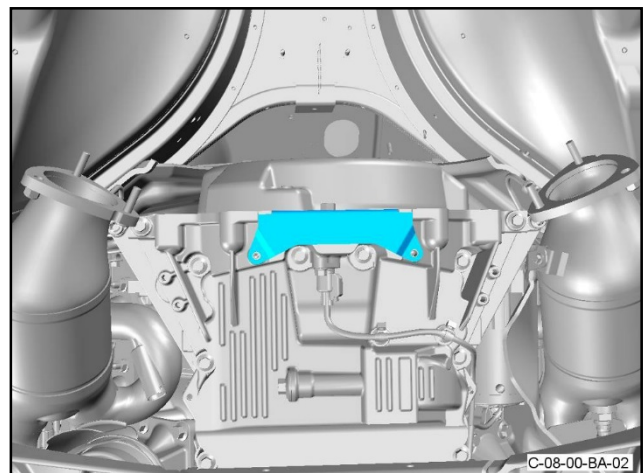

Figure 2

4. Examine the interior of the clutch housing for fluid leaks.

WARNING: HYDRAULIC FLUID IS POISONOUS. DO NOT DRINK HYDRAULIC FLUID OR LET IT TOUCH YOUR SKIN OR EYES. IF YOU GET HYDRAULIC FLUID IN YOUR MOUTH, GET MEDICAL AID IMMEDIATELY.

5. If there are signs of fluid leakage, continue from Part C.
6. If there are no signs of fluid leakage, put the cover plate back into position.
7. Install and torque the two screws that attach the cover plate to 9 Nm.

Part B – Examine the clutch slave cylinder for leaks – V12 Vantage and GT12 only

1. Lift the vehicle and make it safe.
2. Put the tip of an endoscope through the pipe openings in the side of the flywheel housing.
3. Use the endoscope to carefully examine the pipe connections and the interior of the flywheel housing for signs of fluid leakage.
4. If there are no signs of fluid leakage, remove the endoscope. No other work is necessary.
5. If you found signs of fluid leakage, continue from Part C.

Part C – If necessary, tighten the fluid connectors on the clutch slave cylinder

1. Remove the torque tube assembly to get access to the clutch slave cylinder (refer to Workshop Manual procedure 05.01.CB).
2. Take a photograph that clearly shows the clutch slave cylinder and the fluid leakage.
3. Remove the spring clip that attaches the fluid supply pipe to the slave cylinder (refer to Figure 3).
4. Disconnect the fluid supply pipe from the slave cylinder.

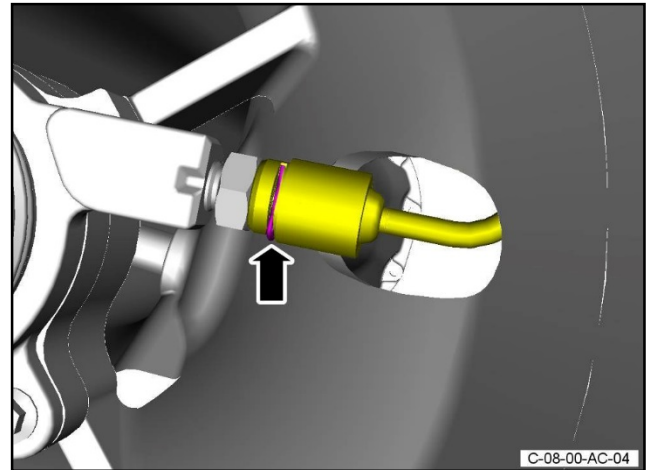

Figure 3

5. Remove the spring clip that attaches the bleed pipe to the slave cylinder (refer to Figure 4)
6. Disconnect the bleed pipe.

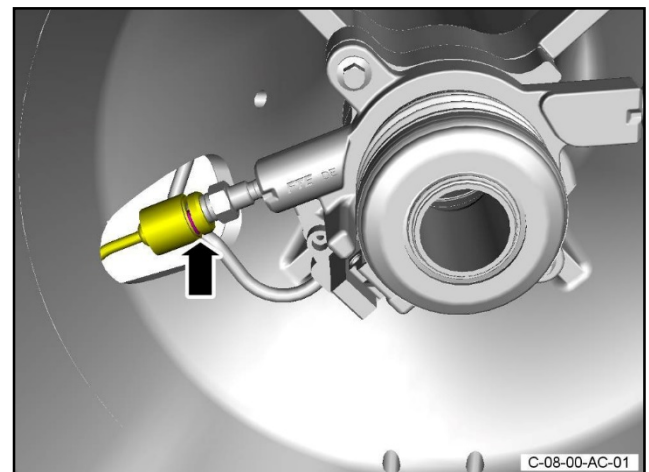

Figure 4

7. Remove the bleed pipe (refer to Figure 5).

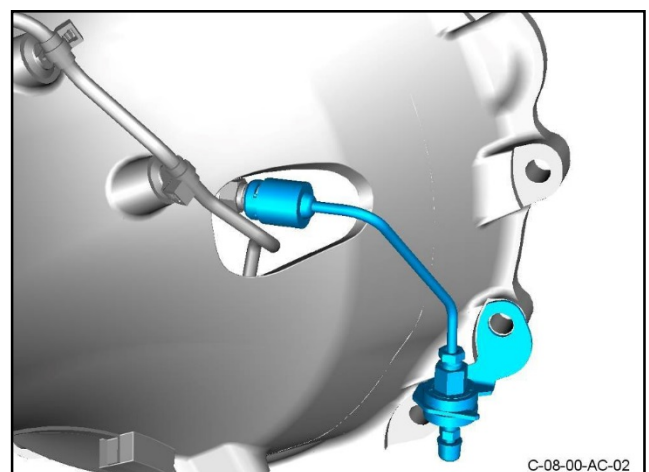

Figure 5

- 8. Torque the fluid pressure connector (1) to 17.5 Nm (refer to Figure 6).
- 9. Torque the fluid bleed connector (2) to 7.5 Nm.

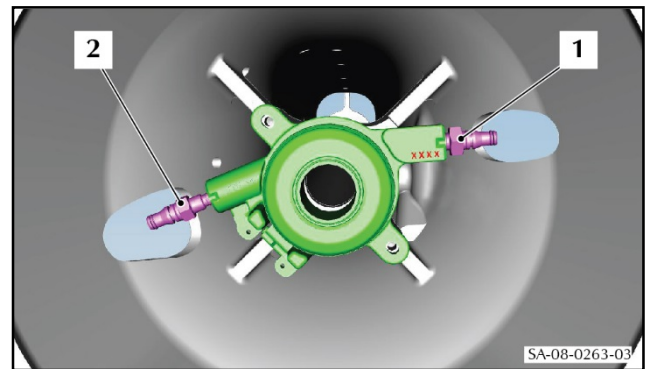

Figure 6

- 10. Record the batch number (1) of the slave cylinder (refer to Figure 7).
Please tell us the batch number when you make the Warranty claim (refer to Warranty Data).

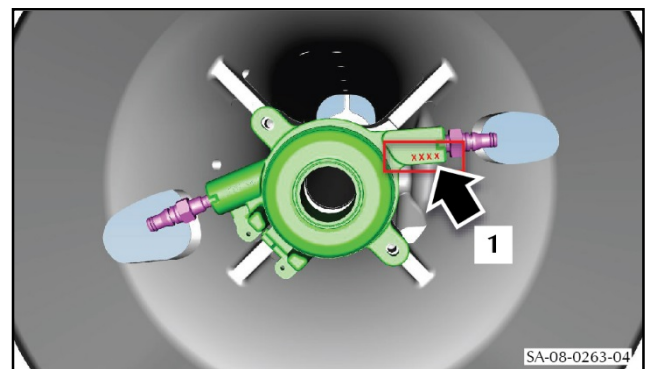

Figure 7

- 11. Clean all leaked fluid from the inside of the clutch housing and the slave cylinder.
- 12. Put the bleed pipe into position (refer to Figure 8).

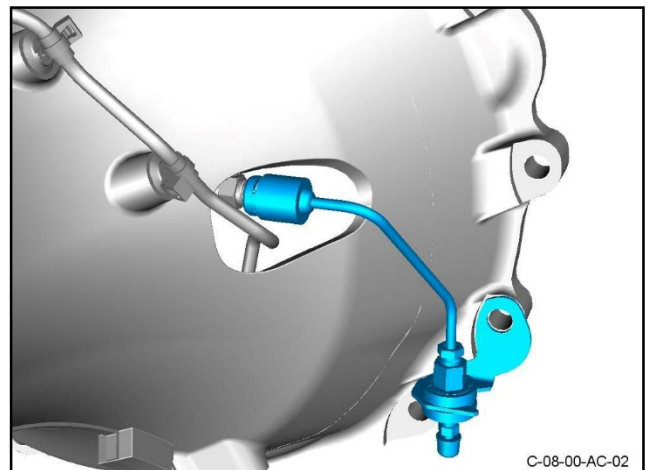

Figure 8

13. Install the spring clip that attaches the bleed pipe to the slave cylinder (refer to Figure 9).

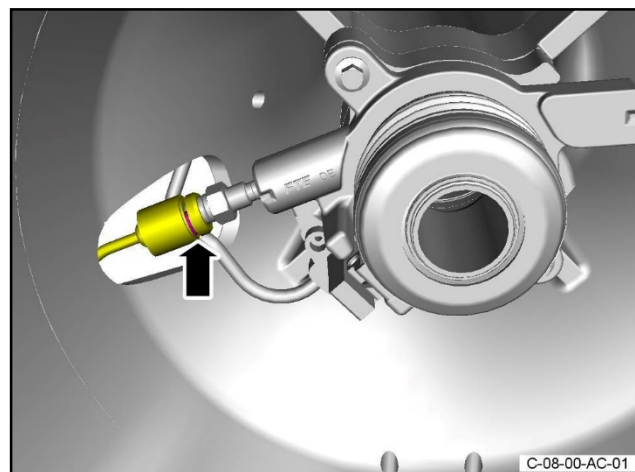

Figure 9

14. Connect the fluid supply pipe to the slave cylinder (refer to Figure 10).
15. Install the spring clip that attaches the fluid supply pipe to the slave cylinder.

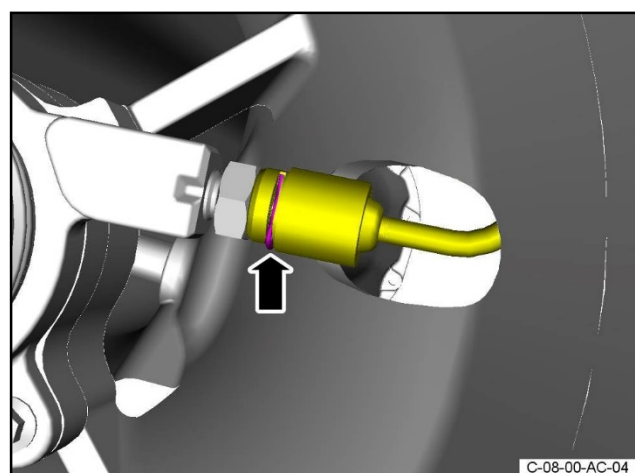

Figure 10

16. Remove the clutch assembly from the flywheel (refer to the applicable steps of Workshop Manual procedure 08.00.BA).

Note: *It is not necessary to remove the flywheel.*

17. Examine the clutch assembly for signs of contamination from fluid. If the clutch is contaminated by fluid, email askamtech@astonmartin.com to get a Warranty Authorisation to replace the clutch.
18. Clean the surface of the flywheel.
19. If Client Services tell you to do so, install a new clutch assembly (refer to the applicable steps of Workshop Manual procedure 08.00.BA).
20. Install the torque tube assembly (refer to Workshop Manual procedure 05.01.CB).

21. Please send an email to warranty@astonmartin.com. For the email subject, type:

- The last six characters of the vehicle VIN
- Hyphen (-)
- SA-08-0263/QN-08-0042

For Example: "C00000-SA-08-0263/QN-08-0042".

Name the photograph file as follows:

- The last six characters of the vehicle VIN
- Hyphen (-)
- The batch number of the clutch slave cylinder (this can be 1 or 2)
- Hyphen (-)
- SA-08-0263_QN-08-0042

For example: "C00000-1-SA-08-0263_QN-08-0042.jpg".

Attach a copy of the photograph to the email.

Part Data

Description	Part Number	Quantity
Oil, Transaxle	6G33-75106-AA/S	As necessary
Hydraulic Fluid, ASM	6G33-19H373-BA	As necessary
Clutch Assembly (V8) (only necessary if Client Services give authorisation)	9G33-7540-BD	1
Circlip (drive shaft)	BG33-26-10614	2
Parts for V12 Vantage and GT12 Only:		
Clutch Assembly (V12) (only necessary if Client Services give authorisation)	AD23-7540-AB	1
Socket Head Cap Screw (Clutch attachment)	AD23-CD60-AA	9
Sealing Ring (exhaust)	4G43-17213-BA	2
Gasket (Inlet manifold) (Pack of 2)	1R12-08-10077-PK	1
Seal, Fuel Injector to manifold (green) (Pack of 8)	6G43-08-11260-PK	2
O Ring, Throttle Seal	CD33-9E936-AA	2
Clamp Assembly (Air cleaner hose)	4G43-9N832-BB	2

Warranty Data

If you need to replace the clutch, you must enter the WW number in the "Technician's Write Up" field.

To claim for the part cost:

Click on the "Consequential Damage" box. You can now add the cost of the parts to the claim. Add the labour time in the "Labour Hours Additional" field.

Note: *When you enter the Warranty claim into the Warranty system, please enter the slave cylinder batch number into the Technician's Comments.*

Procedure and Labour Time

There are three tiers in the Warranty database. Please make sure that you refer to the correct tier when you make the Warranty claim.

Description	Model	Task	Labour Time	Tier
Examine the clutch slave cylinder for fluid leaks and if necessary, torque the fluid pipe connectors.	V8 Vantage (All)	Examine	0.1 hours	A
		Repair	6.8 hours	
	V12 Vantage (All)	Examine	0.1 hours	B
		Repair	15.6 hours	
	GT12	Examine	0.1 hours	C
		Repair	16.0 hours	

If you have any questions related to this Quarantine Notice, please contact: Aston Martin Technical Services on: +44 (0) 1926 644720, email: askamtech@astonmartin.com, or contact your After Sales Manager.

The English version of this Quarantine Notice is written in Simplified Technical English to ASD-STE100™.