



Service Bulletin

PRELIMINARY INFORMATION

Subject: Rough Idle In Drive

Models: 2015-2017 Cadillac Escalade Models
2014 Chevrolet Silverado 1500
2015-2017 Chevrolet Silverado 1500, Suburban, Tahoe
2014 GMC Sierra 1500
2015-2017 GMC Sierra 1500, Yukon Models
With engines 4.3L, 5.3L, 6.2L RPO L83, L86, LV1, LV3

This PI was superseded to update Model Years. Please discard PIP5211E.

The following diagnosis might be helpful if the vehicle exhibits the symptom(s) described in this PI.

Condition/Concern

Some customers may comment about a rough idle and/or vibration at idle in Drive.

This condition may be most noticeable following extended driving, after hard acceleration, while idling at a stop in Drive.

May feel like a lopey or lumpy idle, or may be described as a low idle.

This condition will not be present in Park, or Neutral.

(There have been a few cases for rough idle in Reverse.)

Note: There will not be any DTCs with this concern.

Recommendation/Instructions

This concern may be caused by ground out within the one or both engine mounts.

Familiarize yourself with the entire PI before proceeding.

If the rough idle / vibration concern is E1.5 in the horizontal / lateral direction with Pico sensor mounted in seat track as indicated – continue with steps to reduce the amplitude (mg) of the vibration by adding spacers in key locations to reduce / eliminate ground out within the engine mounts

Note: The 6.2L engine has a characteristic E1 which can be felt, and may be described as a lopey idle. V8 engine firing frequency produces E4 which will typically be very low frequency at the seat track. Do not confuse 6.2L E1 characteristic (not caused by mount ground-out), with E1.5 normal idle characteristics being transmitted into the truck via ground-out thru the engine mounts.

Initial Setup, Duplication / Evaluation:

Measure the vibration disturbance using the vibration analyzer, CH-51450-A (Pico Oscilloscope), to qualify whether the issue is E1.5 as opposed to E1 or E4.

Note: If using a single-axis pico sensor, mount and test both vertically and horizontally – E1.5 rough idle vibration will usually be horizontal / lateral at the seat track.

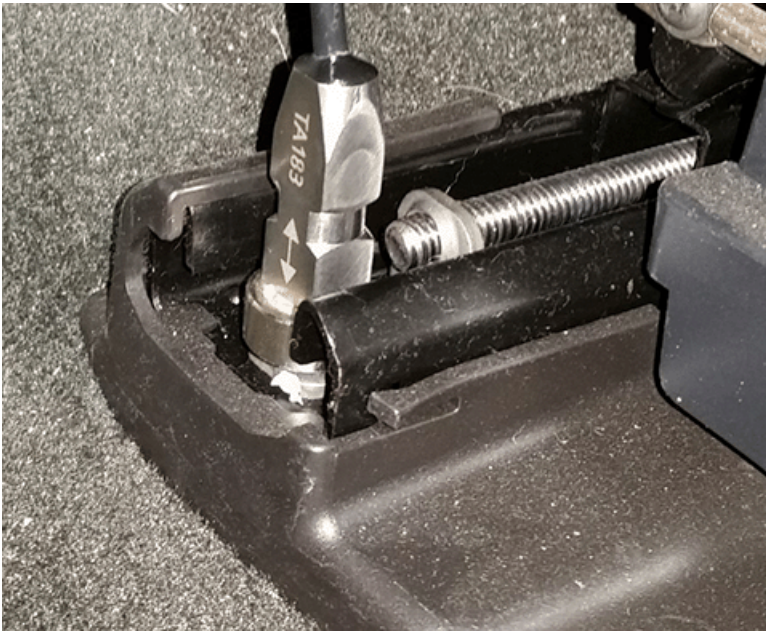

Add E1.5 to the displayed data and turn off T and P related data (under Add Vibration in Pico) since issue occurs with vehicle stationary.

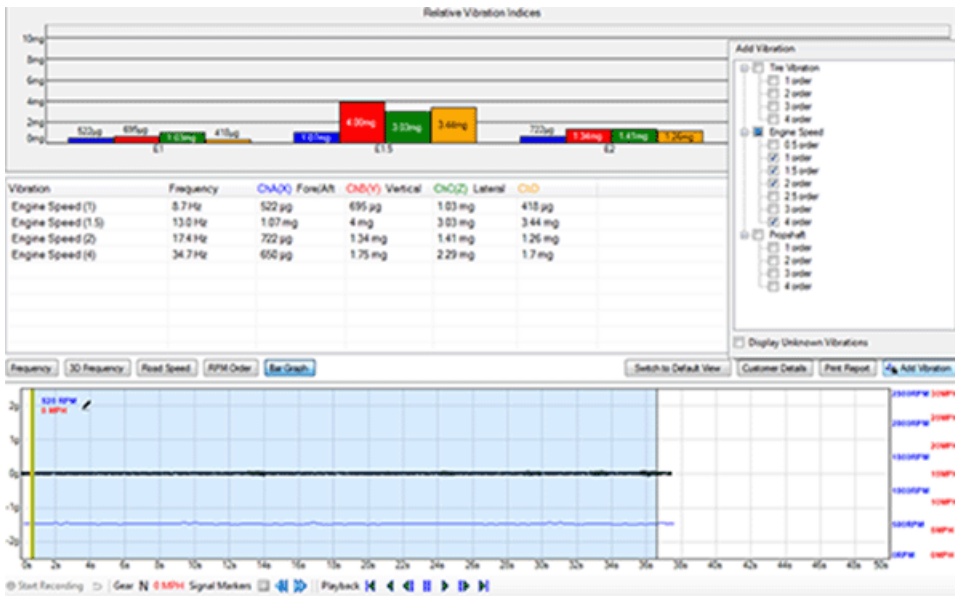

Note: Amplitude (mg) readings from a single-axis pico sensor will be approximately 10% lower than with a tri-axis sensor. For example a reading of 4 mg using a tri-axis sensor, would likely measure as about 3.6 mg on a single-axis sensor.

If the disturbance measures at the seat track as E1.5 lateral in the range of approximately 2.5 - 8 mg or higher using a tri-axis sensor, continue with steps in this PI to reduce the amplitude (mg) of the disturbance, then exercise the vehicle and re-measure using pico to determine level of improvement.

For vehicles measuring high at the seat track – perhaps 12 mg or greater; replacement of the engine mounts should help bring the disturbance back in line; then it can be re-evaluated.

If the E1.5 disturbance measures very close to or less than approximately 2 mg – using the Pico tri-axis sensor as indicated – the vehicle is considered acceptable.

1. Place tri-axis pico sensor on the inboard seat track forward-most location to record measurement of the rough idle vibration concern.

Note: Most rough idle in Drive concerns are temperature dependent, and can be difficult to re-create at times. In addition, time to remove/add spacer washers to the mounts may allow enough cool-down of the mounts that the vibration feels corrected when it is not.

2. With A/C On, perform several short heavy launch events from stop to stop to bring the temperatures back up while attempting to re-create the rough idle vibration in Drive with Pico sensor placed on inboard seat track; while the vibration is active – Record Pico reading. This method seems to provide better results than extended test drives.
3. If the Pico reading for E1.5, with vibration active, at the inboard forward seat track location measures approximately 2.5mg or higher – continue following steps in this PI.
4. If the Pico reading for E1.5, with vibration active, at specified seat track location measures close to 2mg or less – investigate other sources of the rough idle / vibration concern using SI diagnostics.

Stall Setup

1. Have an assistant available throughout procedure to be inside the vehicle during evaluation and while working toward reducing the rough idle condition.
2. Have a wood block and a jack ready to position below the engine lower oil pan to be able to raise the engine slightly when needed during this procedure
3. To ensure most accurate condition, whenever evaluating the rough idle condition to determine baseline and any level of improvement, have the vehicle on the ground at ride height.
4. For improved access to the mounts, remove the front wheelhouse liners.
5. Remove all previously installed spacers from the engine mounts – below the mount to frame perch, and on upper side of mount at frame attachments.

Settling Process:

Important: Do Not use Impact wrenches when tightening the engine mount to frame bolts, or damage to threads in the frame may result.

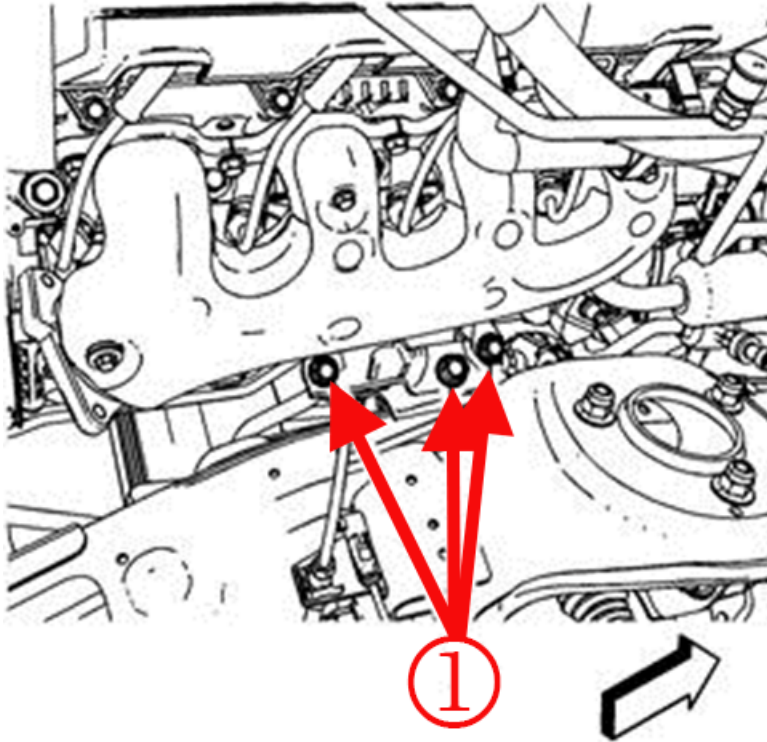

1. Settle all mounts as follows – loosen a couple turns, the engine mount to frame bolts (1) on both LH and RH sides and the transmission/transfer case mount to crossmember nuts.
2. Have assistant set park brake and apply base brake.
3. Have assistant turn Traction Control Off, and brake torque in Drive and Reverse - engine at operating temperature - then place in Neutral and turn engine Off.

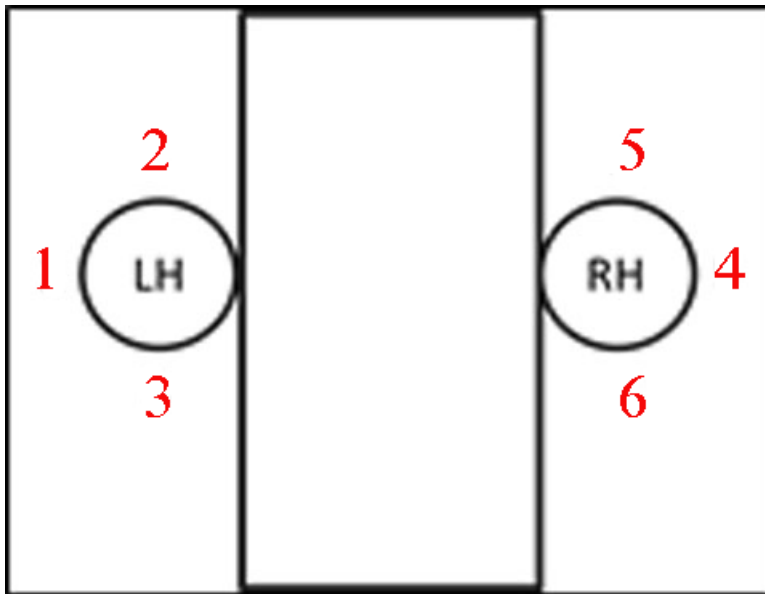

4. In Neutral, with engine Off, using Only Hand Tools, tighten all engine mount to frame bolts in sequence shown, to 50 Nm (37 lb ft); then tighten the transmission/transfer case mount nuts to 55 Nm (40 lb ft).

Follow-up Duplication / Evaluation:

1. Place tri-axis pico sensor on the inboard seat track forward-most location to record measurement of the rough idle vibration concern.
Note: Most rough idle in Drive concerns are temperature dependent, and can be difficult to re-create at times. In addition, time to remove/add spacer washers to the mounts may allow enough cool-down of the mounts that the vibration feels corrected when it is not.
2. With A/C On, perform several short heavy launch events from stop to stop to bring the temperatures back up while attempting to re-create the rough idle vibration in Drive with Pico sensor placed on inboard seat track while; the vibration is active – Record Pico reading. This method seems to provide better results than extended test drives.

3. If the Pico reading for E1.5, with vibration active, at the seat track measures less than 12 mg – continue to Adjustment Process steps, below.
4. If the Pico reading for E1.5, with vibration active, at the forward seat track measures approximately 12 mg or higher at this point, regardless of mileage or age of vehicle, replace both engine mounts, then repeat steps 1-4 under Settling Process to resettle mounts and attempt to recreate rough idle vibration, then continue with next steps.

Adjustment Process:

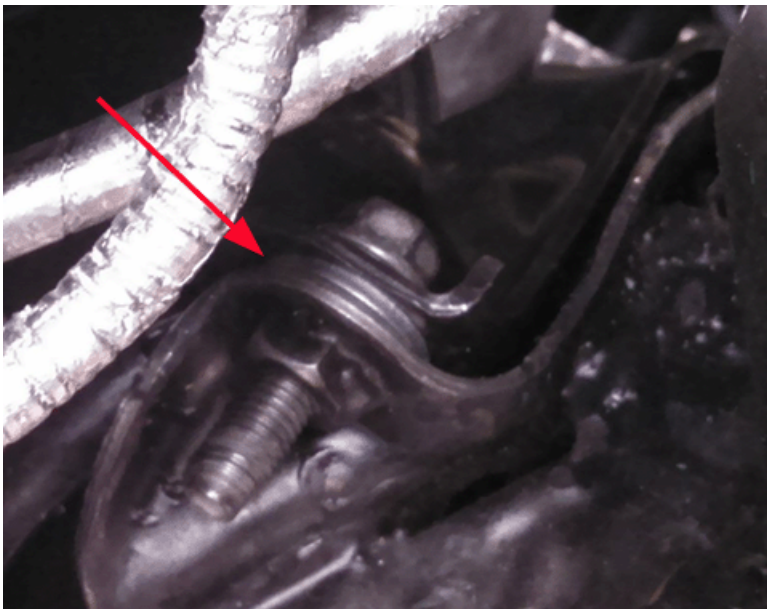
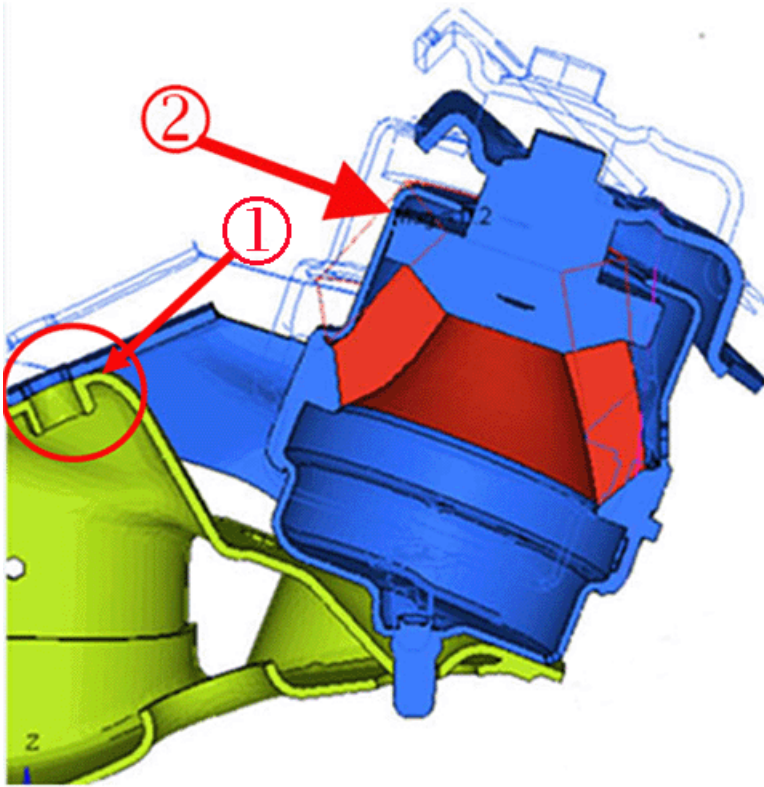

Spacer Washer at Frame Bolt Location Example

Note: Often the idle vibration caused by ground-out within an engine mount (2) may be able to be turned off/on with a single bolt location – shimming that bolt location may greatly reduce the vibration. In some cases, a combination of bolt location shimming may be needed.

Note: For spacer washers mild steel is recommended, no stainless; it may be necessary for some locations to use a small amount of adhesive such as 'dum-dum' to hold spacer in place.

Note: For any engine mount to frame bolts removed during this process – clean bolt threads using denatured alcohol or equivalent; then apply threadlocker or equivalent to the bolt threads. Refer to Adhesives, Fluids, Lubricants, and Sealers.

Important: Do Not use Impact wrenches when tightening the engine mount to frame bolts, or damage to threads in the frame may result.

1. With assistant running vehicle in stall, park brake set and base brake applied, in Drive, monitoring E1.5 on Pico at inboard seat track, with idle vibration active, perform the following:
 - 1.1. Beginning with RH side, begin to loosen engine mount to frame bolts one at a time a few turns to release clamp load – begin with rear bolt (follow reverse order of tightening sequence: rear, front, middle).
 - 1.2. Pause after loosening any of the mount bolts during these steps to determine effect on the idle vibration on Pico at the seat track – make note of effect from each bolt location.
 - 1.3. If idle vibration was significantly reduced, tighten same bolt to see if it comes back.
 - 1.4. If idle vibration could Not be turned off/on with that bolt, tighten bolt then loosen next bolt – front bolt.
 - 1.5. If idle vibration could Not be turned off/on – repeat process with middle bolt.
 - 1.6. If the idle vibration Could be turned off/on with one bolt, add a spacer washer, approximately 2.5 mm thick (1) when the engine mount and frame attachment at that bolt location.
2. If there was no bolt location on the RH mount which could turn the idle vibration off/on – repeat process on LH mount.
3. Tighten the affected engine mount to frame bolts in sequence, to specification.
4. If there was not a single bolt location on the RH or LH mount which could turn the idle vibration off/on – shimming will be necessary for 2 or 3 bolt locations on one side. Go back to the 2 bolts with greatest effect recorded on vibration on one side and shim those bolts.
5. Re-evaluate the rough idle vibration – repeating steps 1-4 under Follow-up Duplication / Evaluation
If the E1.5 idle vibration at inboard seat track forward location has been reduced to less than 3 mg – determine with customer if condition is now acceptable.

Fine Tuning - Pico Sensor on Mounts (if Needed):



Note: It is difficult to lower amplitude of E1.5 idle vibration at the seat track to about 2.5 mg or lower. Many customers are satisfied with approximately 3 mg or less. Some customers may not be satisfied until the idle vibration is brought below 3 mg, closer to 2.5 mg.

The following steps may help further reduce initial results from steps 1-5 under Adjustment Process.

The Pico sensor is used to determine bolt location by bolt location which bolt or bolts to shim. Results could range from 1 bolt to 2 bolts, or perhaps all 3 bolt locations.

Important: Do Not use Impact wrenches when tightening the engine mount to frame bolts, or damage to threads in the frame may result.

6. While the tri-axis sensor is mounted on the inboard seat track forward most location, Channels A-C – Add a second Pico sensor tri-axis or single plane using Channel D.
7. Place the added Pico sensor on the middle engine mount bolt head, beginning with RH side.
8. For Pico readings from the mount, focus on Vertical E1.5. (suggest removing lateral and fore/aft channels from display, and removing E1 and E4 from display).
9. While the idle vibration is active, record the E1.5 amplitude (mg).
10. Repeat steps 6-9 for LH side while the idle vibration is active, and compare readings.
11. Focusing on the side with highest E1.5 amplitude (mg), perform the following:
 - 11.1. Place the added Pico sensor on the engine mount rear bolt head.

- 11.2. While the idle vibration is active, record the E1.5 amplitude (mg).
- 11.3. Move sensor to middle bolt head and repeat.
- 11.4. Move sensor to front bolt head and repeat.
- 11.5. if a spacer washer is not already in position, Add a spacer washer, approximately 2.5 mm thick between the engine mount and frame attachment at the bolt location with the highest recorded E1.5 amplitude (mg).
12. Re-evaluate the rough idle vibration – repeating steps 1-4 under Follow-up Duplication / Evaluation
13. If the E1.5 idle vibration at inboard seat track forward location has been reduced below 3 mg – determine with customer if condition is now acceptable.
14. If the E1.5 idle vibration at inboard seat track forward location has not been reduced below 3 mg, if a spacer washer is not already in position, add a spacer washer, approximately 2.5 mm thick between the engine mount and frame attachment at the bolt location with the second-highest recorded E1.5 amplitude (mg). (Leave the spacer washer at the highest recorded bolt location.)
15. Re-evaluate the rough idle vibration – repeating steps 1-4 under Follow-up Duplication / Evaluation.

Warranty Information

For vehicles repaired under warranty use:

Labor Operation	Description	Labor Time
4081038*	Shim Both Engine Mounts	2.2 hr
* This is a unique labor operation for bulletin use only.		

Please follow this diagnostic or repair process thoroughly and complete each step. If the condition exhibited is resolved without completing every step, the remaining steps do not need to be performed.

GM bulletins are intended for use by professional technicians, NOT a "do-it-yourselfer". They are written to inform these technicians of conditions that may occur on some vehicles, or to provide information that could assist in the proper service of a vehicle. Properly trained technicians have the equipment, tools, safety instructions, and know-how to do a job properly and safely. If a condition is described, DO NOT assume that the bulletin applies to your vehicle, or that your vehicle will have that condition. See your GM dealer for information on whether your vehicle may benefit from the information.



WE SUPPORT VOLUNTARY TECHNICIAN CERTIFICATION