



INSTRUCTION TO SERVICE

ITS:6364

SECTION:

219 Engine and Transmission

WRITTEN BY:

Mike Pearson

SUBJECT:

Rework Heat Exchanger Cabin Loop Line and Routing

ITS6364

THIS DOCUMENT AND THE CONTENTS DISCUSSED HEREIN ARE THE CONFIDENTIAL AND PROPRIETARY INFORMATION OF NEW FLYER INDUSTRIES CANADA ULC AND NEW FLYER OF AMERICA INC. AND ARE DISCLOSED BY NEW FLYER IN CONFIDENCE. THIS DOCUMENT AND THE CONTENTS HEREIN ARE NOT TO BE DISCLOSED BY THE INTENDED RECIPIENT WITHOUT THE PRIOR WRITTEN AUTHORIZATION OF NEW FLYER. ANY UNAUTHORIZED DISCLOSURE, REPRODUCTION OR OTHER DISTRIBUTION OF THIS DOCUMENT OR INFORMATION IS STRICTLY PROHIBITED AND MAY RESULT IN ACTION BEING TAKEN AGAINST THE PARTY MAKING THE UNAUTHORIZED DISCLOSURE. THIS DOCUMENT AND ALL COPIES HEREOF MUST BE RETURNED TO NEW FLYER UPON REQUEST.



NEW FLYER

PROCEDURE:

1. Turn the main battery disconnect switch to the “OFF” position.
2. Open the surge tank fill door.
3. Relieve the cooling system pressure by lifting the vent lever on the cabin heat surge tank pressure relief cap. See Figure 1.

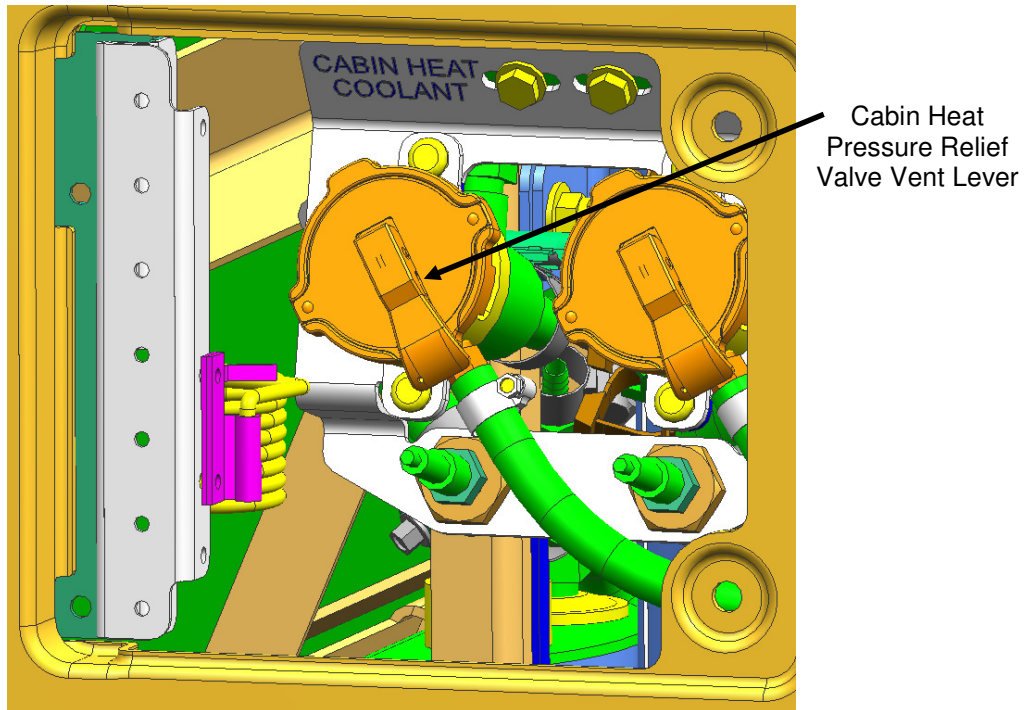

Figure 1: Cabin Heat Surge Tank Pressure Relief

NOTE: If coolant is to be recovered, make sure container is clean and chemical free. If not, used coolant must be recycled or disposed of in accordance with municipal, state and federal government regulations.

4. Place a suitable container under the heat exchanger cabin loop drain plug. Remove and save the drain plug and drain cabin heat coolant circuit. See Figure 2.
5. If necessary, raise the coach in accordance with the New Flyer Service Manual.
6. Remove and discard the existing tube clamp and mounting hardware supporting the heat exchanger cabin loop SST tube to the degas frame as shown in Figure 2.
7. Remove and discard the existing tube clamp and mounting hardware supporting the heat exchanger cabin loop SST tube to the clamp mounting bracket (bracket may vary in appearance) as shown in Figure 2 and 3.
8. The cabin heat coolant tube support clamp mounting bracket may vary in appearance, remove the bolts from the forward lower radiator tube mounting bracket, remove and discard existing cabin heat coolant tube bracket and re-install the lower radiator tube mounting bracket bolts. Torque bolt (x2) to 40-70 in*lbs dry, see Figures 2 & 3.
9. Remove and save the existing hose clamp from the silicone elbow on the booster pump line to the SST cabin loop tube, see Figure 2.
10. Remove and save the existing hose clamps (x4) from the silicone hose connecting the heat exchanger 90° SST elbow to the SST tube to the booster pump, see Figure 2.



NEW FLYER

- 11. Remove and discard the existing silicone hose and SST cabin loop tube, see Figure 2.
- 12. Open coolant ports and/or hoses are to be covered with a clean dry lint free cloth.

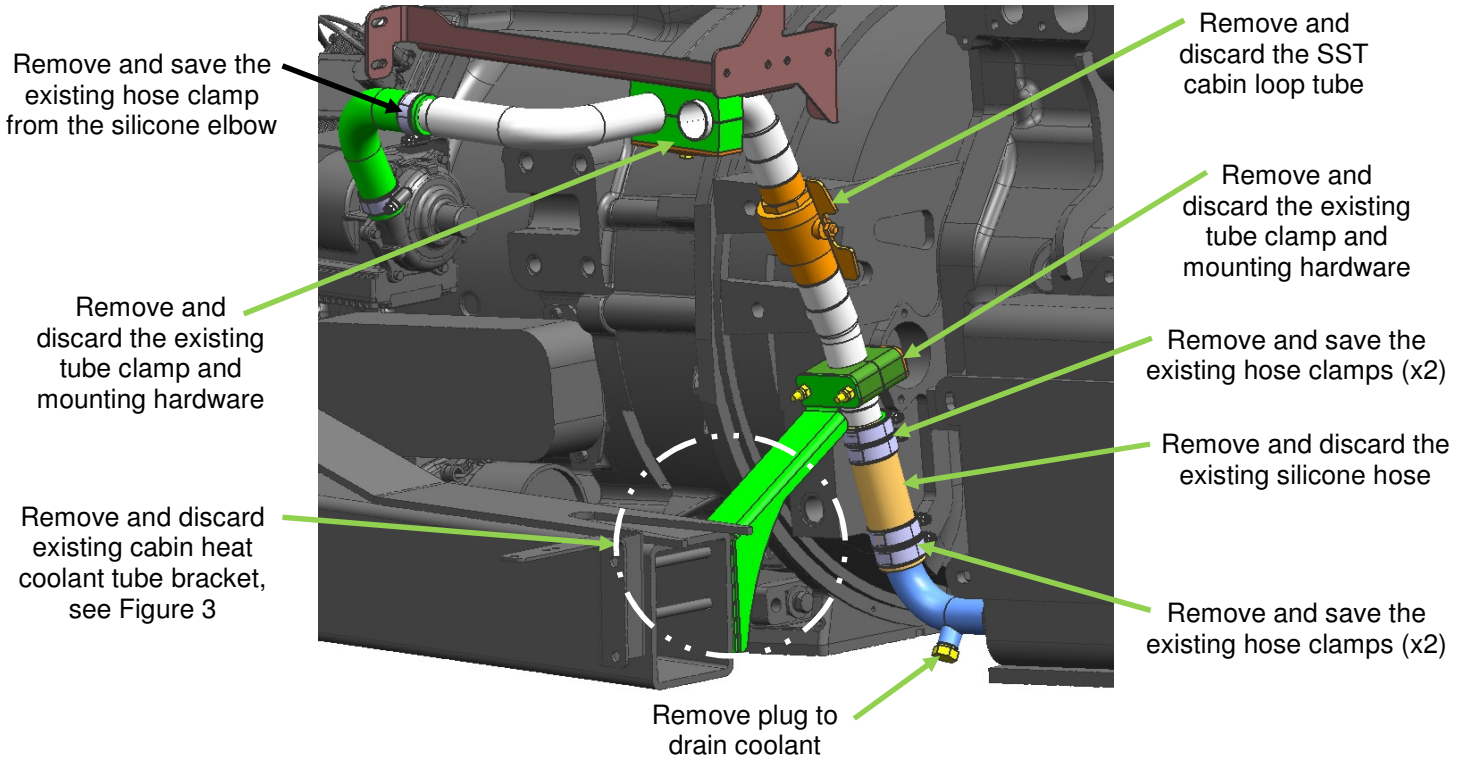
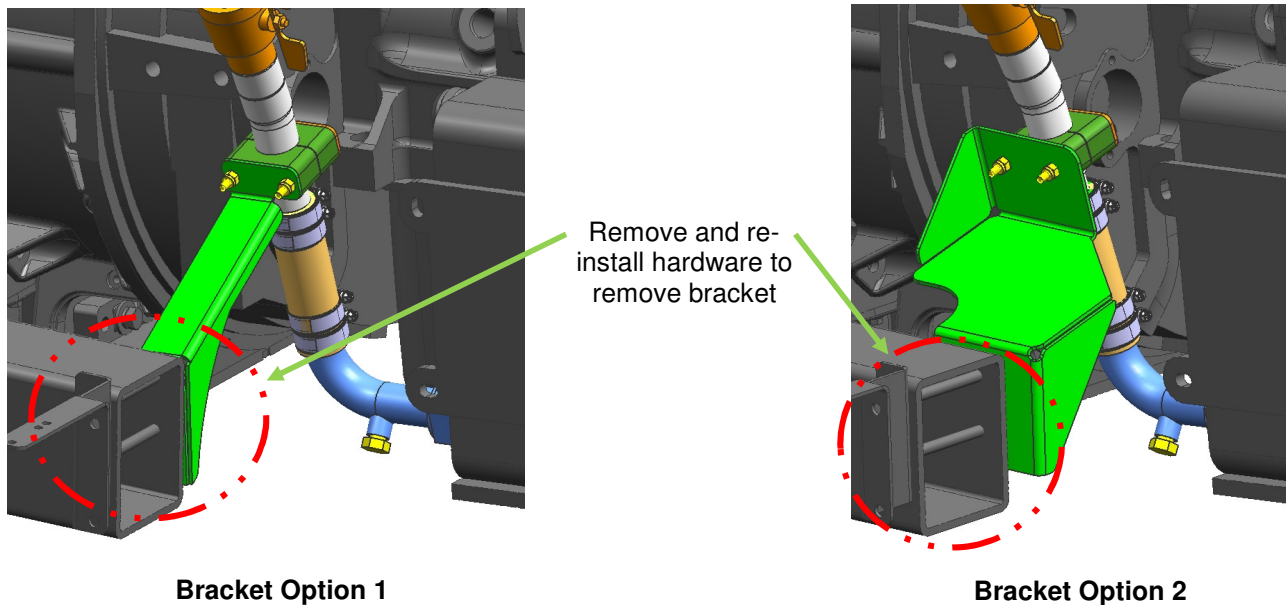

Figure 2: Cabin Heat Coolant Tube Removal



Bracket Option 1

Bracket Option 2

Figure 3: Coolant Tube Clamp Support Bracket Options



NEW FLYER

13. Mark and drill a 0.28 Dia clearance hole through the existing de-gas frame as shown in Figure 4.

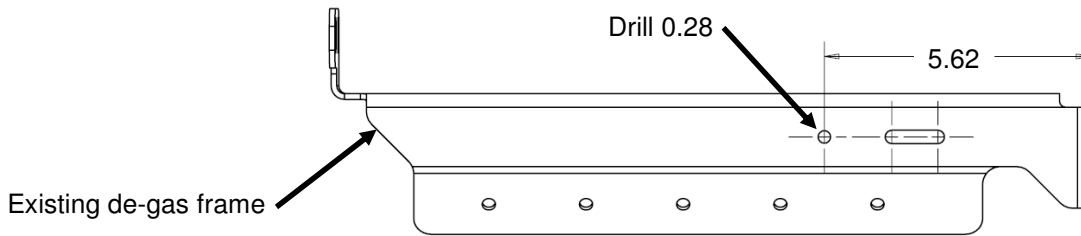

Figure 4: De-gas Frame Bracket Rework (as shown from the bottom)

14. Using the newly drilled hole from Step 13 and an existing slot in the de-gas frame install the new tube support bracket p/n 647853 using new bolts p/n 10B04012 (x2), washers p/n 10W04000 (x4) and lock nuts p/n 40N04000 (x2), torque hardware to 12 ft*lbs dry. See Figure 5.
15. Loosely install the new tube assy p/n 647859 to the newly installed bracket from Step 14 using p-clips p/n 247230 (x2), washer p/n 10W04000 (x4) and lock nuts p/n 40N04000 (x2). See Figure 5.
16. When installing the new tube assy to the newly installed bracket, the end to the booster pump is to be loosely installed into the existing silicone elbow at the pump using existing clamp from Step 9. If existing silicone elbow is worn or does not fit correctly to the new tube assy it should be replaced with a new elbow p/n 580701. New elbow it to be trimmed to fit.

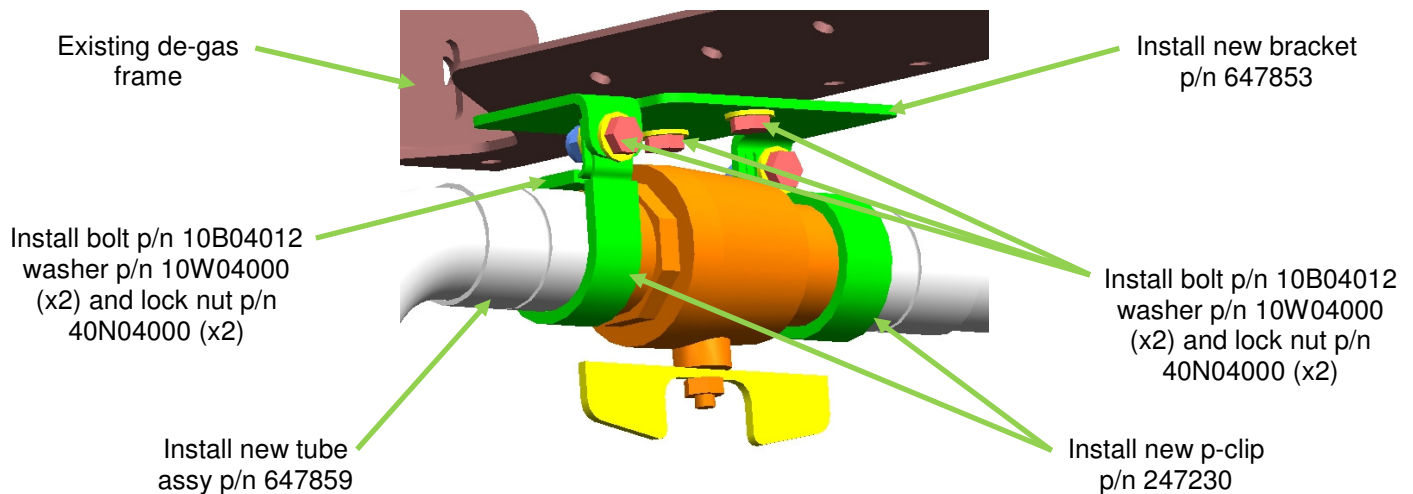

Figure 5: Tube and Support Bracket Assembly Installation

17. Loosely install approx. 14" of new Venair hose p/n 555447 (trim hose to fit) between existing heat exchanger cabin heat SST elbow and newly installed tube from Step 16 using existing hose clamps removed in Step 10, two (2) at each end of the hose.
18. Ensure the hose and tube is free of kinks and routed in a relaxed state and tighten clamps as follows.
 - a. Tighten existing tube assy p-clip hardware installed in Step 13 to 12 ft*lbs dry.
 - b. Tighten the existing silicone elbow clamp from Step 13 to 80 in*lbs. Dry. Tighten at 75 rpm or less, re-torque to 80 in*lbs. at 75 rpm or less after 30 mins.



NEW FLYER

- c. Tighten the existing silicone hose clamps from Step 15 to 80 in*lbs. Dry. Tighten at 75 rpm or less, re-torque to 80 in*lbs. at 75 rpm or less after 30 mins.
19. Install the coolant drain plug removed in Step 4 as per Step 20.
 20. Fitting installation:
 - a. Inspect the threads to be sure they are not damaged or contain slivers, burrs, dirt or other contaminants.
 - b. Apply thread sealant p/n 8110442 evenly, without air pockets, around the circumference of the thread, leaving the first 1/2 to 1 1/2 threads unpasted and extend to completely cover a minimum of the next three threads. Ensure that orifices remain unblocked. **Note: Threads supplied with Vibra-Seal coating (red dry seal) do not require additional thread sealant.**
 - c. Install the fitting finger tight.
 - d. Apply two full turns past finger-tight.

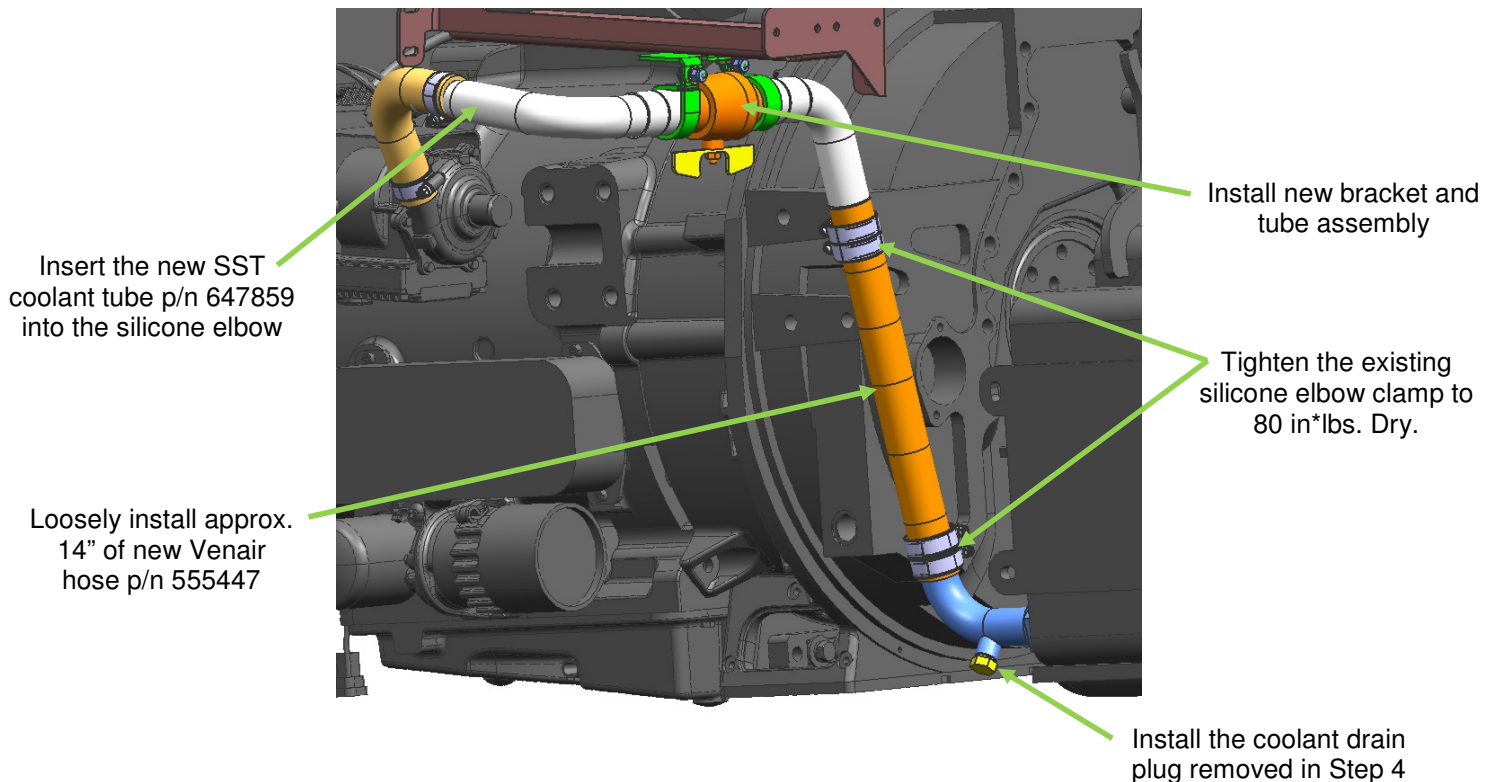

Figure 6: Cabin Heat Coolant Tube Installation

21. If necessary, lower coach in accordance with the New Flyer Service Manual.
 22. Remove all tools and debris and return the bus to service condition.
 23. Close the surge tank access door.
 24. Turn the main battery disconnect switch to the "ON" position.
- NOTE:** It will be necessary to perform a cooling system deaeration procedure prior to starting the engine if any other maintenance activity is performed on the heating system that could have introduced a significant amount of air into the cooling system. Refer to New Flyer Drawing p/n 608544 "Cabin System Coolant Fill Procedure" or Section 2.4.4. Filling and Deaeration in the New Flyer Service Manual.



NEW FLYER

LABOUR ESTIMATE

	Operation	Men	Hours	Labour Time M X HR
1	Rework Heat Exchanger Cabin Loop Line and Routing	1	2.0	2.0

PARTS REQUIRED

Item	Part Number	Description	Qty. per Coach	Units	Notes
1	6468308	Kit-Assy for ITS-6364	1	EA	Kit consists of the following parts
1	647859	Assembly-Booster Pump Supply	1	EA	
2	555447	Hose-Venair 31 mm ID	0.33	EA	
3	081034	Loctite 243-Medium 10 ml	0.01	EA	
4	647853	Bracket-Booster Pump Line Support	1	EA	
5	10B04012	Bolt-Hex ¼ UNC x 0.75"	6	EA	
6	10W04000	Washer-Flat ¼" NOM	8	EA	
7	40N04000	Nut-Hex Lock ¼"	4	EA	
8	247230	Clamp-P 1.500	2	EA	