



Technical Service Bulletin

SUBJECT:			No: TSB-16-00-008
2015 LANCER EVOLUTION “FINAL EDITION” SERVICE MANUAL INFORMATION – SERVICE MANUAL REVISION			DATE: June, 2016
			MODEL: 2015 Lancer Evolution Final Edition
CIRCULATE TO:	<input type="checkbox"/> GENERAL MANAGER	<input checked="" type="checkbox"/> PARTS MANAGER	<input checked="" type="checkbox"/> TECHNICIAN
<input checked="" type="checkbox"/> SERVICE ADVISOR	<input checked="" type="checkbox"/> SERVICE MANAGER	<input checked="" type="checkbox"/> WARRANTY PROCESSOR	<input type="checkbox"/> SALES MANAGER

PURPOSE

A 2015 Lancer Evolution “Final Edition” Service Manual will not be issued. Use the 2014 Lancer Evolution Service Manual along with this TSB and TSB-14-00-019 for complete maintenance and repair information for the 2015 Lancer Evolution “Final Edition.”

AFFECTED VEHICLES

2015 Lancer Evolution “Final Edition”

AFFECTED SERVICE MANUALS

2014 Lancer Evolution Service Manual:

- Group 00 – General
 - Vehicle Identification
- Group 11B – Engine Overhaul
 - General Description
 - Cylinder Head and Valves
- Group 13A – Multiport Fuel Injection (MFI)
 - General Description
- Group 42D – Body Repair
 - Body Color
- Group 51 – Exterior
 - General Information
 - Mark
- Group 52A – Interior
 - General Information
 - Floor Console Assembly



GROUP 00

GENERAL

CONTENTS

VEHICLE IDENTIFICATION **00-2** **MODELS** **00-2**

00-2

GENERAL
 VEHICLE IDENTIFICATION

VEHICLE IDENTIFICATION

MODELS

M1001000308970

VEHICLE IDENTIFICATION NUMBER LIST

VEHICLES FOR USA

(VEHICLES FOR 50 STATES)

VIN (Except serial number)	Model code		Engine model	Transaxle model	Fuel system
JA32W8FV_FU	CZ4AS	NXFZL2M	4B11 [1,998 cm ³ (121.9 cu in) DOHC MIVEC gasoline engine with charge air cooler turbocharger]	W5M6A (AWD, 5M/T)	MFI

VEHICLES FOR CANADA

VIN (Except serial number)	Model code		Engine model	Transaxle model	Fuel system
JA32W8FV_FU	CZ4AS	NXFZL3M	4B11 [1,998 cm ³ (121.9 cu in) DOHC MIVEC gasoline engine with charge air cooler turbocharger]	W5M6A (AWD, 5M/T)	MFI

GROUP 11B

ENGINE OVERHAUL

CONTENTS

GENERAL DESCRIPTION.....	11B-2	CYLINDER HEAD AND VALVES....	11B-2
		REMOVAL AND INSTALLATION	11B-2

11B-2

ENGINE OVERHAUL
GENERAL DESCRIPTION

GENERAL DESCRIPTION

M1113000102336

OUTLINE OF CHANGES

How to handle the exhaust valve has been added as a sodium-filled valve has been introduced.

CYLINDER HEAD AND VALVES

REMOVAL AND INSTALLATION

M1113006903861

VALVE HANDLING PRECAUTIONS

⚠ WARNING

Sodium reacts violently with water or moisture, generating heat and liberating hydrogen. It must be handled with utmost care because otherwise the following dangerous conditions may result:

- ***Loss of eyesight if sodium gets in eyes.***
- ***Burns if sodium contact skin.***
- ***Fire hazard.***

1. Handling of Sodium-filled Exhaust Valves
 - (1) Sodium-filled exhaust valves are not dangerous and may be handled in the same way as ordinary valves unless they are broken.
 - (2) Never try to break the valves and expose sodium to the air.
 - (3) When worn exhaust valves are to be discarded, have them disposed of by a salvage company equipped with special disposal system, notifying them that the valves contain sodium.
 - (4) Should the exhaust valves be broken, neutralize sodium using the method described below, and discard the valves in the same way as ordinary valves.
2. How to Neutralize Sodium
 - (1) Place a container filled with more than 10 liters (10.6 qt) of water in a well ventilated large space.
 - (2) Wear rubber gloves and goggles, and carefully take out broken valves from the cylinder head.

ENGINE OVERHAUL
 CYLINDER HEAD AND VALVES

11B-3

CAUTION

- Valves must be neutralized one at a time.
- Put a valve in the container only after sodium in the preceding one has completely reacted with water.
- Do not let the solution contact the eyes or the skin.
- Should it get in the eyes, immediately flush them with clean water thoroughly, and receive medical attention. When it contacts the skin, wash with ample amounts of clean water.

- (3) Put a broken valves in the water-filled container and quickly get away from the container at least 2 or 3 m (6.6 or 9.8 ft)
- (4) Keep fire away from the container during the neutralization. The resulting hydrogen gas is highly explosive.
- (5) After the reaction has completed (hydrogen gas is not generated any longer), take out the valve with large tweezers.

NOTE: The reaction occurs when water enters the cavity in the valve. Hydrogen gas may be trapped inside the valve, temporarily blocking the water passage. In such a case, wait until hydrogen gas is released and remaining sodium reacts with water.

- (6) After the neutralization of sodium, water in the container contains sodium hydroxide and is highly alkaline. The water solution should be disposed of according to local regulations.

INSPECTION

M1113007003236

VALVE GUIDE <EXHAUST VALVE SIDE>

Measure the inside diameter at the upper side of the valve guide, and the outside diameter of the valve stem. Then calculate the clearance between the two. If it exceeds the limit, replace the valve guide or/and the exhaust valve. Follow the table below to select an appropriate exhaust valve, which matches the measured inside diameter of the guide.

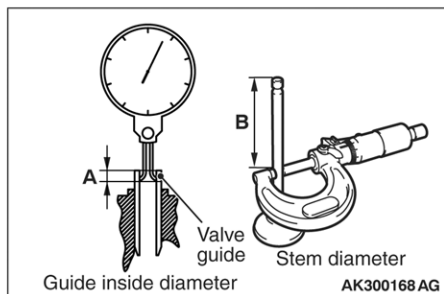

Inside diameter of the guide	5.500 – 5.503 mm (0.21654 - 0.21665 inch)	5.504 – 5.512 mm (0.21669 - 0.21701 inch)
Outside diameter of the stem	5.451 – 5.455 mm (0.21461 - 0.21476 inch)	5.455 – 5.459 mm (0.21476 - 0.21492 inch)

Measurement points:

- A: Approximately 5 mm (Approximately 0.2 inch)**
- B: Approximately 60 mm (Approximately 2.4 inch)**

Standard value:

0.045 – 0.057 mm (0.0018 – 0.0022 inch)

Limit:

0.067 mm (0.0026 inch)

13A-1

GROUP 13A

MULTIPOINT FUEL INJECTION (MFI)

CONTENTS

GENERAL DESCRIPTION. [13A-2](#)

13A-2

MULTIPOINT FUEL INJECTION (MFI) GENERAL DESCRIPTION

GENERAL DESCRIPTION

M1131000107810

OUTLINE OF CHANGES

The following change is made. The other service procedure are the same as the conventional ones.

- Only the identification No. at Engine control module was changed.

GENERAL SPECIFICATIONS

Items		Specifications
Engine control module	Identification No.	E6T82281

42D-1

GROUP 42D

BODY REPAIR

CONTENTS

BODY COLOR	42D-2	BODY COLORING	42D-3
GENERAL INFORMATION	42D-2	RADIATOR GRILLE	42D-3
BODY COLOR CHARTS	42D-2	TWO-TONE	42D-4

42D-2

BODY REPAIR BODY COLOR

BODY COLOR

GENERAL INFORMATION

OUTLINE OF CHANGE

M142010000645

- The section "BODY COLOR CHARTS" has been changed.

- The section "RADIATOR GRILLE" has been changed.
- The section "TWO-TONE" has been established.

BODY COLOR CHARTS

M1420160100477

Check the vehicle's body color code, and then use this body color chart to determine the refinishing paint supplier from which the color can be purchased.

Color	Color code		Color number	Color name	Coating film structure	Composition of film
BLACK / BLUE	X42D06	X42	AC11342	Black Mica / Lightning Blue Mica	2P	Interferenced Pearl
		D06	CMD10006		2P	Interferenced Pearl
BLACK / RED	X42P26	X42	AC11342	Black Mica / Red Metallic	2P	Interferenced Pearl
		P26	CMP10026		2M	Metallic
BLACK / DARK GRAY	X42U02	X42	AC11342	Black Mica / Phantom Black Pearl	2P	Interferenced Pearl
		U02	CMU10002		2P	Interferenced Pearl
BLACK / GRAY	X42U17	X42	AC11342	Black Mica / Titanium Gray Metallic	2P	Interferenced Pearl
		U17	CMU10017		2M	Metallic
BLACK / WHITE	X42W13	X42	AC11342	Black Mica / White Pearl	2P	Interferenced Pearl
		W13	CMW10013		3P	Pearl

NOTE:

- The coating film structure indicates top coating only (2M: 2 coat metallic, 2P: 2 coat pearl, 3P: 3 coat pearl).
- For painting, inner panel colors should be similar to the outer panel colors.
- A roof color is placed before the slash, and a body color after the slash, respectively.
- The hood air outlet garnish is coated in black (AC10705).

BODY REPAIR
BODY COLOR

42D-3

BODY COLORING
RADIATOR GRILLE

M1420161200013

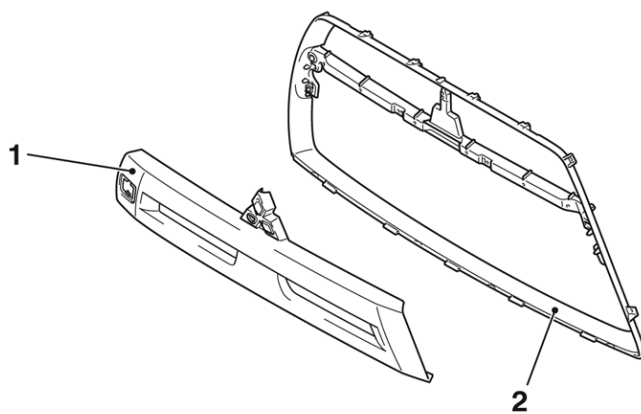

1	Black (AC10705)
2	Chrome plating

ABF00335AB

42D-4

BODY REPAIR BODY COLOR

TWO-TONE

M1420161100027

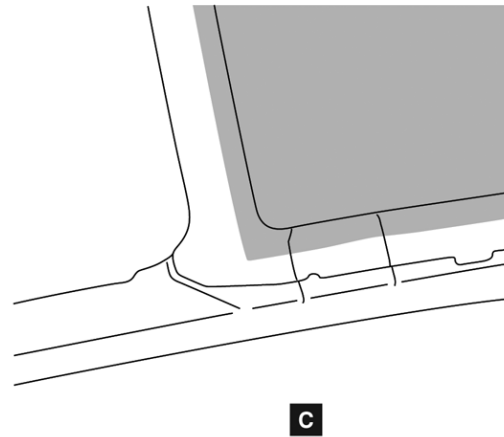
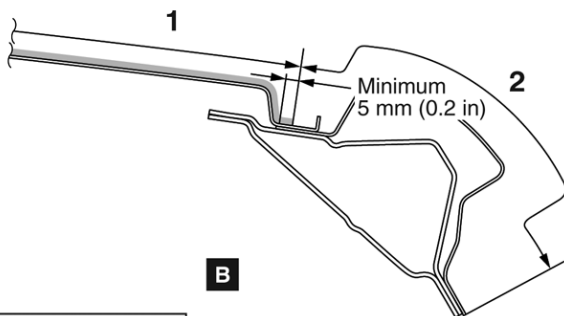
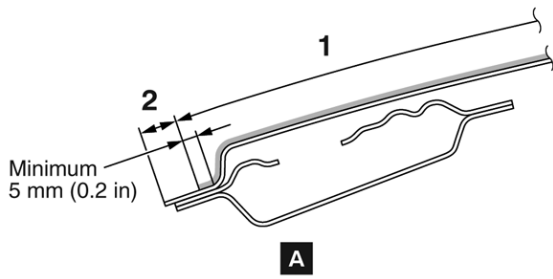
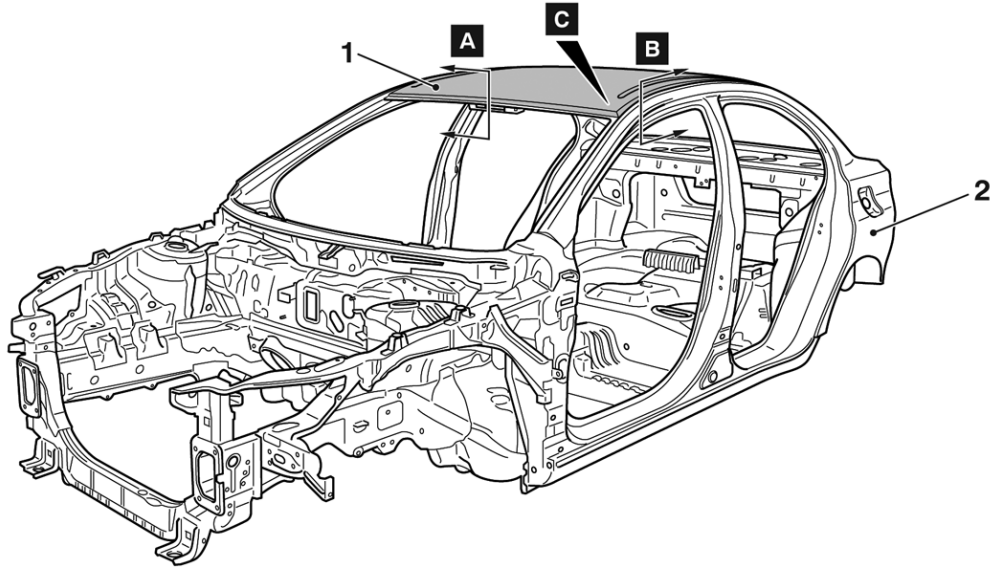

1	Black Mica (AC11342)
2	Body Color

ABF00330AB

**BODY REPAIR
 BODY COLOR**

42D-5

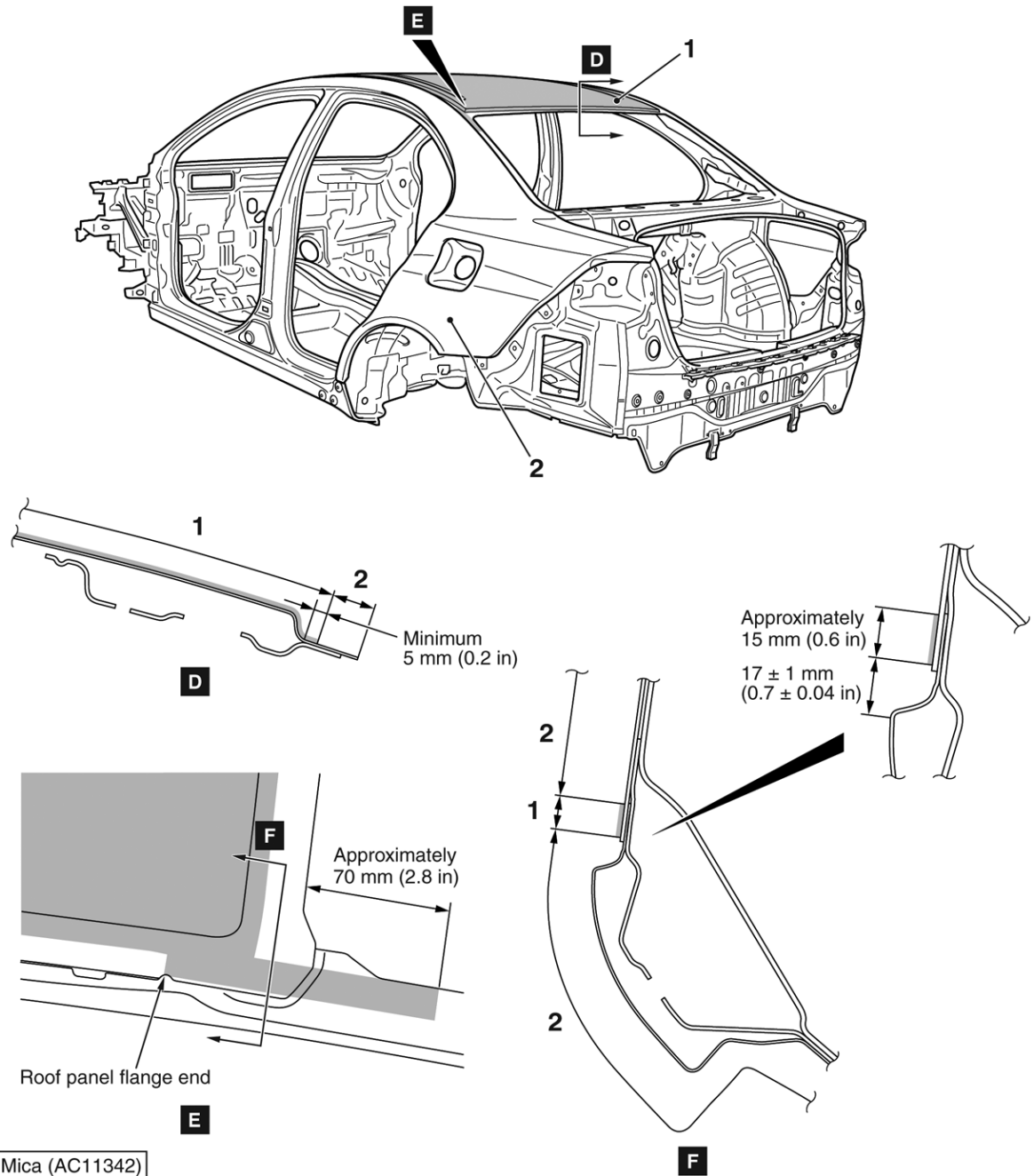

1	Black Mica (AC11342)
2	Body Color

GROUP 51

EXTERIOR

CONTENTS

GENERAL INFORMATION	51-2	MARK	51-2
		REMOVAL AND INSTALLATION	51-2

51-2

EXTERIOR
GENERAL INFORMATION

GENERAL INFORMATION

M1511029400570

OUTLINE OF CHANGES

Due to the addition of LANCER EVOLUTION FINAL EDITION mark, the service procedure has been established. The other service procedures are the same as before.

MARK

REMOVAL AND INSTALLATION

M1511011804360

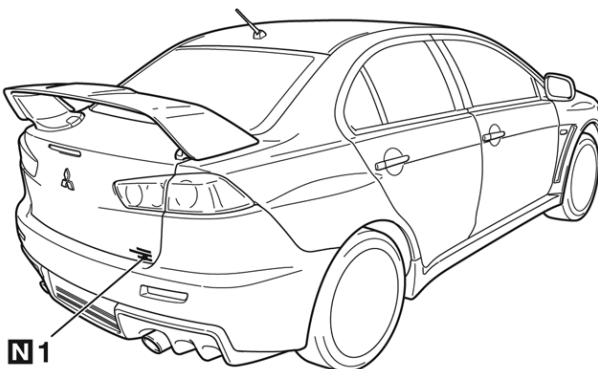

ACA01719AC

Removal

1. LANCER EVOLUTION FINAL EDITION mark

INSTALLATION SERVICE POINT

MARK INSTALLATION

⚠ CAUTION

When attaching the marks, the ambient temperature should be 20 – 38°C (68 – 100°F) and the air should be completely free of dust. If the ambient temperature is lower than 20°C (68°F), the marks and the places on the vehicle body where the marks are to be attached should be heated to 20 – 30°C (68 – 86°F).

1. Installation procedure
 - (1) Use the parts cleaner (MZ100387 or equivalent) to clean the mark installation surfaces on the body.
 - (2) Peel off the protection sheet on the back of the marks to affix it in position.
2. Installation position

Attach each mark to the position shown in the illustration.

EXTERIOR
MARK

51-3

LANCER EVOLUTION FINAL EDITION mark

Unit: mm (in)

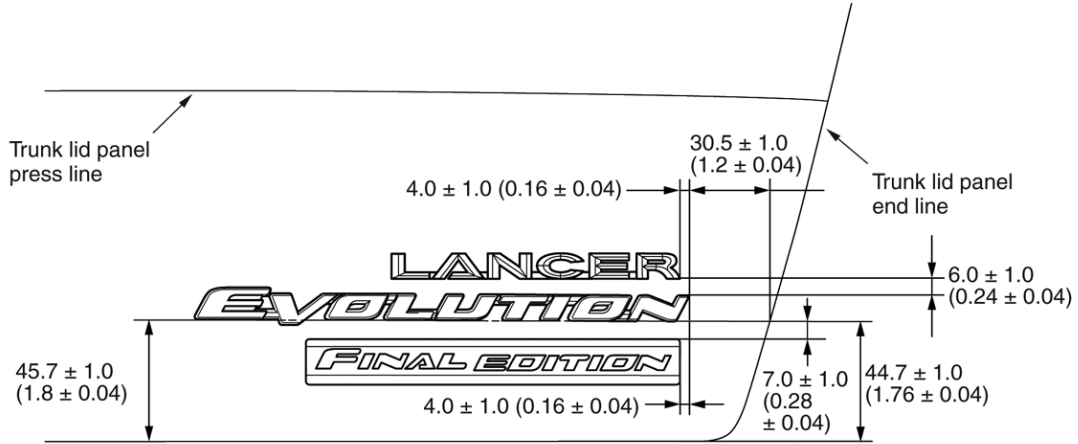

ACF02801AB

52A-1

GROUP 52A

INTERIOR

CONTENTS

GENERAL INFORMATION	52A-2	FLOOR CONSOLE ASSEMBLY	52A-2
		REMOVAL AND INSTALLATION	52A-2

INTERIOR
GENERAL INFORMATION

52A-2

GENERAL INFORMATION

M1521000102027

OUTLINE OF CHANGES

Due to the addition of LANCER EVOLUTION FINAL EDITION plate, the service procedure has been established. The other service procedures are the same as before.

FLOOR CONSOLE ASSEMBLY

REMOVAL AND INSTALLATION

M1521002201674

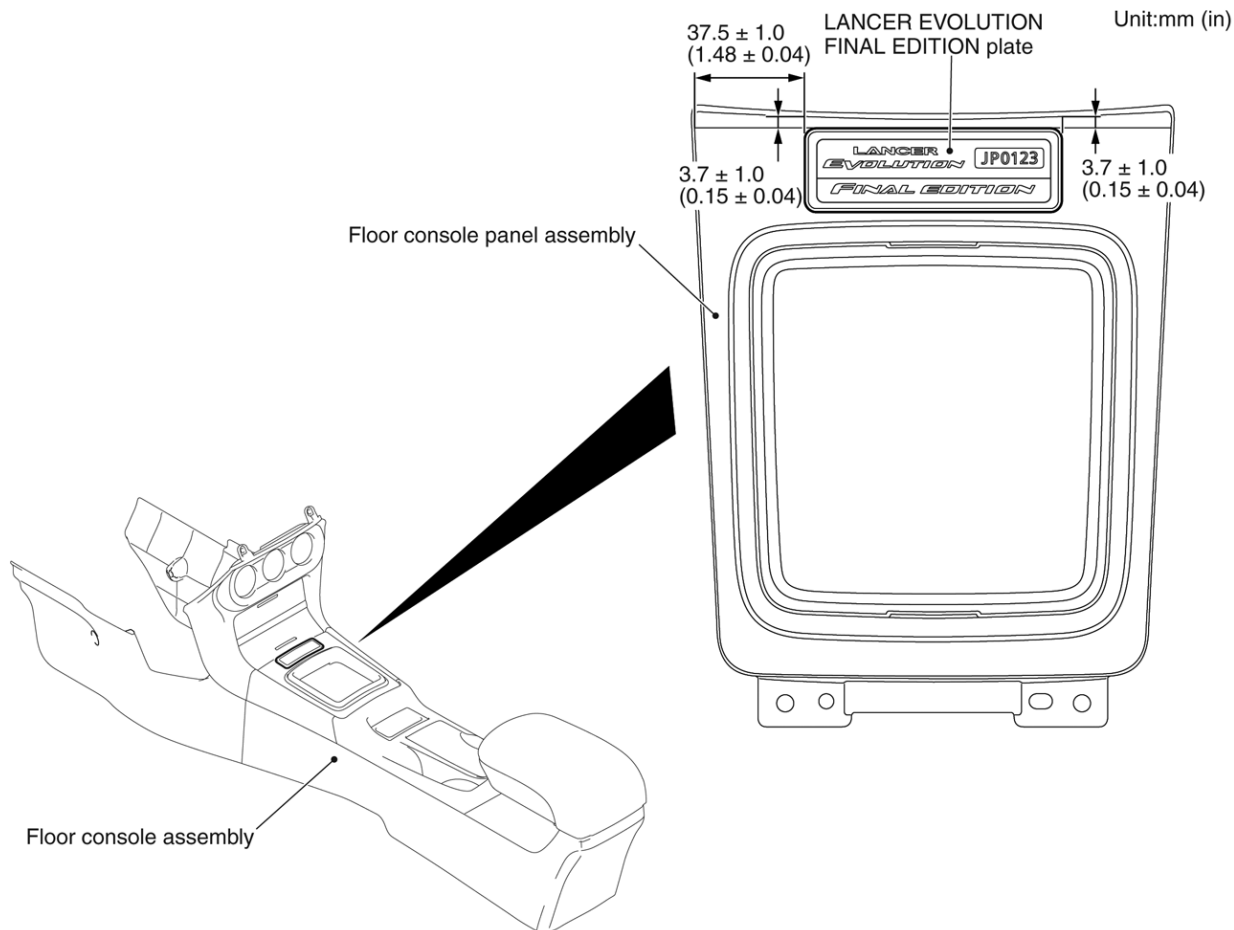

ACF02804AC