



## SERVICE MANUAL BULLETIN

This Service Manual Bulletin is prepared by the Publications Department of New Flyer Industries Canada ULC. Refer to details below.

### SMB-165

ISSUE DATE: Dec 09 2016

APPLICABILITY					
VEHICLE LENGTH	<input type="checkbox"/> 30ft.	<input type="checkbox"/> 35ft.	<input type="checkbox"/> 40ft.	<input type="checkbox"/> 60ft.	<input checked="" type="checkbox"/> ALL
VEHICLE TYPE	<input checked="" type="checkbox"/> Xcelsior®	<input type="checkbox"/> MiDi®	<input type="checkbox"/> Invero®		<input type="checkbox"/> ALL
	<input type="checkbox"/> Low Floor	<input type="checkbox"/> High Floor			
FUEL TYPE	<input type="checkbox"/> Diesel	<input type="checkbox"/> Diesel/Electric	<input type="checkbox"/> CNG	<input type="checkbox"/> LNG	<input checked="" type="checkbox"/> ALL
	<input type="checkbox"/> Fuel Cell	<input type="checkbox"/> Trolley/Electric	<input type="checkbox"/> Battery/Electric		
SUBJECT	Adjuster Check				
SECTION TITLE	1 - FRONT AXLE & SUSPENSION 2 - REAR AXLE & SUSPENSION				
DETAILS	This bulletin provides a minor clarification to the adjuster check procedure for the Knorr-Bremse SN7000 caliper used on the MAN front & rear axles.				

## 1. Adjuster Check

1. Before starting work, ensure that the wheels are chocked and the vehicle cannot roll away.
2. Ensure that service brake and parking brake are in the released condition.
3. Check the supply pressure of the brake system. Connect an additional external supply to prevent pressure drop.
4. Check the brake disc temperature; it should be between 14°F and 122°F (-10°C and 50°C).
5. Push and pull caliper three times in the axial direction to assess any existing air gap. If no movement is possible, clean the disc brake and if necessary, replace the caliper guide pins. Refer to Section 1 & 2 of your New Flyer Service Manual for procedure. Once movement is obtained, continue to step 8.



**Removal of the adjuster cap with a screwdriver, or similar tool, is not allowed. Damage to the seal may result.**

6. Pull off the adjuster cap using the tag, taking care not to lose the shear adapter.



**Ensure that the brake chamber (service and parking/emergency) is not exerting any pressure on the brake caliper during this test.**

7. Push the brake caliper towards the middle of the vehicle.
8. Push brake lining away from tappets.
9. Check the gap between each of the whole tappet surface of both tappets using two feeler gauges simultaneously (feeler

gauges must be at least 200 mm long). Each gap must measure between 0.028 to 0.047" (0.7 to 1.2 mm). If the clearance deviates from the specified value, reset and recheck the clearance with new brake pads by proceeding to step 10.

10. Insert new brake pads. Refer to Section 1 & 2 of your New Flyer Service Manual for procedure.
11. Set the starting gap by turning the adjuster with the shear adapter backwards and then forwards until a value of 1.3 mm air gap has been achieved (measure between the brake pad and Tappets).

 **NOTE:**

*When turning backwards a noticeable clicking can be heard and felt.*

12. Apply the brakes 20 times with medium pressure (approximately 30 to 40 psi (2 to 3 bar)).
13. Check the gap between each of the tappets and inboard pad backplate. Each gap must measure between 0.028 to 0.047" (0.7 to 1.2 mm).

This must be measured over the whole tappet surface of both tappets using two feeler gauges simultaneously (feeler gauges must be at least 220 mm long). See ["Fig. 1: Measuring Tappet To Brake Pad Gap"](#) on page 3.

- a. If the air gap is larger than 1.2 mm, proceed to step 14.
- b. If the air gap is smaller than 6 mm, proceed to step 17.

Additionally, if the gap difference between the two tappets is greater than 0.25 mm then the caliper guide pin clearance must be checked. Refer to Section 1 & 2 of your New Flyer Service Manual for procedure. If the caliper guide pin play is within specification, then the tappets have lost synchronization and the caliper needs to be replaced.

14. If the air gap is larger than 1.2 mm the adjuster must be checked as follows:
- Turn the adjuster with adapter 3 clicks counter-clockwise (increasing the air gap).



**Make sure the wrench or socket can turn freely clockwise during the following procedure.**

- As a visual aid, position a wrench or socket onto the adjuster (including Adapter). Apply the brake 5 to 10 times (approximately 30 psi (2 bar)), the wrench or socket should turn clockwise (viewed from actuator side) in small increments if the adapter is functioning correctly. See "Fig. 2: Checking Adjuster Movement" on page 3.
  - As the number of applications increases, incremental movement of the wrench or socket will decrease. If the wrench or socket does not turn or turns only with the first application or turns forward and backward with every application, the automatic adjuster has failed and the caliper must be replaced.
15. Lightly grease the contact surface of the adjuster cap with white grease.

**NOTE:**

*A new adjuster cap should be fitted even if the brake pads are not being replaced.*

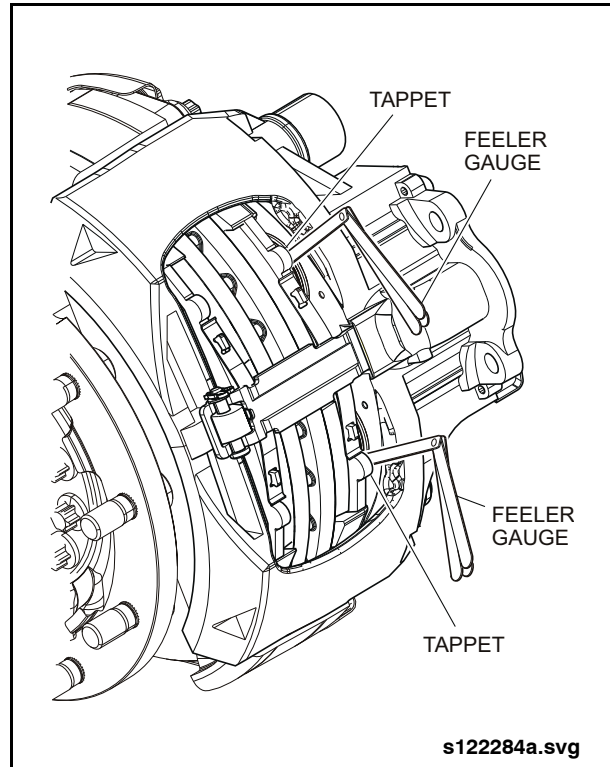

Fig. 1: Measuring Tappet To Brake Pad Gap

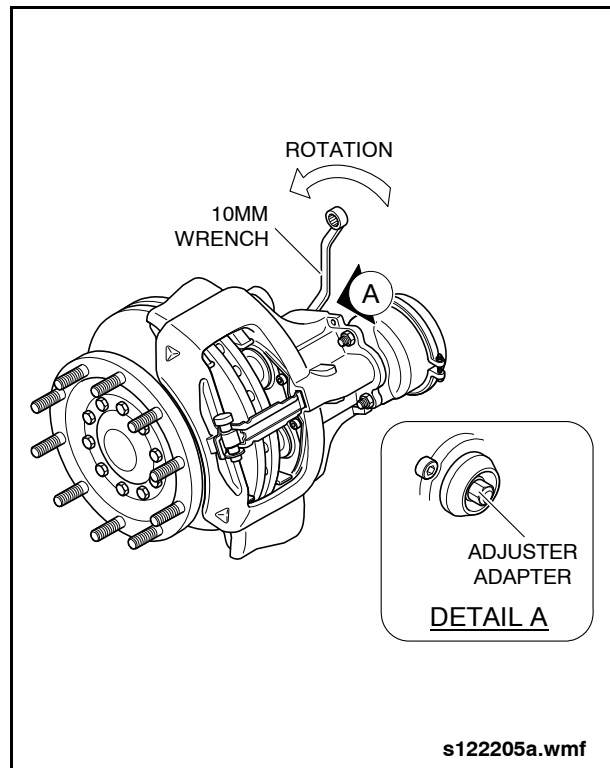

Fig. 2: Checking Adjuster Movement

16. The tag of the adjuster cap should be positioned to ensure access is maintained for subsequent removal.
17. If the air gap is smaller than 0.6 mm the parameters and functions must be checked as follows:
  - a. Apply the brakes to function the brake chamber.
  - b. Remove brake chamber. Refer to Section 1 & 2 of your New Flyer Service Manual for procedure.
  - c. Check position of lever inside the caliper in its released state.
  - d. Inspect the previously removed brake pads. If necessary, remove dirt from brake pads, caliper and carrier.
    - i. Check brake pads for wear from the tappets and if necessary replace brake pads.
      - ii. Check for abnormal wear of the contact areas of the carrier. If necessary replace the carrier.
- e. Check the brake disc.
18. Check caliper running clearance. Refer to Section 1 & 2 of your New Flyer Service Manual for procedure.
19. Install the brake pads. Refer to Section 1 & 2 of your New Flyer Service Manual for procedure.
20. Install the brake chamber. Refer to Section 1 & 2 of your New Flyer Service Manual for procedure.
21. Recheck the adjuster.
22. If the air gap is still smaller than 0.6 mm between both tappets, the brake caliper must be replaced.
23. Install the wheel.