



iNformation

Update Your MCS Software and MCI Tester

The current software update (MCS_2.013) for the MCS diagnostic tool was released on February 29, 2016. This latest software update supports diagnostic functions for all MCS compatible models released to date.

Make sure your MCS software and the MCI (diagnostic tool) are up to date for the latest models. Download the software update to your service department laptop PC from *iN* by following this path:

iN > ***Service*** > ***TechLine*** > ***Diagnostic Tools*** > ***MCS*** > ***Software Download***

All Models

2015 & Later Water Cooled Models

New Type 2 HP Coolant

Due to emerging environmental regulations, Honda Type 2 Blue coolant will now be “factory fill” in Powersports products, starting with model year 2015. Pro Honda Oils and Chemicals is pleased to introduce the state-of-the-art Type 2 formulation of HP Coolant.

This advanced new coolant is compatible with the previous generation green HP Coolant and replaces it for all applications, so there’s no problem if you need to mix them. Also good news; the price is lower than the previous formula. Available through normal parts channels:

Pro Honda HP Coolant, Type 2 (32 oz)
P/N 08C50-C321S02 (12 bottles/case)

Installing Engine Covers

Proper alignment is critical for engine covers on torque converter equipped engines, DCT type transmissions where the oil feed tubes could be damaged if the cover is not installed correctly; or an engine cover with a gear position switch which has to be indexed correctly and could be knocked out of alignment during the installation. Potential problems can be avoided by using a pair of guide pins installed on the engine-side of the assembly to ensure the cover goes on correctly. Guide pins can be easily fashioned from long case cover bolts by cutting off the head of the bolt and slotting the tip for a flat-blade screwdriver. Install the guide pins on opposite sides of the cover so that it is supported evenly. Use caution when installing alternator covers this way as the cover is magnetically attracted to the flywheel and may pinch your fingers.



On-Road

2016 GL1800

Decoding Trim Level by VIN

It is often necessary to know the area code and corresponding trim level of the GL1800 you’re working on in order carry out certain service procedures or when ordering replacement parts. The key to positively identifying trim level lies within

the unit's VIN. The following table identifies the trim level by the key letter in the VIN (in bold).

Although there are now ten "area code" types of GL1800 for model year 2016, as with past model years there are only four different trim levels.

VIN ID	Area Code	Equipment Package
JH2SC68 G *	2YA, 2AC, 4AC	Audio, Comfort
JH2SC68 H *	3YA, 3AC, 5AC	Audio, Comfort, Navi-XM
JH2SC68 N *	6YA, 6AC, 7AC	Audio, Comfort, Navi-XM, ABS
JH2SC68 Z *	9YA	Audio, Comfort, Navi-XM, ABS, Airbag

TRX & SXS

TRX 4WD Models 2000 & Later

Front Differential Slip Torque Inspection

Checking the differential slip torque allows you to assess the condition of the differential without having to disassemble it. However, the tool depicted in the *Differential Inspection* section of the Service Manual is not available from American Honda. The tool that is available in the U.S. (P/N 07KMK-HC5010A), looks like an almost square bar of steel that couldn't possibly fit into the female splines of the front drive unit. Yet it does as the trapezoid shape perfectly engages the female splines within the front differential.



Here's how to set-up the tools and measure the slip torque of a TRX front differential:

1. Choose the side of the tool that best fits the differential splines; "A" side is smaller than "B" side. In this example the "B" side fits the TRX420/500 differential shown here.
2. Clamp the parallel edges of the "A" side of the tool in a bench vise so that the "B" side sticks up about 60 mm as shown.

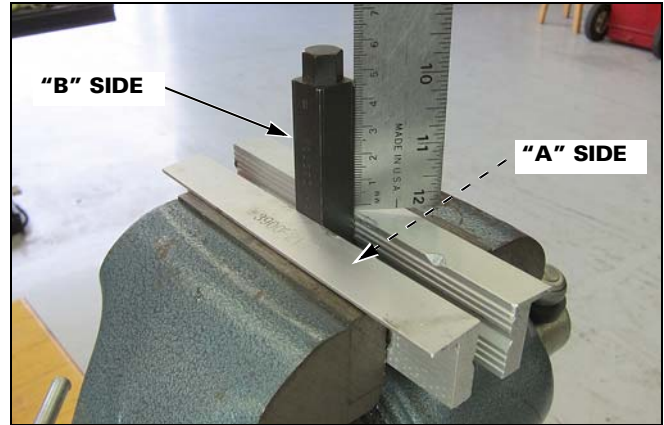

3. Install the differential assembly onto the "B" side of the tool as shown.



4. Install the "B" side of the second tool into the other side of the differential as shown.



5. Apply the torque wrench to the hex fitting on the end of the tool and check that the

differential slips somewhere between the lowest and highest value of the specified torque range.

STANDARD:

14 – 17 N·m (1.45 – 1.75 kgf·m, 10 – 13 lbf·ft)

SERVICE LIMIT:

12 N·m (1.2 kgf·m, 9 lbf·ft)



If the slip torque is out of specification, disassemble the differential and perform the components inspection as the differential may be faulty.

2014 & Later TRX420 - All,
2014 & Later TRX500 - All

**Engine Will Not Start,
Engine Starts - Then Stops**

Reports from the field indicate that a faulty bank angle sensor (BAS) is often to blame when the engine fails to start, or starts and then quits. There are also BAS failures that don't cause the engine to stop, but cause the MIL (check engine light) to flash. But, before troubleshooting the BAS specifically, check all the simple stuff like fuel level, engine stop switch, and battery voltage.

**Engine Starts & Runs and MIL is Flashing
"DTC 54"**

Confirm the Diagnostic Trouble Code (DTC) is "54" by counting five long blinks and four short blinks.

1. Unbolt the BAS from the frame and let it rest in its upright position on the frame.
2. Start the engine and let it run for at least 10 seconds.
3. With the engine running, invert the BAS and note whether the engine shuts off within 10 seconds.

- If the engine does not shut off, the BAS is faulty - replace it.
- If the engine shuts off within 10 seconds, the BAS is OK. Connect the MCS tester and proceed to troubleshoot for DTC 54-1 or 54-2 (Bank Angle Sensor Circuit) by following the procedure in the Service Manual.

Engine Will Not Start or Starts, Runs and Then Quits - No MIL Flashing

1. Disconnect the BAS connector from the BAS body and then start the engine.
 - If the engine starts and continues to run, the BAS is faulty - replace it.
 - If the engine does not start, proceed to troubleshoot the cause by following the SYMPTOM TROUBLESHOOTING table within the PGM-FI section of the appropriate Service Manual.

Bank Angle Sensor Location

The BAS is located on the frame just ahead and to the left of the steering shaft as shown. The Service Manual advises removing the front fender/carrier to access BAS, but it can be accessed by turning the handlebar fully to the right as shown.

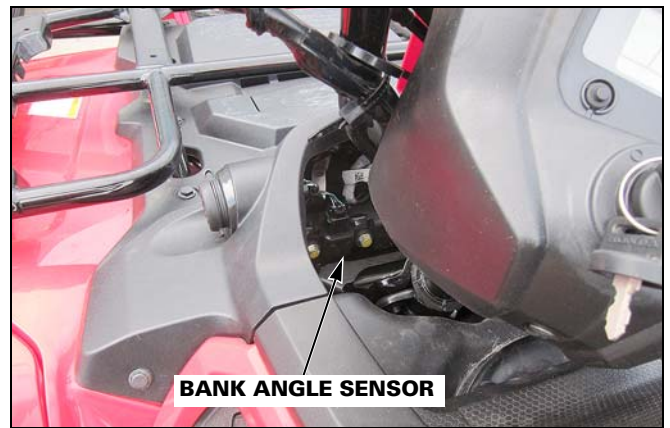

**New Style Driveshaft Joint
Boot and Band**

Starting with model year 2015, several TRX and all SXS models feature new super tough plastic CV joint boots on the drive shafts. The removal and installation of these new boots is easier than with previous designs, but requires new CV joint band pliers to install the boot bands. Be sure to refer to the Service Manual when servicing the CV joints on late-model TRX and SXS as each joint requires a unique boot and band combination. Also, the Service Manual outlines the correct installation

direction for the boot bands as well as the technique for using the boot band tool.



Make sure your service department is properly equipped. Order the new boot band pliers from the Honda Tool and Equipment Program by logging on to **iN** and following this path:

Service > Tools > Tool and Equipment Program

TRX420FA/FPA/FA1/FA2,
TRX500FA5/6/7

Oil Changing Tip

These models utilize a semi-dry sump oiling system where the oil tank is integrated into the crankcase. Because of this feature, when refilling the oil tank it appears that oil will come out of the filler hole before anything shows up on the dipstick. This is a normal condition as the oil needs to fill up to the top portion of the oil tank before it flows over the spill way and then down into the front crankcase cover where the dipstick is located.

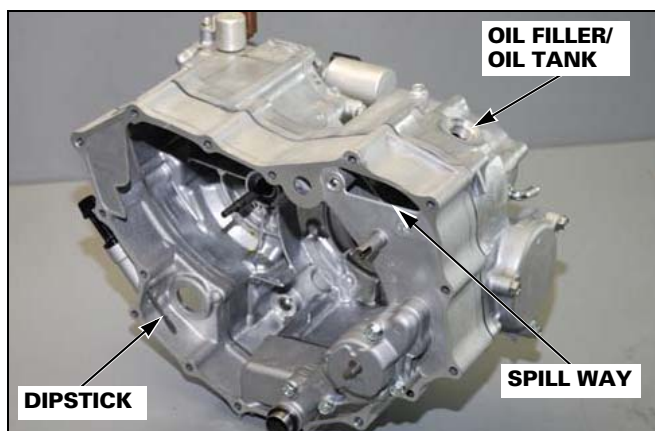

The best way to refill the oil on this machine is to pre-measure the amount of oil and slowly pour it into the engine. Once filled, run the engine for three to five minutes, turn it off and then check the oil level after waiting two or three minutes for the level to settle. Use the following volume specs, and the oil level should be spot-on.

Engine Oil Capacity:

TRX420FA1/2/5/6

TRX500FA5/6/7

3.6 qt after draining

3.8 qt after draining/filter change

SXS700 and SXS1000

Rear Seatbelt Retractor... Won't

If you're testing the rear seat belt retractor before it is mounted to the vehicle and you find the belt is stuck in its housing and won't pull out or retract, that's because it's designed to lock the belt when the vehicle tilts.

The rear seat belt retractor has an internal locking mechanism within the housing that will lock the belt if the housing is at an angle other than how it is normally mounted in the vehicle. If the belt gets stuck, hold the housing in the orientation that it would normally be mounted in the vehicle as shown. Then, feed a small amount of the belt back into its housing, then *gently* pull it back out. This should de-activate the locking mechanism and it should operate normally again. This method can also be used to free a customer's stuck seat belt.

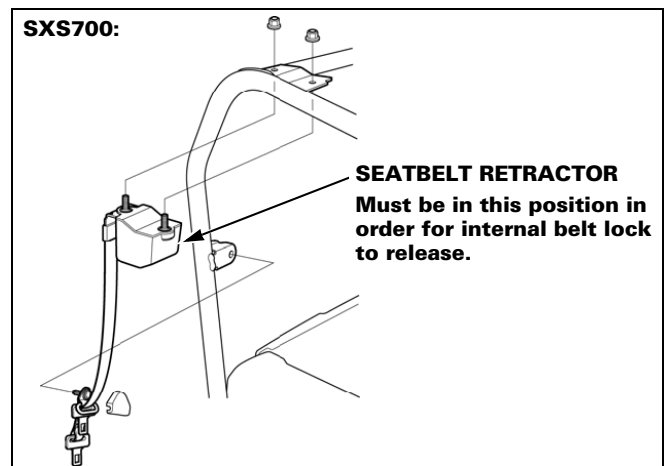

©2016 American Honda Motor Co., Inc. All Rights Reserved. Published by: AHM Motorcycle Service Communications, 1919 Torrance Blvd., Torrance, CA 90501. All suggestions become the property of American Honda Motor Co., Inc. Sending a suggestion gives American Honda permission to publish it without further consideration. *The information in this article is for authorized Honda PWC or MUV dealers only (applicable only if a PWC or MUV article is included in the issue).

Editor: Robert Heilbron E-mail *The Wrench* at EditorTheWrench@ahm.honda.com

MSN 15742 (1602)