

D/C Cut Fuse Installation During PDS

Service Category General

Section Pre-Delivery Service

Market USA

Lexus Supports
ASE Certification 

Applicability

YEAR(S)	MODEL(S)	ADDITIONAL INFORMATION
2017	LX570	

Introduction

To minimize battery discharge during transportation and storage, the D/C Cut Fuse has been removed at the assembly plant and temporarily stored in the engine compartment Relay Block. Reinstall the D/C Cut Fuse into its original location and confirm all related DTCs are cleared during Pre-Delivery Service (PDS).

Warranty Information

OP CODE	DESCRIPTION	TIME	OFB	T1	T2
N/A	Not Applicable to Warranty	–	–	–	–



D/C Cut Fuse Installation During PDS

Installation Procedure

1. Remove the D/C Cut Fuse (30A) from the blank space of the fuse block in the engine compartment and install it in the location shown below during PDS.

Figure 1.

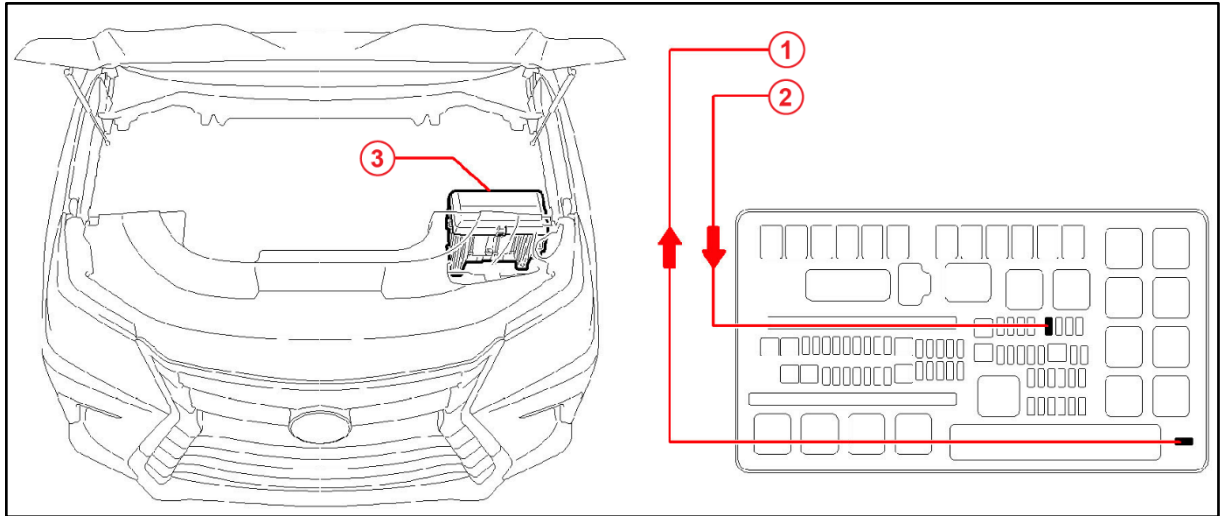

1	Remove This D/C Cut Fuse
2	Install D/C Cut Fuse (Original Location)

3	Relay Block
----------	-------------