

TECHNICAL BULLETIN
JTB00392NAS3
27 JUN 2016



© Jaguar Land Rover North America, LLC

NOTE: The information in Technical Bulletins is intended for use by trained, professional Technicians with the knowledge, tools, and equipment required to do the job properly and safely. It informs these Technicians of conditions that may occur on some vehicles, or provides information that could assist in proper vehicle service. The procedures should not be performed by 'do-it-yourselfers'. If you are not a Retailer, do not assume that a condition described affects your vehicle. Contact an authorized Jaguar service facility to determine whether this bulletin applies to a specific vehicle.

This reissue replaces all previous versions. Please destroy all previous versions.

Changes are highlighted in gray

SECTION: 303-14

Engine MIL Illuminated

AFFECTED VEHICLE RANGE:

XF (X250)

Model Year: 2013-2015
VIN: S47999-U88785 V6 S/C 3.0L Petrol /V8 S/C 5.0L Petrol
Assembly Plant: Castle Bromwich

F-TYPE (X152)

Model Year: 2014-2015
VIN: K06417-K22184 V6 S/C 3.0L Petrol /V8 S/C 5.0L Petrol
Assembly Plant: Castle Bromwich

XJ Range (X351)

Model Year: 2013-2015
VIN: V34128-V90865 V6 S/C 3.0L Petrol /V8 S/C 5.0L Petrol
Assembly Plant: Castle Bromwich

MARKETS:

NAS

CONDITION SUMMARY:

Situation: The engine Malfunction Indicator Lamp (MIL) may be illuminated. Upon diagnosis, the technician may find Diagnostic Trouble Codes (DTC) relevant to the mid-catalyst and post-catalyst heated oxygen sensors (HO2S) -- P0036, P0037, P0038, P0042, P0043, P0044, P0054, P0055, P0056, P0057, P0058, P0060, P0061, P0062, P0063, P0064, P0136, P013A, P013C, P013E, P0141, P0141, P0142, P0143, P0144, P0147, P014A, P0156, P0157, P0158, P0161, P0162, P0163, P0164, and/or P0167 -- stored in the Powertrain Control Module (PCM).

Cause: This may be caused by a post-catalyst heated oxygen sensor (HO2S) software error.



NOTE: Use DDW to check for Recall, Service Action, or Update Prior to Sale notice eligibility requiring a Powertrain Control Module (PCM) software update. If eligible, perform and claim the PCM update as per that program.

Action: Should a customer express this concern, follow the Service Instruction outlined below.

PARTS:

C2D23702	Heated Oxygen sensor - XF (X250), XJ (X351)	1
C2D23703	Heated Oxygen sensor - F-TYPE (X152), XF (X250), XJ (X351)	1
C2D24756	Heated Oxygen sensor - F-TYPE (X152), XF (X250), XJ (X351)	1
C2D24758	Heated Oxygen sensor - XF (X250), XJ (X351)	1
C2D27350	Heated Oxygen sensor - XF (X250), XJ (X351)	1
C2D39892	Heated Oxygen sensor - F-TYPE (X152), XF (X250), XJ (X351)	1

TOOLS:



NOTE: This Active Bulletin will display a functional programming shortcut if accessed within a diagnostic session.

Jaguar Land Rover-approved diagnostic tool with latest DVD and Calibration File

Jaguar Land Rover-approved Midtronics battery power supply

WARRANTY:

WARRANTY:



NOTE: Repair procedures are under constant review, and therefore times are subject to change; those quoted here must be taken as guidance only. Always refer to TOPIx to obtain the latest repair time.



NOTE: DDW requires the use of causal part numbers. Labor only claims must show the causal part number with a quantity of zero.



NOTE: Use DDW to check for Recall, Service Action, or Update Prior to Sale notice eligibility requiring a Powertrain Control Module (PCM) software update. If eligible, perform and claim the PCM update as per that program.

DESCRIPTION	SRO	TIME (hours)	CONDITION CODE	CAUSAL PART
Heated Oxygen Sensor (HO2S) - Pre-catalyst - Left bank - Renew - F-TYPE (X152; 3.0L SC V6)	18.31.64	1.3	04	C2D39892
Heated Oxygen Sensor (HO2S) - Pre-catalyst - Right bank - Renew - F-TYPE (X152; 3.0L SC V6)	18.31.65	1.3	04	C2D39892
Heated Oxygen Sensor (HO2S) - Mid-catalyst - Left bank - Renew - F-TYPE (X152; 3.0L SC V6)	18.31.61	1.1	04	C2D17259
Heated Oxygen Sensor (HO2S) - Mid-catalyst - Right bank - Renew - F-TYPE (X152; 3.0L SC V6)	18.31.60	1.1	04	C2D17259
Heated Oxygen Sensor (HO2S) - Pre-catalyst - Left bank - Renew - F-TYPE (X152; 5.0L SC V8)	18.31.64	1.3	04	C2D39892
Heated Oxygen Sensor (HO2S) - Pre-catalyst - Right bank - Renew - F-TYPE (X152; 5.0L SC V8)	18.31.65	1.3	04	C2D39892
Heated Oxygen Sensor (HO2S) - Mid-catalyst - Left bank - Renew - F-TYPE (X152; 5.0L SC V8)	18.31.61	1.2	04	C2D17259
Heated Oxygen Sensor (HO2S) - Mid-catalyst - Right bank - Renew - F-TYPE (X152; 5.0L SC V8)	18.31.60	1.2	04	C2D17259
Heated Oxygen Sensor (HO2S) - Post-catalyst - Auto trans - Renew - F-TYPE (X152)	18.31.67	0.3	04	C2D17259
Heated Oxygen Sensor (HO2S) - Post-catalyst - Manual trans - Renew - F-TYPE (X152)	18.31.67	0.5	04	C2D17259
Heated Oxygen Sensor (HO2S) - Pre-catalyst - Left bank - Renew - XF (X250; 3.0L SC V6; RWD)	18.31.64	0.7	04	C2D39892
Heated Oxygen Sensor (HO2S) - Pre-catalyst - Left bank - Renew - XF (X250; 3.0L SC V6; AWD)	18.31.64	0.7	04	C2D39892
Heated Oxygen Sensor (HO2S) - Pre-catalyst - Right bank - Renew - XF (X250; 3.0L SC V6)	18.31.65	0.8	04	C2D39892
Heated Oxygen Sensor (HO2S) - Mid-catalyst - Left bank - Renew - XF (X250; 3.0L SC V6; RWD)	18.31.61	0.5	04	C2D17259
Heated Oxygen Sensor (HO2S) - Mid-catalyst - Left bank - Renew - XF (X250; 3.0L SC V6; AWD)	18.31.61	0.5	04	C2D17259
Heated Oxygen Sensor (HO2S) - Mid-catalyst - Right bank - Renew - XF (X250; 3.0L SC V6)	18.31.60	0.6	04	C2D17259
Heated Oxygen Sensor (HO2S) - Pre-catalyst - Left bank - Renew - XF (X250; 5.0L SC V8)	18.31.64	0.7	04	C2D39892
Heated Oxygen Sensor (HO2S) - Pre-catalyst - Right bank - Renew - XF (X250; 5.0L SC V8)	18.31.65	0.8	04	C2D39892
Heated Oxygen Sensor (HO2S) - Mid-catalyst - Left bank - Renew - XF (X250; 5.0L SC V8)	18.31.61	0.5	04	C2D17259
Heated Oxygen Sensor (HO2S) - Mid-catalyst - Right bank - Renew - XF (X250; 5.0L SC V8)	18.31.60	0.6	04	C2D17259
Heated Oxygen Sensor (HO2S) - Post-catalyst - Renew - XF (X250)	18.31.67	0.5	04	C2D17259
Heated Oxygen Sensor (HO2S) - Pre-catalyst - Left bank - Renew - XJ (X351; 3.0L SC V6)	18.31.64	0.7	04	C2D39892
Heated Oxygen Sensor (HO2S) - Pre-catalyst - Right bank - Renew - XJ (X351; 3.0L SC V6)	18.31.65	0.8	04	C2D39892
Heated Oxygen Sensor (HO2S) - Mid-catalyst - Left bank - Renew - XJ (X351; 3.0L SC V6)	18.31.61	0.6	04	C2D17259

DESCRIPTION	SRO	TIME (hours)	CONDITION CODE	CAUSAL PART
Heated Oxygen Sensor (HO2S) - Mid-catalyst - Right bank - Renew - XJ (X351; 3.0L SC V6; RWD)	18.31.60	0.6	04	C2D17259
Heated Oxygen Sensor (HO2S) - Mid-catalyst - Right bank - Renew - XJ (X351; 3.0L SC V6; AWD)	18.31.60	0.6	04	C2D17259
Heated Oxygen Sensor (HO2S) - Pre-catalyst - Left bank - Renew - XJ (X351; 5.0L SC V8)	18.31.64	0.6	04	C2D39892
Heated Oxygen Sensor (HO2S) - Pre-catalyst - Right bank - Renew - XJ (X351; 5.0L SC V8)	18.31.65	0.7	04	C2D39892
Heated Oxygen Sensor (HO2S) - Mid-catalyst - Left bank - Renew - XJ (X351; 5.0L SC V8)	18.31.61	0.4	04	C2D17259
Heated Oxygen Sensor (HO2S) - Mid-catalyst - Right bank - Renew - XJ (X351; 5.0L SC V8)	18.31.60	0.4	04	C2D17259
Heated Oxygen Sensor (HO2S) - Post-catalyst - Renew - XJ (X351)	18.31.67	0.3	04	C2D17259
Read and clear Diagnostic Trouble Codes (DTC)	86.99.78	0.2	04	C2D30319
Configure existing PCM - F-TYPE (X152), XF (X250), XJ (X351)	86.99.26	0.2	04	C2D30319

DIAGNOSTIC TROUBLE CODE (DTC) INFORMATION:

Diagnostic Trouble Code (DTC) Table

Diagnostic Trouble Code (DTC)	Heated Oxygen sensor (HO2S)
P0036, P0037, P0038, P0054, P0136, P013A, P013E, P0141	Mid-catalyst - right bank (Heated Oxygen sensor [HO2S] - Right)
P0042, P0043, P0044, P0055, P0142, P0143, P0144, P0147	Post-catalyst - right bank (Heated Oxygen sensor [HO2S] - Right)
P0056, P0057, P0058, P0060, P013C, P014A, P0156, P0157, P0158, P0161	Mid-catalyst - left bank (Heated Oxygen sensor [HO2S] - Left)
P0062, P0063, P0064, P0162, P0163, P0164, P0167	Post-catalyst - left bank (Heated Oxygen sensor [HO2S] - Left)

COMPONENT LOCATION:

1. 
NOTE:
 3.0L SC V6 engine shown viewed from above; 5.0L SC V8 similar.

Heated Oxygen Sensor (HO2S) location and designation.

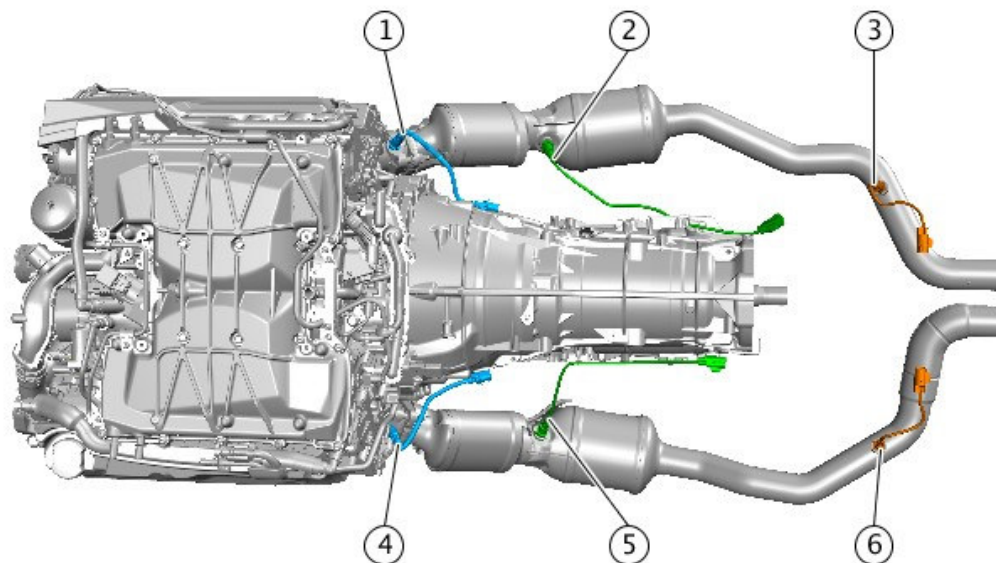

E181489

HO2S	DESCRIPTION	IDENTIFICATION
1	HO2S Heated Oxygen Sensor - Pre-catalyst - Bank 1, sensor 1	B1-S1

HO2S	DESCRIPTION	IDENTIFICATION
2	HO2S Heated Oxygen Sensor - Mid-catalyst - Bank 1, sensor 2	B1-S2
3	HO2S Heated Oxygen Sensor - Post-catalyst - Bank 1, sensor 3	B1-S3
4	HO2S Heated Oxygen Sensor - Pre-catalyst - Bank 2, sensor 1	B2-S1
5	HO2S Heated Oxygen Sensor - Mid-catalyst - Bank 2, sensor 2	B2-S2
6	HO2S Heated Oxygen Sensor - Post-catalyst - Bank 2, sensor 3	B2-S3

SERVICE INSTRUCTION:

 **CAUTION: A Jaguar Land Rover-approved Midtronics battery power supply must be connected to the vehicle-battery during diagnosis / module programming.**

 **CAUTION: Ensure all ignition ON / OFF requests are carried out; failure to perform these steps may cause damage to control modules in the vehicle.**

 **NOTE: The Jaguar Land Rover-approved diagnostic tool must be loaded with DVD146.00 v.241 or later.**

 **NOTE: Use DDW to check for Recall, Service Action, or Update Prior to Sale notice eligibility requiring a Powertrain Control Module (PCM) software update. If eligible, perform and claim the PCM update as per that program.**

1. Connect the Jaguar Land Rover-approved Midtronics battery power supply to the vehicle battery.
2. Turn ignition ON (engine not running).
3. Connect the Jaguar Land Rover-approved diagnostic tool to the vehicle and begin a new session.
4. Follow the on-screen prompts, allowing the diagnostic tool to read the VIN and identify the vehicle and initiating the data collect sequence.
5. Read the Diagnostic Trouble Codes (DTC).
6.  **NOTE: Only the affected Heated Oxygen sensor(s) should be replaced as indicated by the Diagnostic Trouble Code(s) (DTC) stored in the Powertrain Control Module (PCM); refer to Diagnostic Trouble Code (DTC) Table. It is very unlikely for both sensors to fail simultaneously. The new software will prevent any further concerns.**

Refer to Diagnostic Trouble Code (DTC) Table:

- If no listed DTC(s) is stored in the Powertrain Control Module (PCM), continue to the next step to update the PCM software.
- If one or more of the listed DTCs is stored in the PCM, replace only the relevant Heated Oxygen sensor(s) (HO2S) indicated by the stored DTC (see TOPIX Workshop Manual section 303-14).

- Once complete, continue to the next step to update the PCM software.

7. Turn ignition ON (engine not running).
8. Select **Diagnosis** from the Session Type screen.
9. Select the **Selected Symptoms** tab, and then select:
 - **Electrical > Instruments > Warning lamps > Engine malfunction lamp > Lamp illuminated**
10. Select **Continue**.
11. Select the **Recommendations** tab.
12. Select **Run** to perform the **Configure existing module - Powertrain control module** option.

13. Follow all on-screen instructions to complete this task, ensuring all DTCs are cleared.

14. Exit the current session.

15. Disconnect the diagnostic tool and battery power supply from the vehicle.