



Service Bulletin

File in Section: -

Bulletin No.: 16-NA-112

Date: April, 2016

INFORMATION

Subject: 2016 Cadillac CT6 New Model Features

Attention: United States, Canada and Mexico. This Bulletin also applies to Export vehicles. Export Countries Include: Europe, Israel, Japan, South Korea, Russia, Saudi Arabia.

Brand:	Model:	Model Year:		VIN:		Engine:	Transmission:
		From:	To:	From:	To:		
Cadillac	CT6	2016	2016	All	All	Gasoline, 4 CYL, L4, 2.0L, SIDI, DOHC, VVT, DCVCP, TURBO CHARGED — RPO LTG Gasoline, 6 CYL, V6, 3.0L, DI, DOHC, VVT, TWIN TURBO CHARGED — RPO LGW Gasoline, 6 CYL, V6, 3.6L, DI, DOHC, VVT — RPO LGX	Hydra-Matic 8L45, Automatic 8-Speed Transmission — RPO M5N Hydra-Matic 8L90, Automatic 8-Speed Transmission — RPO M5X

Overview



4468967

Bulletin Purpose

This is a special bulletin to introduce the 2016 Cadillac CT6. The purpose of this bulletin is to help the Service Department Personnel become familiar with some of the vehicle's new features and to describe some of the action they will need to take to service this vehicle.

Trim Levels

The 2016 CT6 is available in three trim levels, including:

- Premium
- Luxury
- Platinum

Overview

The CT6 will lead the Cadillac's nomenclature change and rides on GM's new rear-wheel drive Omega platform. GM's most advanced body manufacturing methods are used to fabricate the structure. The result is a car that in some configurations, weighs less than 3,700 lbs (1,678 kg) which for some perspective, is right in line with the smaller CTS.

Vehicle Highlights

Some of the vehicle highlights are:

The CT6 base engine is a responsive 2.0L (1,998 cc), sending 265 horsepower (198 kW) @ 5,500 RPM (Estimate) and 295 lb-ft (400 Nm) @ 3,000 - 4,300 RPM (Estimate) to the rear wheels with Engine Auto STOP/START technology.

The all-new V6 3.0L Twin Turbo is designed to achieve segment-leading thresholds of refinement and specific output. It is the only six-cylinder engine to combine turbocharging with cylinder deactivation and Engine Auto STOP/START technologies, to conserve fuel by an estimated 6 percent, over a comparable combination without the technologies. The 3.0L Twin Turbo features turbochargers with lightweight, low-inertia titanium-aluminide turbine wheels and an efficient, patented low-volume charge-air cooler, which contribute to optimal boost production and more immediate power delivery.

The all-new 3.6L V6 engine debuts in the 2016 model year, with new benchmarks for efficiency, refinement and durability. The clean-sheet engine redesign represents the fourth generation of GM's acclaimed DOHC V6 engine family and incorporates new features,

including Active Fuel Management (AFM) and Engine Auto STOP/START technology to enhance fuel economy. The new 3.6L also advances performance- and fuel economy-optimizing technologies introduced on previous generations, including direct injection and continuously variable valve timing.

Active-on-demand all-wheel drive (AWD) is also part of the Active Chassis System, making the most of handling and stability in all weather conditions. Its lightweight, compact design and two-gear transfer case enable greater fuel economy than conventional fixed torque AWD systems. AWD is standard on all CT6 V6 models. Selectable Tour, Snow/Ice and Sport modes allow the driver to tailor the CT6's advanced chassis system for practically any weather or road condition.

Active Rear Steering with the Active Chassis System contributes to greater low-speed agility and high speed stability. In parking lots, the turning circle is only 37 feet (11.4 m), comparable with the CTS, which has a 114.6-inch (2.91 m) wheelbase vs. the CT6's 122.4-inch (3.11 m) wheelbase.

The chassis system also balances responsiveness with segment-best isolation for exceptional refinement. In the front, the CT6 features a lightweight, aluminum-intensive high-arm multilink short/long arm front suspension. At the rear is a five-link independent suspension that uses multiple outer ball joints and cross braces for optimal handling and steering precision.

Extended comfort seats offer a refined, luxurious appearance. Features include premium Opus leather, five massage programs, reclining rear seats and Cadillac's first application of woven-in-seat heating elements.

Indirect Fire light-emitting diode front lighting system is standard and offers state of the art, more efficient illumination for a distinctive appearance.

An Articulating Rear Seat package offers new thresholds for comfort and luxury, with approximately 3.3 inches (83 mm) of adjustable seat travel, lumbar adjustment, tilting cushions, massage feature, heating/cooling features and armrest with media controls, including HDMI and USB ports.

Cadillac-first Bose® Panaray® audio system.

A large 10.2-inch (259 mm) diagonal Cadillac User Experience (CUE) interface screen.

18-inch, 19-inch and 20-inch wheels.

Quadzone Climate System.

Rear Camera Mirror.

Wireless phone charging and OnStar 4G LTE with Wi-Fi hotspot.

Brakes

This vehicle is equipped with a Bosch ABS 9.0 brake system. The electronic brake control module and the brake pressure modulator valve are serviced

separately. The brake pressure modulator valve uses a four circuit configuration to control hydraulic pressure to each wheel independently.

- **Antilock Brake System:** When wheel slip is detected during a brake application, an ABS event occurs. During ABS braking, hydraulic pressure in the individual wheel circuits is controlled to prevent any wheel from slipping. A separate hydraulic line and specific solenoid valves are provided for each wheel. The ABS can decrease, hold, or increase hydraulic pressure to each wheel. The ABS does not, however, increase hydraulic pressure above the amount which is transmitted by the master cylinder during braking.
- **Brake Assist:** The brake assist function is designed to support the driver in emergency braking situations. The EBCM receives inputs from the brake pressure sensor. When the EBCM senses an emergency braking situation, the EBCM will actively increase the brake pressure to a specific maximum.
- **Electronic Brake Distribution:** The electronic brake distribution function is designed to support the driver in emergency braking situations. The electronic brake distribution is a control system that enhances the hydraulic proportioning function of the mechanical proportioning valve in the base brake system. The electronic brake distribution control system is part of the operation software in the electronic brake control module. The electronic brake distribution uses active control with existing ABS in order to regulate the vehicle's rear brake pressure.
- **Hill Start Assist:** When stopped on a hill, the hill start assist feature prevents the vehicle from rolling before driving off, whether facing uphill or downhill by holding the brake pressure during the transition between when the driver releases the brake pedal and starts to accelerate. The electronic brake control module calculates the brake pressure, which is needed to hold the vehicle on an incline or grade greater than 5% and locks that pressure for up to two seconds by commanding the appropriate solenoid valves ON and OFF when the brake pedal is released. The stop lamps will stay illuminated during the hill start assist operation even though the brake pedal is released, this is considered normal operation.
- **Electronic Stability Control:** Electronic stability control provides added stability during aggressive maneuvers. Yaw rate is the rate of rotation about the vehicle's vertical axis. The stability control is activated when the EBCM determines that the desired yaw rate does not match the actual yaw rate as measured by the yaw rate sensor. The difference between the desired yaw rate and the actual yaw rate is the yaw rate error, which is a measurement of over steer or under steer. When a yaw rate error is detected, the EBCM attempts to correct the vehicle's yaw motion by applying brake pressure to one or more of the wheels. The amount of brake pressure which is applied varies, depending on the correction required.

- **Traction Control:** When drive wheel slip is noted, the EBCM will enter traction control mode. First, the EBCM requests the engine control module (ECM) to reduce the amount of torque to the drive wheels via a serial data message. The ECM reduces torque to the drive wheels and reports the amount of delivered torque. If the engine torque reduction does not reduce drive wheel slip, the EBCM will actively apply the brakes on the slipping drive wheel. During traction control braking, hydraulic pressure in each drive wheel circuit is controlled to prevent the drive wheels from slipping. The EBCM commands the pump motor and appropriate solenoid valves **ON** and **OFF** to apply brake pressure to the slipping wheel.
- **Automatic Vehicle Hold (RPO JM8):** Automatic Vehicle Hold (AVH) can be turned ON by pressing the AVH button with the driver safety belt fastened, the driver door closed, and the engine running. The AVH indicator will turn ON.

This feature will activate when the vehicle is stopped to prevent it from moving. After the brake pedal has been released and before the accelerator pedal has been pressed, AVH uses braking pressure to hold the vehicle stationary. In addition, the ABS pump motor may activate to build brake pressure to maintain the vehicle at a standstill if necessary.

If AVH is holding the vehicle, the AVH indicator will change to green. Once AVH is active it will hold the vehicle for a defined time period then engage the parking brake. While AVH is holding the vehicle, the parking brake will engage if the driver door is opened or the driver safety belt is unfastened.

Ferritic Nitro Carburized Rotors — Calipers

Application of the FNC technology involves an additional manufacturing process that heats the rotors at 1,040°F (560°C) for up to 24 hours in a giant oven. Inside the nitrogen-rich atmosphere, nitrogen atoms bond to the surface of the steel rotor, hardening and strengthening the rotor. This hardened layer allows the rotor to wear slower and reduces rotor corrosion.

Front Rotors — RPO J55 (2.0L Turbo): Ferritic Nitro Carburized vented rotors, 12.6 inch (321 mm) with Brembo four piston aluminum fixed calipers.

Front Rotors — RPO J56 (3.0L Twin Turbo and 3.6L): Ferritic Nitro Carburized vented rotors, 13.6 inch (345 mm) with Brembo four piston aluminum fixed calipers.

Rear Rotors — RPO J55 & J56) (All Models): Ferritic Nitro Carburized vented rotors, 12.4 inch (315 mm) with single piston cast-iron sliding calipers.

Engines

2.0L L4 Turbocharged Engine

Performance from GM's Ecotec family of engines continues to advance with the 2.0L Turbo and is based on a generation of large displacement four cylinder engines which are designed for greater efficiency. The 2.0L has Engine Auto Stop/Start technology to

conserve fuel. The turbocharger generates up to 20 pounds (138 kPa) of boost and its twin-scroll design helps optimize the usable power from the engine, virtually eliminating turbo lag and helping deliver a broad power band. It also gives the engine the rapid throttle responsiveness associated with a higher displacement naturally aspirated high performance engine. Electronically controlled supporting components, including the wastegate and bypass, help optimize performance and efficiency.

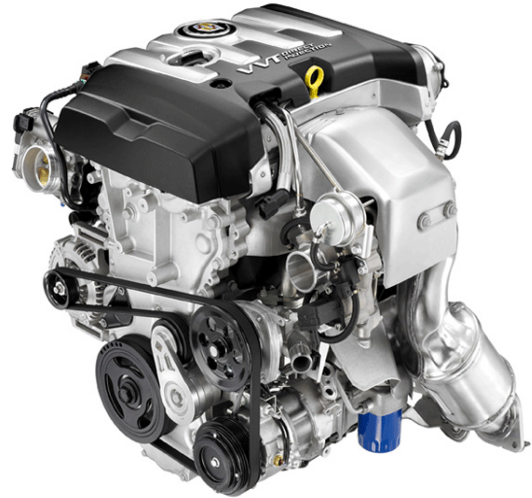

4474621

Shown is a typical view of the 2.0L L4 turbocharged engine — RPO LTG .

Engine Component Description and Operation

- **Cam Driven High Pressure Fuel Pump:** A high-pressure, cam driven pump provides the fuel pressure required by the direct injection system. The engine mounted fuel pump is augmented by a conventional electrically operated supply pump in the fuel tank. The fuel delivery system features a high-pressure stainless steel feed line and a pressure regulated fuel rail without a conventional fuel return line from the engine to the tank. Fuel pressure varies from about 750 psi (5,171 kPa) at idle to 2,250 psi (15,513 kPa) at wide-open throttle.
- **Cylinder Head and Valves:** The engine has an A356T6 aluminum cylinder head that is cast using a Rotocast process for high strength, reduced machining and improved port flow and is designed specifically for direct injection (DI). The head is also designed specifically for direct injection. The head has unique injector mounting locations below the ports. The head uses stainless steel intake valves that are nitrided for improved durability and undercut to improve flow and reduce weight. The exhaust valves have sodium-filled stems that promote valve cooling. At normal engine operating temperatures, the sodium inside the valve stem fuses and becomes liquid. The liquid sodium improves conductivity, promoting

heat transfer away from the valve face and valve guide to the cooler end of the stem, where it more readily dissipates. This helps maintain a lower, more uniform valve temperature, reducing wear on the valve guide for better alignment and a consistent seal between the valve seat and valve face over the life of the engine. The exhaust manifold is mounted to the cylinder head and made of cast stainless steel. It is extremely durable and delivers exceptional airflow qualities.

- **Direct Injection:** Direct injection (DI) moves the point where fuel feeds into an engine closer to the point where it ignites, enabling greater combustion efficiency. It fosters a more complete burn of the fuel in the air-fuel mixture, and operates at a lower temperature than conventional port injection. This allows the mixture to be leaner (less fuel and more air), so less fuel is required to produce the equivalent horsepower of a conventional, port-injection fuel system. DI also delivers reduced emissions, particularly cold start emissions, by about 25 percent. The fuel system operates at pressures as high as 2,250 psi (15,513 kPa) compared to about 60 psi (414 kPa) in conventional port-injected engines.
- **Cylinder Block:** The Ecotec 2.0L turbo sand-cast cylinder block is a superior refinement of previous Ecotec engine block castings. It is dimensionally similar with previous Ecotec turbo block variants, while providing improved structural support, as well as enabling greater control of noise, vibration and harshness. The main bearing bulkheads, which support the crank bearings, as well as the cylinder bore walls have been significantly strengthened to support increased engine loads. Refinements to the oil distribution system enable improved oil flow throughout the engine and an expansion of the coolant jacket, along with the use of cast-in-place bore liners, allows more precise bore roundness and improves the block's ability to dissipate heat.
- **Rotating Assembly:** The crankshaft is made of drop forged steel with induction heat-treated fillets and cross-drilled chamfered oil passages for racing grade lubrication characteristics. Forged powdered metal connecting rods incorporate a larger, forged I-beam cross section for added strength in this turbocharged application. The pistons are lightweight cast aluminum, which reduces reciprocating mass inside the engine and enhances efficiency. The tops of the pistons have a dish shape that deflects injected fuel. Each piston has its own directed jet that sprays oil toward its skirt, coating its underside and the cylinder wall with an additional layer of lubricant. The extra lubrication cools the pistons, reduces both friction and operational noise and bolsters the engine's durability.
- **Two-Stage Variable Displacement Oil Pump:** The variable-flow oiling system helps maximize fuel efficiency. Rather than the linear operation of a conventional fixed-flow pump, it is accomplished with a crankshaft-driven oil pump that matches the oil supply to the engine load. The engine's variable-flow pump changes its capacity based on

the engine's demand for oil. This prevents using energy to pump oil that is not required for proper engine operation. An engine oil cooler helps maintain optimum oil temperatures. It has a heat exchanger incorporated into the oil filter housing. Coolant to the heat exchanger is provided by the engine's coolant circuit. The design optimizes oil cooling with a minimal pressure loss. During cold starting, the system also enables faster heating of the engine oil for an earlier reduction of internal engine friction.

- **Twin Scroll Turbocharger and Air-to-Air Intercooler:** An advanced, electronically controlled turbocharger with a unique twin scroll design is used to increase power in the 2.0L. Each of two scrolls on the turbine is fed by a separate exhaust passage, one from cylinders one and four, the other from cylinders two and three which virtually eliminates turbo lag at low engine speeds, giving the engine immediate throttle response associated with a naturally aspirated high performance engine. The turbocharger generates maximum boost of about 20 psi (138 kPa). Because DI cools the intake process compared to port injection, it allows the 2.0L turbo to safely operate at higher boost and a relatively higher compression ratio (9.2:1) than a conventional turbo engine, increasing both output and efficiency. An intake charge cooler enhances the power-increasing benefits of the turbocharging system. The air-to-air intercooler draws fresh air through a heat exchanger, much like a radiator, to reduce the temperature of compressed air that's forced through the intake system by the turbocharger. Inlet temperature is reduced as much as 180°F (100°C). Cooler air is denser, which means more oxygen is packed in the cylinders for optimal combustion and, consequently, greater power.
- **Vacuum Pump:** A cam driven vacuum pump ensures the availability of vacuum under all conditions, especially under boost, when the engine produces the opposite of vacuum. The pump is mounted at the rear of the cylinder head and is driven by the exhaust camshaft via a flexible coupling.

Engine Specifications

- **Displacement:** 2.0L (122 cubic inches)
- **Bore x Stroke :** 3.38 inches (86 mm) x 3.38 inches (86 mm)
- **Compression Ratio:** 9.5:1
- **Horsepower:** 265 hp (198 kW) @ 5,500 RPM (Estimate)
- **Maximum Engine Speed:** 7,000 RPM
- **Torque:** 295 lb-ft (400 Nm) @ 3,000–4,300 RPM (Estimate)
- **Valves:** 2 intake and 2 exhaust valves per cylinder
- **Valve Lifters:** Hydraulic roller finger follower
- **Recommended Fuel:** Premium unleaded.

3.0L V6 Twin Turbocharged Engine

The all-new 3.0L V6 Twin Turbo is designed to achieve segment-leading thresholds of refinement and specific output. It is the only six-cylinder engine to combine turbocharging with cylinder deactivation and Engine Auto Stop/Start technologies to conserve fuel by an estimated 6 percent, over a comparable combination without the technologies. The 3.0L Twin Turbo features turbochargers with lightweight, low-inertia titanium-aluminide turbine wheels and an efficient, patented low-volume charge-air cooler, which contribute to optimal boost production and more immediate power delivery.



4475103

Shown is a typical view of the 3.0L V6 Engine — RPO LGW

Engine Component Description and Operation

- **Active Fuel Management System (AFM):** The AFM consists of the camshafts, valves, the switching roller finger followers (SRFF), also known as the valve switching rocker arm, the dual feed hydraulic lash adjusters and the oil control valve (OCV) which is also known as the valve rocker arm oil control valve.

Depending on engine RPM, the ECM sends a signal to the OCV commanding it either **ON** or **OFF**.

With the AFM system **ON**, the OCV directs oil to the dual feed hydraulic lash adjuster unlatching the switching roller finger followers creating zero lift and not allowing the valves to open on cylinders two and five. AFM is active at this time.

With the AFM system **OFF**, the OCV is not active and no oil is directed to the dual feed hydraulic lash adjuster. The switching roller finger followers operate as normal rocker arms. AFM is inactive at this time.

- **Camshaft Position Actuator System:** The engine incorporates a camshaft position actuator for each intake and exhaust camshaft. Camshaft

phasing changes valve timing as engine operating conditions vary. Dual camshaft phasing allows the further optimization of performance, fuel economy and emissions without compromising overall engine response and driveability. Variable valve timing also contributes to a reduction in exhaust emissions. It optimizes exhaust and inlet valve overlap and eliminates the need for an exhaust gas recirculation (EGR) system. The camshaft position actuator is a hydraulic vane-type actuator that changes the camshaft lobe timing relative to the camshaft drive sprocket. Engine oil is directed by a camshaft position actuator oil control valve to the appropriate passages in the camshaft position actuator. Oil acting on the vane in the camshaft position actuator rotates the camshaft relative to the sprocket. The camshaft position actuator oil control valve (OCV) directs oil from the oil feed in the head to the appropriate camshaft position actuator oil passages. There is one OCV for each camshaft position actuator. The OCV is sealed and mounted to the front cover. The ported end of the OCV is inserted into the cylinder head with a sliding fit. A filter screen protects each OCV oil port from any contamination in the oil supply.

- **Camshaft Drive System:** The camshaft drive system consists of two timing drive chains driven by the crankshaft which drives the respective cylinder head's intake and exhaust camshaft position actuators. Cushioned actuator chain sprockets have been added contributing to quieter engine operation. The timing drive chains use moveable timing drive chain guides and a hydraulic-actuated tensioner. The tensioner minimizes timing drive chain noise and provides accurate valve action by keeping slack out of the timing drive chains and continuously adjusting for timing drive chain wear. The tensioner incorporates a plunger that adjusts out with wear allowing only a minimal amount of backlash. All tensioners are sealed to the head or block using a rubber coated steel gasket. The gasket traps an adequate oil reserve to ensure quiet start-up.
- **Connecting Rod and Piston:** The connecting rods are forged titanium alloy and have press-in-place piston pin bushings. The connecting rods and rod cap are aligned by dowel pins retained in the cap. The cast aluminum pistons incorporate a polymer coated skirt to reduce friction. The pistons are unique to the LGW both for compression ratio and combustion efficiency. The piston uses two low tension compression rings and one multi-piece oil control ring.
- **Cooling System:** This engine has a targeted cooling system which sends coolant simultaneously to each water jacket in the heads and block. This new, parallel-flow design maximizes heat extraction in the area of the upper deck, intake and exhaust valve bridges in the heads and integrated exhaust manifold with a minimal amount of coolant. The result is more even and consistent cooling, which enhances

performance, and faster engine warm up, which improves cold-start efficiency and reduces emissions.

- **Crankshaft:** The crankshaft is a hardened, forged steel design with 4 main bearings. Crankshaft thrust is controlled by the upper portion of the number 3 main bearing. The crankshaft position reluctor wheel is pressed onto the rear of the crankshaft in front of the rear main journal. A micro encapsulated adhesive is used on the reluctor wheel to aid retention. The crankshaft is internally balanced.
- **Cylinder Block:** The cylinder block is unique to the LGW due to the need for specific turbocharger oil and coolant connections and PCV flow and is constructed of aluminum alloy by precision sand-casting with cast in place iron cylinder liners. Each nodular main bearing cap incorporates 6 bolts bolting the cap into the engine block. Along with 2 outer and 2 inner bolts, 2 side bolts are used in the deep skirt block. To prevent aeration, oil return from the valve train and cylinder heads is channeled away from the rotating and reciprocating components through oil drain back passages incorporated into the cylinder heads and engine block. Pressure-actuated piston oil cooling jets are mounted between opposing cylinders. Twin knock sensors are located in the valley of the block between the cylinder heads. The knock sensors have an acoustic foam noise barrier that surrounds them in the valley.
- **Cylinder Head:** The cylinder heads are a two piece design consisting of a head and a camshaft carrier which are cast aluminum with powdered metal valve seat inserts and valve guides. The two piece design allows for the Active Fuel Management (AFM) System. The cylinder heads also feature integrated exhaust manifolds; the exhaust manifolds are incorporated into the head casting. Two intake valves and two exhaust valves are actuated by roller finger followers pivoting on a stationary hydraulic lash adjuster (SHLA). In the LGW engine, the valves and seats are constructed with specialized materials and coatings, and the exhaust valves are sodium filled for robustness with the high temperature turbocharged environment. The cylinder heads also feature a "high-tumble" port design, and are sealed with LGW specific head gaskets. The head gaskets are also specific to the LH and RH sides. Separate exhaust and intake camshafts are supported by bearings machined into the camshaft carrier. The front camshaft bearing cap is used as a thrust control surface for each camshaft. Each spark plug is shielded by a tube that is pressed into the cylinder head. Each spark plug ignition coil is also mounted through the spark plug tube. The LGW engine uses specific spark plugs and a different spark plug gap from other HFV6 engines. The engine coolant temperature (ECT) sensor is mounted in the thermostat housing near the flywheel end of the engine. With direct injection, the high pressure injectors are located in machined bores below the intake ports. A stainless steel, high pressure fuel rail is attached to the intake side of the head. The LGW engine has unique higher-flow injectors and fuel pump. The cylinder head has a larger bore for the new larger diameter fuel pump follower that operates the higher-flow pump. The fuel injectors are retained to the fuel rail in a new "twist-lock" retention scheme that does not require special tools for service.
- **Oiling System:** The LGW engine contains a unique engine oil cooler and filter adapter for the specific needs of the turbocharged engine. This engine also features a dual-pressure control and variable-displacement vane pump that enhances efficiency by optimizing oil pressure as a function of engine speed. The oil pump is located beneath the cylinder block inside the oil pan, contributing to the engine's smoother and quieter operation. The oiling system components differ depending on the engine being in a transverse or longitudinal orientation. The LGW has unique oil pans depending on orientation, with the pans being separated into an upper (traditional aluminum) and lower (stamped steel) pan. This configuration helps with noise and mass concerns. It also affords some serviceability improvements through not needing to remove the entire upper pan for some service procedures; the procedures can be performed through removing the lower pan. The LGW oil pans contain oil level switches as do nearly all HFV6 applications. The oil level switch is normally open and closes at oil levels above minimum requirements.
- **Twin Turbochargers:** The LGW twin turbocharged engine is capable of up to 18 pounds (124 kPa) of boost. The turbocharger use a lightweight titanium aluminide turbine wheel that allows them to spool up quicker. Heat shields cover both turbochargers to protect nearby components. Two wastegates, one per turbocharger, regulate the boost pressure of the engine. The twin turbochargers are controlled by vacuum-actuated wastegate valves, which are in turn controlled by an electronic vacuum regulation valve and a vacuum control solenoid valve. A mechanical vacuum pump mounted on the right-hand cylinder head provides vacuum to a vacuum accumulator. Vacuum-actuated recirculation valves, or bypass valves, are also used in the system. The recirculation valves activate under high boost conditions when the driver quickly lets off the throttle, redirecting some of the boost pressure back into the compressor section of the turbocharger.

The charge air cooler module cools and combines the air from the twin turbochargers and directs the airflow to the single throttle body. The inlet from each turbo flows through one of the two air-to-liquid charge air cooler heat exchangers. This integrated charge air cooling system reduces the length of the pipes in the system and improves response time.
- **Vacuum Pump:** The engine utilizes a mechanical vacuum pump to provide a vacuum source for the braking system and turbocharger waste gate actuators. The vacuum pump is integrated into the

oil pump assembly located in the oil pan. Both vacuum pump and oil pump are part of a common assembly, referred to as a tandem pump. Neither pump is serviceable individually. If either the oil pump or vacuum pump are defective, replace the entire tandem pump assembly.

Engine Specifications

- **Displacement:** 3.0 L (182 cubic inches)
- **Bore x Stroke :** 3.38 inches (86 mm) x 3.377 inches (85.8 mm)
- **Compression Ratio:** 9.8:1
- **Horsepower:** 404 horsepower (301 kW) @ 5700 RPM (SAE Certified)
- **Maximum Engine Speed:** 6,500 RPM
- **Torque:** 400 lb-ft. (542 Nm) @ 2500–5100 RPM (SAE Certified)
- **Valves:** 2 intake and 2 exhaust valves per cylinder
- **Recommended Fuel:** Premium unleaded.

3.6L V6 Engine

The 3.6L V6 engine ushers in new benchmarks for efficiency, refinement and durability. The clean-sheet engine redesign represents the fourth generation of GM's acclaimed DOHC V6 engine family and incorporates new features, including Active Fuel Management (AFM) also known as cylinder deactivation and Engine Auto Stop/Start technology to enhance fuel economy. The 3.6L also advances performance and fuel economy, optimizing technologies introduced on previous generations, including direct injection (DI) and continuously variable valve timing (VVT).



4473946



4439358

Shown are typical views of the 3.6L V6 Engine — RPO LGX

Engine Component Description and Operation

- **Active Fuel Management System:** The Active Fuel Management System (AFM) consists of the camshafts, valves, the switching roller finger followers (SRFF), also known as the valve switching rocker arm, the dual feed hydraulic lash adjusters and the oil control valve (OCV) which is also known as the valve rocker arm oil control valve.

Depending on engine RPM, the ECM sends a signal to the OCV commanding it either **ON** or **OFF**.

With the AFM system **ON**, the OCV directs oil to the dual feed hydraulic lash adjuster unlatching the switching roller finger followers creating zero lift and not allowing the valves to open on cylinders two and five. AFM is active at this time.

With the AFM system **OFF**, the OCV is not active and no oil is directed to the dual feed hydraulic lash adjuster. The switching roller finger followers operate as normal rocker arms. AFM is inactive at this time.

- **Camshaft Drive System:** The camshaft drive system consists of two timing drive chains driven by the crankshaft which drives the respective cylinder head's intake and exhaust camshaft position actuators. Cushioned actuator chain sprockets have been added contributing to quieter engine operation. The timing drive chains use moveable timing drive chain guides and a hydraulic-actuated tensioner. The tensioner minimizes timing drive chain noise and provides accurate valve action by keeping slack out of the timing drive chains and continuously adjusting for timing drive chain wear. The tensioner incorporates a plunger that adjusts out with wear allowing only a minimal amount of backlash. The

tensioners are sealed to the head or block using a rubber coated steel gasket. The gasket traps an adequate oil reserve to ensure quiet start-up.

- **Camshaft Position Actuator System:** The engine incorporates a camshaft position actuator for each intake and exhaust camshaft. Camshaft phasing changes valve timing as engine operating conditions vary. Dual camshaft phasing allows the further optimization of performance, fuel economy and emissions without compromising overall engine response and driveability. Variable valve timing also contributes to a reduction in exhaust emissions. It optimizes exhaust and inlet valve overlap and eliminates the need for an exhaust gas recirculation (EGR) system.

The camshaft position actuator is a hydraulic vane-type actuator that changes the camshaft lobe timing relative to the camshaft drive sprocket. Engine oil is directed by a camshaft position actuator oil control valve to the appropriate passages in the camshaft position actuator. Oil acting on the vane in the camshaft position actuator rotates the camshaft relative to the sprocket. At idle, both camshafts are at the default or "home" position. At this position, the exhaust camshaft is fully advanced and the intake is fully retarded to minimize valve overlap for smooth idle. In addition, this engine has intermediate park technology, which incorporates an intermediate-lock intake variable valve timing cam phaser, allowing the cams to be parked at the most favorable position for cold starting. Under other engine operating conditions, the camshaft position actuator is controlled by the engine control module (ECM) to deliver optimal intake and exhaust valve timing for performance, driveability and fuel economy. The camshaft position actuator incorporates an integral trigger wheel, which is sensed by the camshaft position sensor mounted in the front cover, to accurately determine the position of each camshaft. The exhaust camshaft position actuator has a different internal configuration than the intake camshaft position actuator since the exhaust camshaft position actuator phases in the opposite direction relative to the inlet camshaft position actuator.

The camshaft position actuator oil control valve (OCV) directs oil from the oil feed in the head to the appropriate camshaft position actuator oil passages. There is one OCV for each camshaft position actuator. The OCV is sealed and mounted to the front cover. The ported end of the OCV is inserted into the cylinder head with a sliding fit. A filter screen protects each OCV oil port from any contamination in the oil supply.

- **Cooling System:** This engine has a targeted cooling system which sends coolant simultaneously to each water jacket in the heads and block. This new, parallel-flow design maximizes heat extraction in the area of the upper deck, intake and exhaust valve bridges in the heads and integrated exhaust manifold with a minimal amount of coolant. The result is more even and consistent cooling, which enhances

performance, and faster engine warm up, which improves cold-start efficiency and reduces emissions.

- **Connecting Rods and Pistons:** The connecting rods are sinter-forged with a high copper content and have press-in-place piston pin bushings. The connecting rods and rod cap are aligned by dowel pins retained in the cap. The cast aluminum pistons incorporate a polymer-coated skirt to reduce friction. The pistons are unique to the LGX both for compression ratio and combustion efficiency. The piston uses two low tension compression rings and one multi-piece oil control ring.
- **Crankshaft:** The crankshaft is a hardened, forged steel design with 4 main bearings. Crankshaft thrust is controlled by the upper portion of the number 3 main bearing. The crankshaft position reluctor wheel is pressed onto the rear of the crankshaft in front of the rear main journal. A micro encapsulated adhesive is used on the reluctor wheel to aid retention. This crankshaft is internally balanced.
- **Cylinder Block:** Stronger, stiffer aluminum block with increased structure in the bulkheads for superior rigidity.
- **Cylinder Heads:** The cylinder heads are a two piece design consisting of a head and a camshaft carrier which are cast aluminum with powdered metal valve seat inserts and valve guides. The two piece design allows for the Active Fuel Management (AFM) System. The cylinder heads also feature integrated exhaust manifolds; the exhaust manifolds are incorporated into the head casting. Two intake valves and two exhaust valves are actuated by roller finger followers pivoting on a stationary hydraulic lash adjuster (SHLA). In the LGX engine, the valves and seats are constructed with specialized materials and coatings, and the exhaust valves are sodium filled for robustness. The cylinder heads also feature a "high-tumble" port design, and are sealed with LGX specific head gaskets. The head gaskets are also specific to the LH and RH sides.

Separate exhaust and intake camshafts are supported by bearings machined into the camshaft carrier. The front camshaft bearing cap is used as a thrust control surface for each camshaft. Each spark plug is shielded by a tube that is pressed into the cylinder head. Each spark plug ignition coil is also mounted through the spark plug tube. The LGX engine uses specific spark plugs and a different spark plug gap from other HFV6 engines. The engine coolant temperature (ECT) sensor is mounted in the thermostat housing near the flywheel end of the engine. With direct injection, the high pressure injectors are located in machined bores below the intake ports. A stainless steel, high pressure fuel rail is attached to the intake side of the head. The LGX engine has unique higher-flow injectors and fuel pump. The cylinder head has a larger bore for the new larger diameter fuel pump follower that operates the higher-flow pump. The fuel injectors

are retained to the fuel rail in a new “twist-lock” retention scheme that does not require special tools for service.

- **Fuel Injectors and Spark Plugs:** The injector angle was changed to 24 degrees from 22 degrees to reduce emissions and oil dilution. A smaller 12 mm spark plug, down from 14 mm, enables the plug to be located closer to the center of the combustion chamber. This improves the flames propagation and increases light load efficiency.
- **Oiling System:** The LGX engine contains a dual-pressure control and variable-displacement vane pump that enhances efficiency by optimizing oil pressure as a function of engine speed. The oil pump is located beneath the cylinder block inside the oil pan, contributing to the engines smoother and quieter operation. The oiling system components differ depending on the engine being in a transverse or longitudinal orientation. The LGX has unique oil pans depending on orientation, with the pans being separated into an upper (traditional aluminum) and lower (stamped steel) pan. This configuration helps with noise and mass concerns. It also affords some serviceability improvements through not needing to remove the entire upper pan for some service procedures; the procedures can be performed through removing the lower pan. The LGX oil pans contain oil level switches as do nearly all HFV6 applications. The oil level switch is normally open and closes at oil levels above minimum requirements.
- **Right and Left Bank Designation:** Right hand (RH) and left hand (LH) designation throughout the engine mechanical section are viewed from the rear, flywheel side, of the engine or from inside the vehicle. These banks are also referred to as Bank 1 (RH) and Bank 2 (LH).
- **Vacuum Pump:** The engine utilizes a mechanical vacuum pump to provide a vacuum source for the braking system. The vacuum pump is integrated into the oil pump assembly located in the oil pan. Both vacuum pump and oil pump are part of a common assembly, referred to as a tandem pump. Neither pump is serviceable individually. If either the oil pump or vacuum pump are defective, replace the entire tandem pump assembly.

Engine Specifications

- **Displacement:** 3.6 L (220 cubic inches)
- **Bore x Stroke :** 3.74 inches (95 mm) x 3.37 inches (85.6 mm)
- **Compression Ratio:** 11.5:1
- **Horsepower:** 335 horsepower (250 kW) @ 6,800 RPM (SAE Certified)
- **Maximum Engine Speed:** 7,200 RPM
- **Torque:** 284 lb ft (385 Nm) @ 5,300 RPM (SAE Certified)
- **Valves:** 2 intake and 2 exhaust valves per cylinder
- **Recommended Fuel:** Regular unleaded.

Engine Oil — dexos®



3512027



3511747

Ask for and use engine oils that meet the dexos® specification. Engine oils that have been approved by GM as meeting the dexos® specification are marked with either of the dexos1® approved logos that are shown. For additional information, visit this General Motors website: <http://www.gmdexos.com>

Viscosity Grade

Use ACDelco dexos1® synthetic blend SAE 5W-30 viscosity grade engine oil. In an area of extreme cold, where the temperature falls below -20°F (-29°C) use SAE 0W-30 engine oil. An oil of this viscosity grade will provide easier cold starting for the engine at extremely low temperatures.

Engine Oil Life System

The vehicle features GM's engine oil life system, which better protects engines by recommending oil changes based on a computer software algorithm using actual engine operating conditions and can save the vehicle owner money by avoiding unnecessary oil changes.

Engine Auto Stop/Start

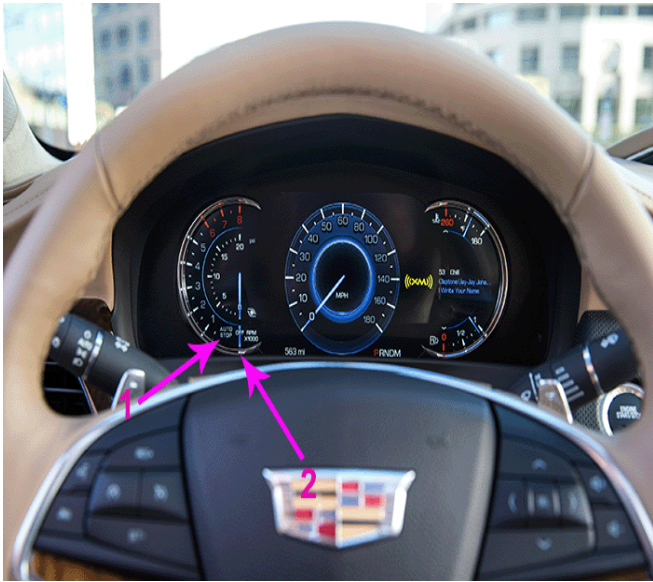

4477223

Typical view of a Tachometer on an Engine Auto Stop/Start equipped vehicle.

A fuel-saving Engine Auto Stop/Start system has been integrated with the 2.0L, 3.0L and 3.6L engine. While driving, when the brake pedal is applied and the vehicle is at a complete stop, the Engine Auto Stop/Start system may turn the engine **OFF**, depending on operating conditions. When the engine is **OFF**, the tachometer will read **AUTO STOP (1)**. Upon releasing the brake pedal or applying the accelerator pedal, the engine will restart. After parking the vehicle and turning the engine **OFF**, the tachometer will read **OFF (2)**.

An upgraded starter motor and advanced battery technology support the increased number of engine starts. The starter motor has a high performance electric motor and stronger pinion engagement mechanism. The starter motor has also been re-designed to reduce the noise on startup. Advanced battery technology ensures it can handle frequent charge and discharge cycles. An intelligent battery sensor module monitors the state of charge and health of the battery. Battery state of charge and health are used by the ECM to determine if the Stop/Start function may be performed.

The engine may remain running or restart if:

- A minimum vehicle speed is not reached.
- The engine or transmission is not at the required operating temperature.
- The outside (ambient) temperature is not in the required operating range.
- The shift lever is in any gear other than **D** (Drive).

- The battery charge is low.
- The current settings for the climate control (HVAC) or defog system have not been reached.
- The **AUTO STOP** time is greater than 2 minutes.

Head-Up Display (HUD)

If equipped with HUD, some information concerning the operation of the vehicle is projected onto the windshield. The image is projected through the HUD lens on top of the instrument panel. The information appears as an image focused out toward the front of the vehicle.

The HUD may display some of the following vehicle information and vehicle messages or alerts:

- Audio
- Collision Alert
- Cruise Control
- Lane Keep Assist
- Low Fuel
- Navigation
- Phone
- Speed
- Tachometer
- Temporary information, such as audio changes and navigation maneuvers, may also be displayed.

HUD Control Panel



4483672

The HUD control panel is to the left of the steering wheel. To adjust the HUD image:

1. Adjust the driver seat.
2. Start the engine.
3. Press the **HUD** button down or lift it up to center the HUD image. The HUD image can only be adjusted up and down, not side to side.

4. To select the information display view, press the **INFO** button to select from four displays, Speed, Audio/Phone, Navigation, and Performance. Each press will change the display view.
5. To adjust the brightness of the image, lift the **brightness** button up and hold to brighten the display. Press the button down and hold to dim the display. Hold the button down to turn the display **OFF**. The HUD image will automatically dim and brighten to compensate for outside lighting.

Instrument Panel Cluster — Driver Information Center

Instrument Panel Cluster - Base



4483450

The CT6 Instrument Panel Cluster (IPC) - Base, comes standard with an array of gauges. The IPC provides the driver with important vehicle information at a glance. The base cluster consists of a speedometer, tachometer, temperature gauge, oil pressure gauge, battery voltage and fuel gauge.

Instrument Panel Cluster - LCD Uplevel



4485093

The IPC LCD Uplevel, comes standard with an array of information options, readouts and gauges depending on the configuration selected by the driver.

Instrument Panel Cluster - LCD Uplevel Enhanced Configuration



4483482

The IPC LCD Uplevel features two configurations, Enhanced and Balanced.

Instrument Panel Cluster - LCD Uplevel Balanced Configuration



4483620

Driver Information Center

The Driver Information Center (DIC) is located in the bottom center of the Base IPC and is integrated into the Uplevel IPC. The DIC provides the driver with information, such as trip / fuel information, including fuel range, average fuel economy, average vehicle speed, and odometer readings. The DIC provides the status of many vehicle displays. The DIC also shows warning and status messages.

OnStar® with 4G LTE and Wi-Fi

With OnStar® 4G LTE and Wi-Fi, up to seven devices such as smartphones, tablets and laptops can be connected to high-speed Internet through the vehicle's built-in Wi-Fi hotspot.

To retrieve the SSID and password for the hotspot, press the OnStar® Voice Command button on the overhead console or rearview mirror, wait for the prompt, and then say "Wi-Fi Settings." The information will be displayed on the screen.

The powerful OnStar® connection also enables improved access to existing OnStar® safety and security services, including the ability to transmit voice and data simultaneously. That means OnStar® advisors can run a diagnostic check without ever leaving the call, making customer interactions quicker and more seamless. It's the most comprehensive in-vehicle safety and connectivity system available.

For assistance, press the blue OnStar® button or call 1-888-4-ONSTAR (1-888-466-7827).

Radio — Cadillac User Experience

The CT6 is equipped with a large 10.2-inch (259 mm) diagonal Liquid Crystal Display (LCD) CUE interface screen with 1280 x 720 HD resolution. The capacitive-touch screen reacts faster when scrolling and recognizes handwriting for address/points of

interest search. The touchpad allows control of CUE features while resting an arm on the center console rather than touching the screen.

Proximity-sensing technology detects the operator's hand as it approaches the touch screen. When viewing a map, controls become visible when a hand approaches the screen and fade out when the hand is removed. You can use simple gestures on the touch screen just as you would on a tablet, such as tap, drag, pinch and spread, to interact with the system. Touch an application icon on the touch screen to access an item. Link a smartphone, cell phone, USB flash drive or portable audio player/iPod® to the infotainment display using a Bluetooth or USB connection.

When using the Surround Vision, a true 360-degree camera view around the vehicle is displayed on the CUE screen and this helps to reduce blind spots around the vehicle.

For assistance in the United States, call 1-855-4-CUE-NOW (1-855-428-3669) or visit www.cadillac.com/cue

In Canada, visit www.cadillaccanada.ca/cadillac-cue-infotainment-system.html (English) or <http://fr.cadillaccanada.ca/cadillac-cue-infotainment-system.html> (French)

Cadillac CUE Features



4476198

CUE in the CT6 offers:

- **Text Message Alerts:** Text message alerts play a text message over the audio system and allow a response with a preset message. The text messaging feature must be set up when the cell phone is paired. Messages can be viewed on the touch screen only when the vehicle is not moving.
- **Voice Recognition:** Control the music source and navigation destination, and make phone calls hands-free (after pairing your Bluetooth® enabled phone), using the natural voice recognition system.

- **Voice Pass-Thru:** Voice pass-thru/Siri® Eyes Free allows access to the voice recognition commands on a cell phone; i.e. Siri® or Voice Command.
- **Gesture Recognition:** Tap, drag, pinch and spread, to interact with the system.
- **App Tray Customization:** Select and prioritize Favorite Apps.
- **Customizable Favorites:** Display the Favorite screen buttons.
- **Center Stack Integration:** CUE is seamlessly integrated into the center stack.
- **Navigation:** Map coverage available in the United States and Canada.

Bose® Panaray® System

- First introduction of Bose® Panaray® system for Cadillac.
- First to use Bose VideoWave®, Articulated Array® & line array speakers in an automotive environment.
- 0.31 x 2.76 in (8x70 mm) VideoWavespeakers with 1,001 cubic inches (16.4 Liter) of Bass box integrated into the floor.
- 34 Speakers strategically integrated relative to the occupants, of which 33 are 3.94 in (100 mm) or less in size.
- New Digital Sound Processor – nearly double the processing power.



4483965

- Moving IP Center Array.

Active Noise Cancellation

The 2016 Cadillac CT6 comes standard with active noise cancellation. The active noise cancellation system is a method used to reduce the perception of certain undesirable sounds generated by the engine and audible in the vehicle cabin. The system uses microphone and engine speed signals, software integrated into the amplifier, and the vehicle speakers to determine and generate the correct frequencies needed to achieve the desired noise reduction.

Safety — Airbag System

Airbag Readiness Light

This light illuminates and stays **ON** if there is an electrical problem with the airbag system. The system check includes the airbag sensors, passenger sensing system, the pretensioners, the airbag modules, the wiring, and the crash sensing and diagnostic module (SDM). The airbag readiness light turns **ON** for several seconds when the vehicle is started. If the light does not turn **ON** and then **OFF**, have it repaired immediately.

Airbag Locations

All vehicle airbags have the word AIRBAG on the trim or on a label near the deployment opening. The airbags are located in the following positions:

- A frontal airbag for the driver.
- A frontal airbag for the front outboard passenger.
- A knee airbag for the driver.
- A knee airbag for the front outboard passenger.
- Seat-mounted side impact airbag for the driver.
- Seat-mounted side impact airbag for the front outboard passenger.
- A roof-rail airbag for the driver and the passenger seated directly behind the driver.
- A roof-rail airbag for the front outboard passenger and the passenger seated directly behind the front outboard passenger.

Safety — Driving/Parking Assistance Systems

If equipped, the Rear Vision Camera (RVC), Rear Parking Assist (RPA), Front Parking Assist (FPA), Surround Vision, Front Vision Camera, Rear Automatic Braking (RAB) and Backing Warning System, Rear Cross Traffic Alert (RCTA), Automatic Parking Assist (APA) and Night Vision may help the driver park and/or avoid objects, pedestrians and animals.

- **Adaptive Cruise Control:** If equipped with Adaptive Cruise Control (ACC), it allows the driver to select the cruise control set speed and following gap. The following gap is the following time between your vehicle and a vehicle detected directly ahead in your path, moving in the same direction. If no vehicle is detected in your path, ACC works like regular cruise control.
- **Automatic Parking Assist:** If equipped, the Automatic Parking Assist (APA) system helps to search for and maneuver the vehicle into parallel or perpendicular parking spots using automatic steering, DIC displays, and beeps while the driver follows text commands, selects the gear and brakes/accelerates.
- **Backing Warning and Rear Automatic Braking:** Vehicles with Adaptive Cruise Control (ACC) have the Backing Warning System and Rear Automatic Braking (RAB) system. The Backing Warning part of this system can warn of rear objects when backing up at speeds greater than 5 mph (8 km/h).

The Backing Warning System will beep once from the rear when an object is first detected, or pulse twice on both sides of the Safety Alert Seat. When the system detects a potential crash, beeps will be heard from the rear, or five pulses will be felt on both sides of the Safety Alert Seat. There may also be a brief, sharp application of the brakes. Rear Automatic Braking may not avoid many types of backing crashes. Do not wait for the automatic braking to apply. This system is not designed to replace driver braking and only works in **R** (Reverse) when an object is detected directly behind the vehicle.

- **Forward Collision Alert:** If equipped, the FCA system may help to avoid or reduce the harm caused by front-end crashes. When approaching a vehicle ahead too quickly, FCA provides a red flashing alert on the windshield and rapidly beeps or pulses the driver seat. FCA also lights an amber visual alert if following another vehicle much too closely. FCA detects vehicles within a distance of approximately 197 ft (60 m) and operates at speeds above 25 mph (40 km/h). If the vehicle has Adaptive Cruise Control (ACC), it can detect vehicles to distances of approximately 360 ft (110 m) and operates at all speeds.
- **Front Automatic Braking:** If the vehicle has Forward Collision Alert (FCA), it also has Front Automatic Braking (FAB), which includes Intelligent Brake Assist (IBA). When the system detects a vehicle ahead in your path that is traveling in the same direction that you may be about to crash into, it can provide a boost to braking or automatically brake the vehicle. This can help avoid or lessen the severity of crashes when driving in a forward gear. Depending on the situation, the vehicle may automatically brake moderately or hard. This front automatic braking can only occur if a vehicle is detected. This is shown by the FCA vehicle ahead indicator being lit.
- **Front Vision Camera:** If equipped, a view of the area in front of the vehicle displays in the center stack. The view displays after shifting from **R** (Reverse) to a forward gear, or by pressing CAMERA in the center stack, and when the vehicle is moving forward slower than 5 mph (8 km/h). If equipped, the front view camera also displays when the Front Parking Assist system detects an object within 12 in (30 cm).
- **Intelligent Brake Assist:** If the vehicle has Forward Collision Alert (FCA), it also has FAB, which includes Intelligent Brake Assist (IBA). Intelligent Brake Assist (IBA) may activate when the brake pedal is applied quickly by providing a boost to braking based on the speed of approach and distance to a vehicle ahead. Minor brake pedal pulsations or pedal movement during this time is normal and the brake pedal should continue to be applied as needed. IBA will automatically disengage only when the brake pedal is released.
- **Lane Change Alert with Side Blind Zone Alert:** Lane Change Alert (LCA) provides outside side-mirror alerts to help the driver avoid crashing into a moving vehicle detected in their side blind spot (or zone) or a vehicle that is rapidly approaching their blind spot during a lane change maneuver.
- **Lane Keep Assist with Lane Departure Warning:** Lane Keep Assist (LKA) provides gentle steering wheel turns and Lane Departure Warning (LDW) alerts, if necessary to help drivers avoid crashes due to unintentionally drifting out of their lane when they are not actively steering and their turn signal is not activated.
- **Parking Assist:** If equipped, Rear Parking Assist (RPA) uses sensors on the rear bumper to assist with parking and avoiding objects while in **R** (Reverse). It operates at speeds of less than 5 mph (8 km/h). RPA may display a warning triangle on the Rear Vision Camera screen and a graphic on the instrument cluster to provide the object distance. In addition, multiple beeps or seat pulses may occur if very close to an object.
- **Rear Cross Traffic Alert:** If equipped, RCTA displays a red warning triangle with a left or right pointing arrow on the RVC screen to warn of traffic coming from the left or right. This system detects objects coming from up to 65 ft (20 m) from the left or right side of the vehicle. When an object is detected, either three beeps sound from the left or right or three Safety Alert Seat pulses occur on the left or right side, depending on the direction of the detected vehicle.
- **Rear Vision Camera:** When the vehicle is shifted into **R** (Reverse), the Rear Vision Camera (RVC) displays an image of the area behind the vehicle in the center stack display. A warning triangle may display on the RVC screen to show that it has detected an object. This triangle changes from amber to red and increases in size the closer the object becomes. The previous screen displays when the vehicle is shifted out of **R** after a short delay.
- **Safety Alert Seat:** The Safety Alert Seat provides the driver the option of getting haptic seat-bottom vibration crash avoidance alerts or beeping. To change from one to the other, see Collision/Detection Systems under Vehicle Personalization in the Owner Manual.



4477361

- Night Vision System:** If equipped, this system can help the driver see and alert the driver to pedestrians or large animals ahead of the vehicle beyond the area lit by the headlamps. A thermal heat image of the view ahead is displayed when it is dark enough outside. If a pedestrian or large animal is detected more than 82 ft (25 m) away, an amber pedestrian or animal icon displays and a box appears around the pedestrian or animal. When the system detects that the vehicle is approaching a pedestrian ahead much too quickly, the amber box changes to red. With the Front Pedestrian Braking system turned ON, Night Vision provides a red Head-Up Display (HUD) alert when the system detects that the vehicle is approaching a pedestrian ahead much too quickly.

Safety — Rear Camera Mirror with Streaming Video



4446638

Cadillac's patented new industry-leading **Rear Camera Mirror** system debuts on the CT6. The system enhances the driver's rear vision by an estimated 300 percent, using a video display applied over the conventional inside rearview mirror. A high-dynamic range camera records wider images behind the car, streams the image to video processing software which **removes** obstacles such as the roof, rear pillars and rear seat passengers, projecting an unobstructed view to a Liquid Crystal Display.

Thanks to a high dynamic range, the camera's video feed reduces glare and allows a crisper image in low-light situations, versus a traditional glass electrochromatic, or auto-dimming, rearview mirror. The in-mirror display is an industry-leading 1280 by 240-pixel TFT-LCD display with 171-pixels per inch, combined with a HD camera designed specifically to enhance rear view lane width and maximize low-light situations. A water-shedding hydrophobic coating is applied to the camera to keep it clean to maintain visibility regardless of the driving conditions.

Drivers can disable the mirror's video streaming function by flipping the toggle on the underside of the mirror. This will revert it to a traditional electrochromatic rearview mirror.

Streaming Video Mirror Vision Zone

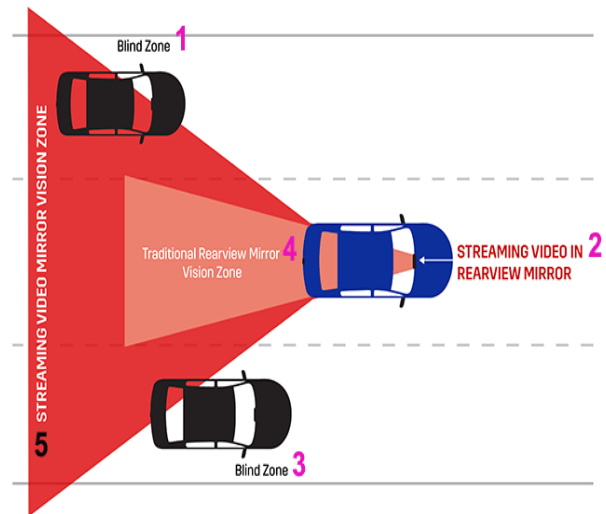

4446663

1. Blind Zone.
2. Streaming Video in Rearview Mirror.
3. Blind Zone.
4. Traditional Rearview Mirror Vision Zone.
5. Streaming Video Mirror Vision Zone

Rear Camera Mirror — Camera Location



4479192

The camera that provides the Rear Camera Mirror image is above the license plate, next to the Rear Vision Camera (RVC).

Safety — Surround Vision and Triggered Video Recording

Surround Vision

Notice: The Surround Vision cameras have blind spots and will not display all objects near the corners of the vehicle. Folding side mirrors that are out of position will not display the surround view correctly.

Surround Vision displays an image of the area surrounding the vehicle, along with the front or rear camera views in the center stack. The front camera is in the grille or near the front emblem, the side cameras are on the bottom of the outside rearview mirrors, and the rear camera is above the license plate.

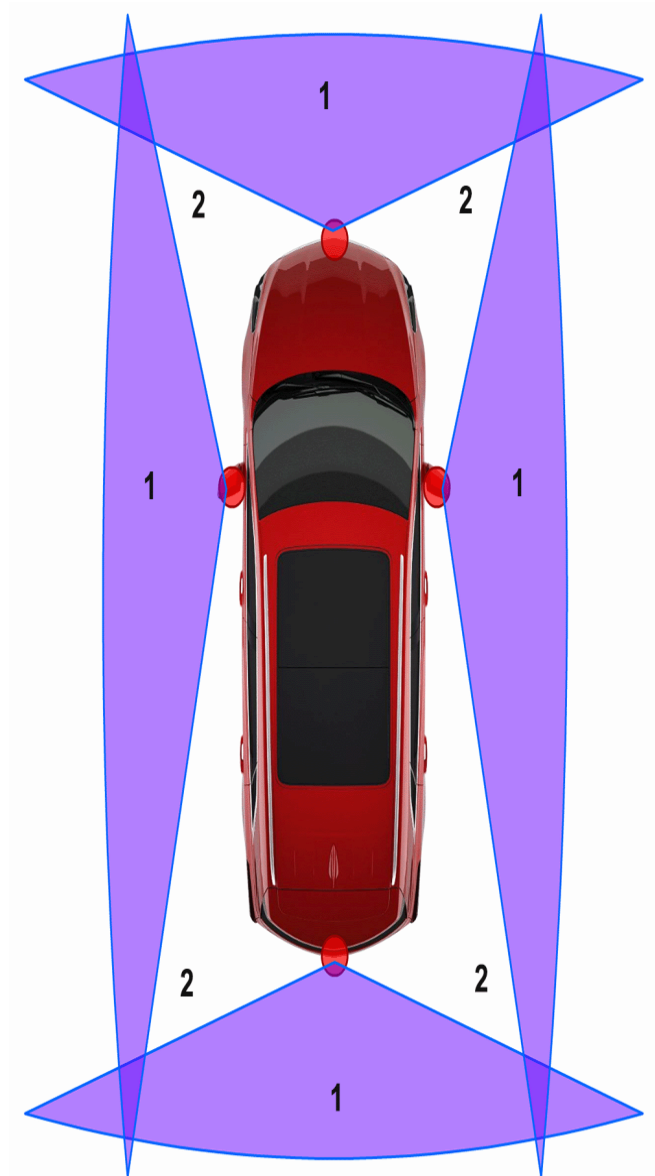

4451337

1 = Areas displayed by the Surround Vision cameras.

2 = Areas not displayed by the Surround Vision cameras.

Triggered Video Recording

In select markets, the CT6 will be equipped with the world’s first surround view integrated video recorder. Called “Triggered Video Recording”, the feature enables the vehicle’s four-camera, 360-degree camera/recording capability – an enabler to gathering information relating to traffic/security events. Playback is via the CT6’s 10.2-inch (259 mm) CUE display.

The system records the 360° camera views to an SD card. Only images are recorded, no sound. An SD card will be needed for this system. The recommended SD card is an 8-32GB SDHC card with FAT32 file system, Class 4 and over.

Insert the SD card into the card reader located in the trunk. Opening the trunk will disable recording to safely remove the SD card. Other files should not be stored on the same SD card as the surround vision recorder files. Storing other files on the same card may increase recording start up and playback time or result in a loss of data. There are approximately 12 hours of video storage based on an 8GB SD card. This could vary based on exterior lighting conditions. The recorded video is stored in five minute long files.

Steering — Active Rear Steering

Overview

The Cadillac CT6 is equipped with an electric power steering system that uses a rack-mounted electric motor. This type of system maximizes driveability and directional stability, which helps ensure the driver's comfort and safety. The electric power steering system provides steering assist to the driver by using an electric motor rather than a conventional hydraulic power steering pump. The power steering control module uses a combination of inputs from the torque sensor and motor rotational sensor, as well as vehicle speed, to determine the amount of assist required to steer the vehicle.

Active Rear Steering

Active Rear Steering (ARS) is standard on the Platinum edition and offered as an option on the Luxury and Premium vehicles. This will be part of the Active Chassis package. The ARS system improves low-speed maneuverability and increases agility at higher speeds. At low speeds, the rear wheels will turn in the opposite direction of the front wheels. The system allows the rear wheels to turn in unison with the front wheels at higher speeds, which helps the vehicle change direction much better. The result is a full-size car that handles like a mid-size sports sedan.

Active Rear Steering Smart Actuator

The ARS system consists of a smart actuator that contains the control module and motor and the linkage that transmits the force from the actuator to the rear steering knuckle and wheels. The ARS system is controlled by the electronic brake control module (EBCM), which uses inputs including vehicle speed, steering wheel angle sensor, and steering wheel angle rate of change to determine the correct rear wheel steering angle. The EBCM uses the Chassis GMLAN bus to command the Rear Wheel Steering Control Module (RWSCM) to turn the rear wheels. The RWSCM provides feedback to the EBCM over the Chassis GMLAN bus for the steering position and rate of change. The ARS system can mechanically move 4.6° but the controller limits movement to 3.5°. Below 22.3 mph (36 km/h) the rear wheels are turned out of phase with the front wheels in both forward and reverse. Above 22.3 mph (36 km/h) the rear wheels steer in phase with the front wheels.

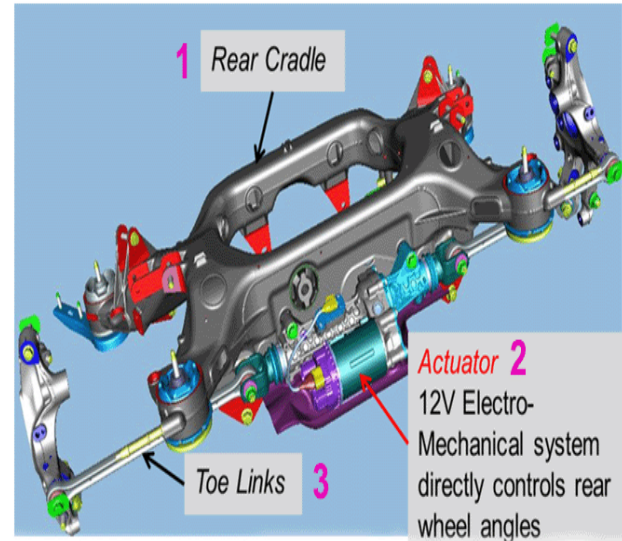

4482176

1. **Rear Cradle**
2. **Actuator:** 12V Electro-mechanical actuator directly controls rear wheel angles
3. **Toe Links**

Structure

For the CT6, engineers developed new body construction techniques and technologies allowing various types of advanced and lightweight materials to be combined within the manufacturing environment, including proprietary aluminum spot welding technology that is more efficient and helps reduce weight. Laser welding, flow drill fasteners and self-piercing rivets are also employed, along with roughly 591 feet (180 meters) of advanced structural adhesives. Thirteen high-pressure aluminum die castings in the lower body construction reduce complexity and are significant contributors to the architecture's low mass. The CT6 has all aluminum exterior body panels.

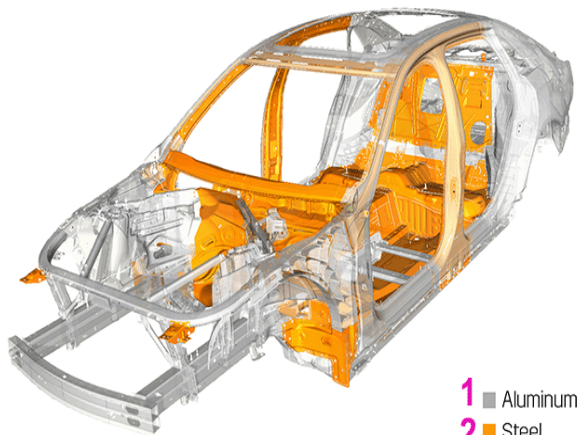

4484853

- 1 = Aluminum
- 2 = Steel

Suspension

Electronic Suspension Control System

The 2016 Cadillac CT6 is available with electronic suspension control. The rigid body structure firmly resists twisting forces and provides a solid foundation for the front and rear frames and the suspension system. The CT6 offers selectable-mode magnetic ride control that utilizes magneto-rheological technology. The vehicle has 3 modes which are Tour, Sport and Snow / Ice that are user selectable and change the characteristics of the suspension system. The electronic suspension control system utilizes the latest generation in magneto rheological technology to independently control each of the shock absorbers and struts. Magneto-rheological technology independently controls the fluid viscosity in each strut and shock absorber. Front struts and rear shock absorbers contain an internal electrical coil and micron-sized metal particles in the magneto-rheological fluid. The suspension control module uses pulse width modulated (PWM) current to the electric coil within each strut or shock. The PWM current increases the fluid viscosity by aligning the metal particles within it, which increases or decreases the suspension damping force during both compression and rebound.

Front Suspension

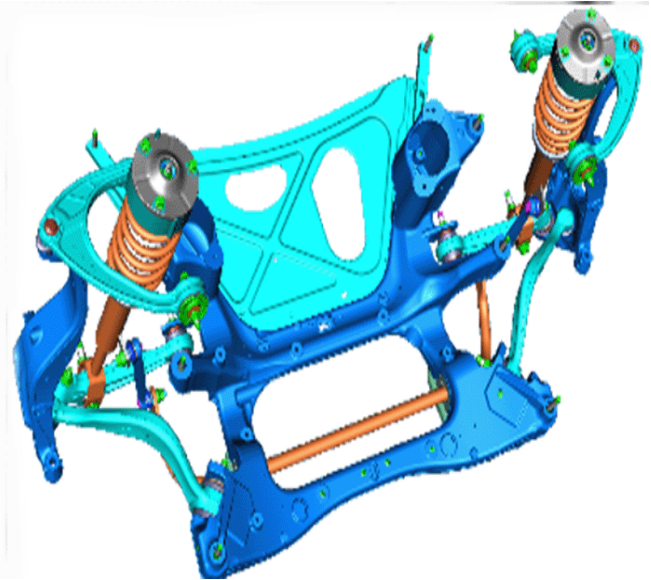

4481463

The CT6 comes equipped with a high arm multi-link short/long arm suspension. The control arms are made from forged aluminum to reduce weight. The multi-link suspension replaces the lower control arms with two lower links. This allows for improved steering feel and improved ride.

- **Dark Blue:** Cast Aluminum
- **Light Blue:** Wrought Aluminum

Rear Suspension

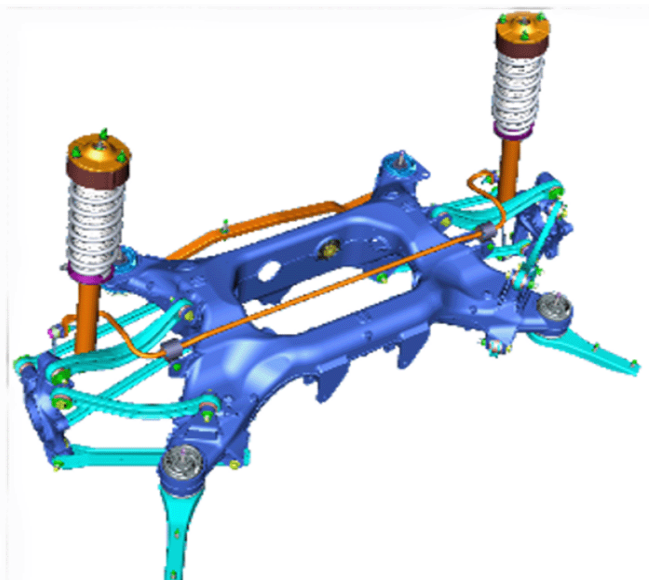

4481563

The 5-link rear suspension uses forged aluminum control links to increase strength and reduce weight. The long suspension links minimize caster and camber change. Multiple outer ball joints and cross-braces improve handling, steering precision, and agility.

- **Dark Blue:** Cast Aluminum
- **Light Blue:** Wrought Aluminum

Front and Rear Frames

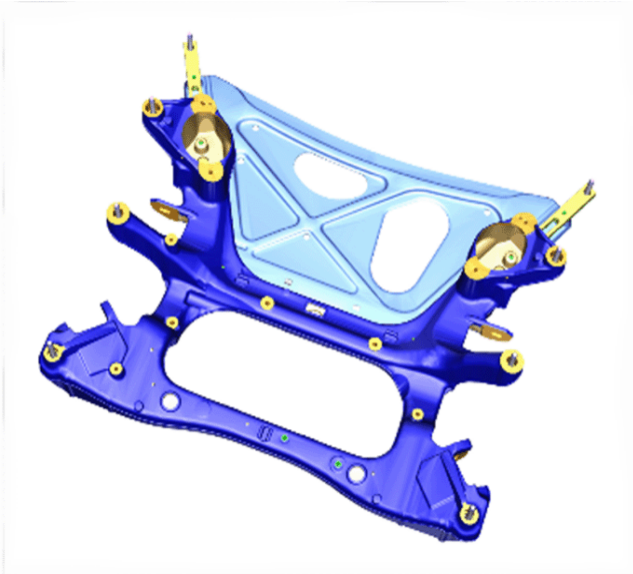

4481234

Front Frame

The individual underbody components contribute directly to the overall strength of the unibody, as well as to the overall handling performance of the vehicle. The front and rear cradles are a hollow-cast aluminum to reduce weight. The front and rear frames serve as a foundation for the front and rear suspension. The frames are also an integral part of the unibody structure. The front frame serves as a foundation for the front suspension and for the front axle on all-wheel drive (AWD) equipped vehicles.

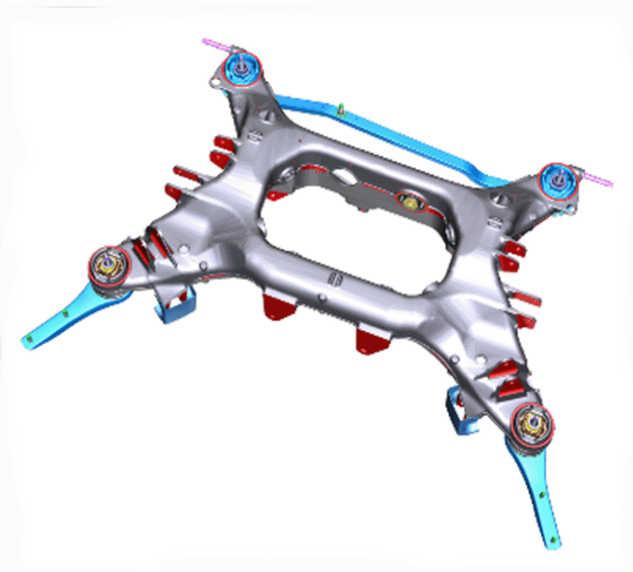

4481345

Rear Frame

The rear frame, which attaches to the body rail through rubber insulators, is the foundation for the rear suspension components and the rear axle.

Transfer Case — Rear-Wheel Drive and All-Wheel Drive

Overview

The driveline in the 2016 Cadillac CT6 uses either a rear-wheel drive (RWD) or an all-wheel drive (AWD) configuration. The RWD configuration uses a longitudinally mounted engine and transmission to transfer power through the two-piece propeller shaft to the rear drive axle. The AWD configuration adds an active transfer case after the transmission that splits the power between the one-piece front propeller shaft and the two-piece rear propeller shaft. AWD is standard on all V6 models.

Transfer Case

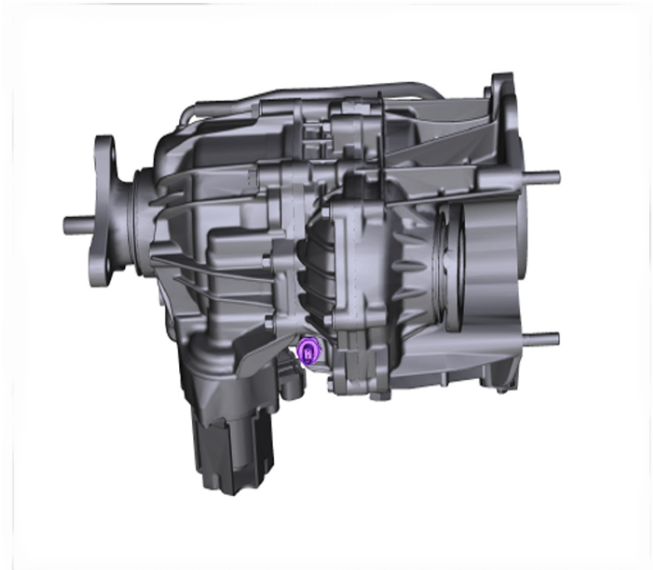

4481166

The CT6 AWD features a Magna model MP 3713G one-speed transfer case. Software calibrations tune an on-demand torque biasing friction clutch. When a driver enters a turn, clutch torque decreases based on the various GM LAN inputs, such as steering angle and vehicle speed to prevent crowhop or driveline binding from occurring at low speeds.

Transfer Case Clutch

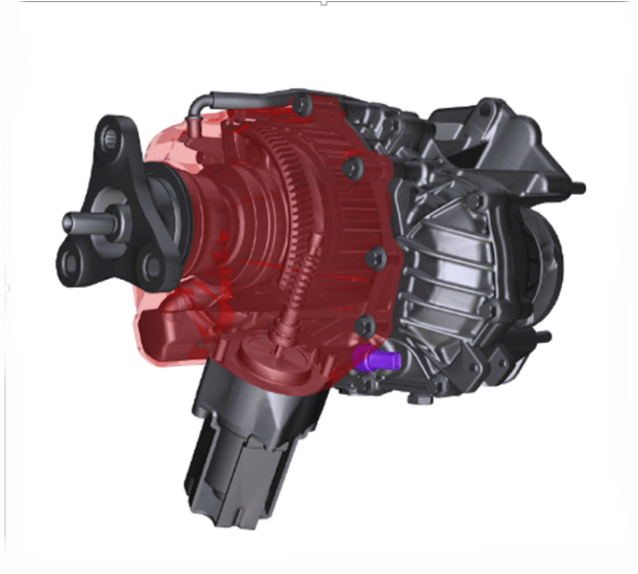

4481126

The torque split between the front and rear axle is not fixed, which differs from an open center differential transfer case. The active design can transfer 0 to 100 percent of the torque to the front axle. The torque transfer is adjusted based on multiple inputs including: wheel slip, engine speed, throttle position, transmission gear and the selected driving mode. Torque is moved to the front axle through an active wet clutch within the transfer case. The actuator motor turns a worm gear that rotates the shift shaft that actuates a scissor mechanism and applies the clutch.

**Transmissions — HydraMatic™ 8L45
Automatic 8-Speed Transmission —
RPO M5N and 8L90 Automatic 8-Speed
Transmission — RPO M5X**

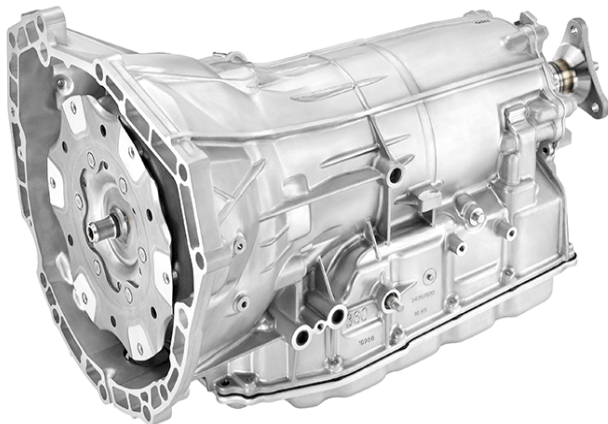

4479842

Typical view of the 8L45

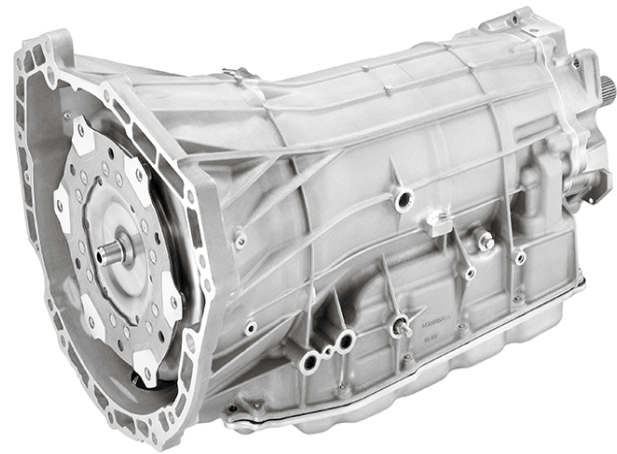

4481052

Typical view of the 8L90

HydraMatic™ 8L45 and 8L90

The all new, GM developed HydraMatic™ 8L45/8L90 eight-speed automatic transmission packaged on the CT6 enhances performance and efficiency, while delivering exceptional refinement and world-class shift responsiveness that rivals the world's best dual-clutch transmissions.

With four simple gearsets for optimal efficiency and five clutches (two brake clutches and three rotating clutches), creative packaging enables the new eight-speed automatic to fit the same space as previous six-speed automatics – and the powerflow only has two open clutches per gear for low spin losses, enhancing efficiency. Extensive use of aluminum and magnesium also make it similar in mass to six-speed configurations. The greater overall performance and efficiency enabled by the 8L45/8L90 in the CT6 is due in part to a new, wider 7.0 overall gear ratio spread, which enhances off-the-line performance with a more aggressive first gear ratio of 4.56, helping achieve quicker 0-60 mph (0-97 km/h) times.

For performance driving, the transmission offers full manual control via steering wheel paddles. A new transmission controls system and unique algorithms deliver shift performance that rivals the dual-clutch/semi-automatic transmissions found in many high performance cars, but with the smoothness and refinement that comes with a conventional automatic fitted with a torque converter.

A new, Gen III transmission controller analyzes and executes commands 160 times per second. Smaller steps between gears keep the engine within the sweet spot of the RPM band, making the most of its horsepower and torque to optimize performance and efficiency. Additionally, a torque converter design with a turbine damper complements performance with excellent refinement at low RPM.

8L45 and 8L90 Application

The 8L45 will be mated with the 2.0L Turbo and the 3.6L V6 engine and the 8L90, which is designed and tuned for higher power outputs, is matched with the 3.0L V6 twin turbocharged engine.

When inspecting the transmission fluid level, refer to this procedure: Transmission Fluid Level and Condition Check in SI

Towing the Vehicle — Recreational Vehicle Towing

Towing the Vehicle

Have the vehicle towed on a flatbed car carrier. A wheel lift tow truck could damage the vehicle.

Recreational Vehicle Towing

Recreational vehicle towing means towing the vehicle behind another vehicle such as a motor home. If the vehicle must be towed, a dolly should be used.

Vehicles with **all-wheel drive cannot be dolly towed.**

To dolly tow a **rear-wheel drive vehicle from the rear** perform the following:

1. Attach the dolly to the tow vehicle following the dolly manufacturer instructions.
2. Put the rear wheels on the dolly.
3. Shift the transmission to **P** (Park).

4. Firmly set the parking brake.
5. Use an adequate clamping device designed for towing to ensure that the front wheels are locked into the straight-ahead position.
6. Secure the vehicle to the dolly following the manufacturer instructions.
7. Release the parking brake only **after** the vehicle being towed is firmly attached to the towing vehicle.
8. Turn OFF the ignition.

In the Event of a Collision

In the event of a collision, CT6 vehicles requiring structural repairs should be sent to a Cadillac Aluminum Repair Network (CARN) facility. These approved facilities have the training, equipment and tools necessary to properly perform structural repairs, restoring the vehicle as close to its pre-collision condition as possible. In Canada, Cadillac dealers that determine a CT6 requires structural repair or quarter panel replacement should refer the vehicle to one of the Cadillac certified aluminum repair facilities in Canada.

Special Tools

The following new tools were released for the 2016 CT6:

Special Tools — Tool Number and Description

Tool Number	Description
CH-50732-A	Strut Rod Nut Wrench
DT-50806-10	Bushing Replacer Adapter
DT-51263	Pinion Flange Installer
DT-51750	Pinion Seal Installer (RDM)
J-28540-A	RDM Output Seal Installer
DT-51976	FDU Output Seal Installer
DT-51977	FDU Pinion Seal Installer
J-44467	FDU Intermediate Shaft Remover

Training Courses

The majority of the systems found on this vehicle are taught in GM's core curriculum from a conceptual theory and operation perspective. The North American technical training core curriculum structure is system based.

To access **all** of the available training courses in the United States, visit the following website:

www.centerlearning.com

In Canada, Go to **GM GlobalConnect and select Centre of Learning**

Training Course Name or System — Course Number and Description

Course Name or System	Course Number and Description
<p>New Model Feature 2016 Cadillac CT6 New Model Feature</p>	#10316.65W — 2016 Cadillac CT6 New Model Feature (United States and Canada)
<p>Engine Gasoline, 4 Cylinder L4, 2.0L, SIDI, DOHC, VVT, DCVCP, TURBOCHARGED — RPO LTG Gasoline, 6 CYL, V6, 3.0L, DI, DOHC, VVT, TWIN TURBOCHARGED — RPO LGW Gasoline, 6 Cylinder, V6, 3.6L, DI, DOHC, VVT — RPO LGX</p>	<p>#16440.17D-V — Engines: New and Updates for RPOs LCV, LTG, LL0 (United States Only) #16043.16H — Gen 2 Overhaul/Repair Certification (Canada Only) #16440.20D — Engines: New and Updates for RPOs LF4, LGX, LGW, L3A, LV7, LE2 and LWN (United States Only)</p>
<p>Transmission HydraMatic™ 8-Speed Automatic Transmissions — RPO M5N and M5X</p>	<p>#17440.16D (VCT) — Transmissions: New and Updates for Aisin AF50-8, 8L45/8L90 Automatic Transmissions (United States Only) #17038.05D1/D2 — 8L90 Transmission Operation and Diagnosis (Canada Only) #17038.06V — 8L90 Unit Repair (Canada Only)</p>
<p>Safety Systems Forward Collision Alert / Lane Departure Warning and Rear Vision Camera</p>	#22048.42W1-W3 GM Safety Systems 1-3 (United States and Canada)

Version Information

Version	1
Modified	—

Trademark Footnotes

Apple® is a Registered Trademark of Apple Inc.

Bose® is a Registered Trademark of the Bose Corporation

Bose® Panaray® is a Registered Trademark of the Bose Corporation

Bose® VideoWave® and Articulated Array® are Registered Trademarks of the Bose Corporation

The Bluetooth® Word Mark and Logos are Registered Trademarks Owned by Bluetooth SIG, Inc.

dexos® is a Registered Trademark of General Motors LLC

dexos1® Icons are Registered Logos of General Motors LLC

Google® is a Registered Trademark of Google Inc.

HydraMatic™ is a Trademark of General Motors LLC

iPhone® is a Registered Trademark of Apple Inc.

OnStar® is a Registered Trademark of OnStar LLC

Siri® Eyes Free Voice Recognition Software is a Registered Trademark of Apple Inc.

Siri® is a Registered Trademark of Apple Inc.

StabiliTrak® is a Registered Trademark of General Motors LLC

