

May 15, 2015

01746 Version 1

Rubbing or Groaning from the Driver's Front Airbag Area

AFFECTED VEHICLES

Year	Model	Trim	VIN Range
2013–14	Accord	ALL	ALL
2015	Accord	L4 Coupe	1HGCT1B8...000001 thru 1HGCT1B8...005372
2015	Accord	L4 Sedan	1HGCR2F5...000001 thru 1HGCR2F5...082162
2015	Accord Hybrid	ALL	1HGCR6F5...000001 thru 1HGCR6F5...004895
2015	Accord	V6 Coupe	1HGCT2B8...000001 thru 1HGCT2B8...003790
2015	Accord	V6 Sedan	1HGCR3F8...000001 thru 1HGCR3F8...014358
2013–14	Crosstour	ALL	ALL
2015	Crosstour	L4	5J6TF3...FL000001 thru 5J6TF3...FL001082
2015	Crosstour	V6	5J6TF2...FL000001 thru 5J6TF2...FL002125

SYMPTOM

A rubbing or groaning is heard from the driver's front airbag module while turning the steering wheel.

POSSIBLE CAUSES

Noise is generated from moving parts/friction within the damper assemblies in the horn plate assembly.

CORRECTIVE ACTION

Replace the horn plate assembly.

PART INFORMATION

Part Name	Part Number	Quantity
Horn Plate Assembly	77811-T2A-A70	1
Torx bolt	90134-S6A-A80	2

WARRANTY CLAIM INFORMATION

The normal warranty applies.

Operation Number	Description	Flat Rate Time	Template ID	Failed Part Number
7111A5	Replace Horn Plate Assembly	0.4 hr	15-023A	78501-T2A-U51ZA

Defect Code: 07403

Symptom Code: 04201

Skill Level: Repair Technician

CUSTOMER INFORMATION: The information in this bulletin is intended for use only by skilled technicians who have the proper tools, equipment, and training to correctly and safely maintain your vehicle. These procedures should not be attempted by "do-it-yourselfers," and you should not assume this bulletin applies to your vehicle, or that your vehicle has the condition described. To determine whether this information applies, contact an authorized Acura automobile dealer.

REPAIR PROCEDURE

1. Make sure the ignition is turned to OFF.
2. Disconnect and isolate the negative cable with the battery sensor from the battery.

NOTE:

- Always disconnect the negative cable first.
- To protect the battery sensor connector from damage, do not hold it when removing the negative terminal.
- Do not disconnect the battery sensor from the negative terminal.

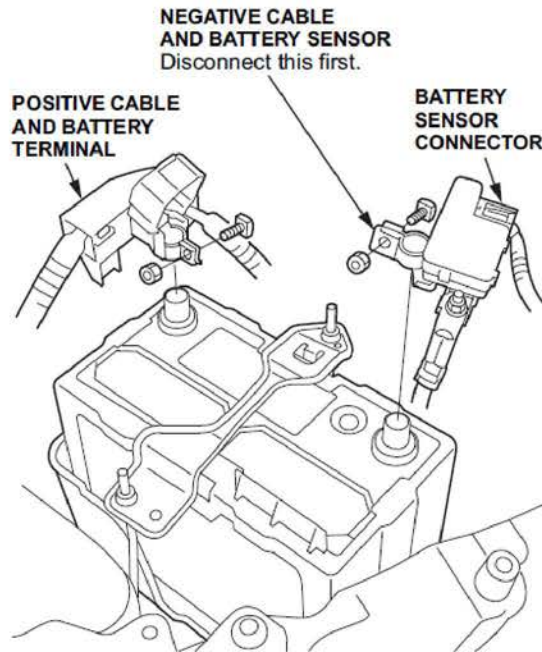

3. Disconnect the positive battery cable and the battery terminal from the battery.
4. Wait at least 3 minutes before starting work to allow the airbag system to de-energize.
5. Remove the Torx bolts using a Torx T-30.

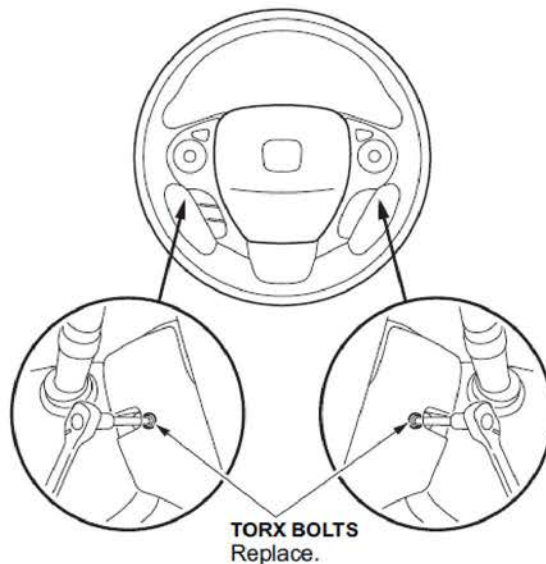

6. Pull up on both locking tabs to disconnect the driver's airbag inflator connectors on the cable reel harness.

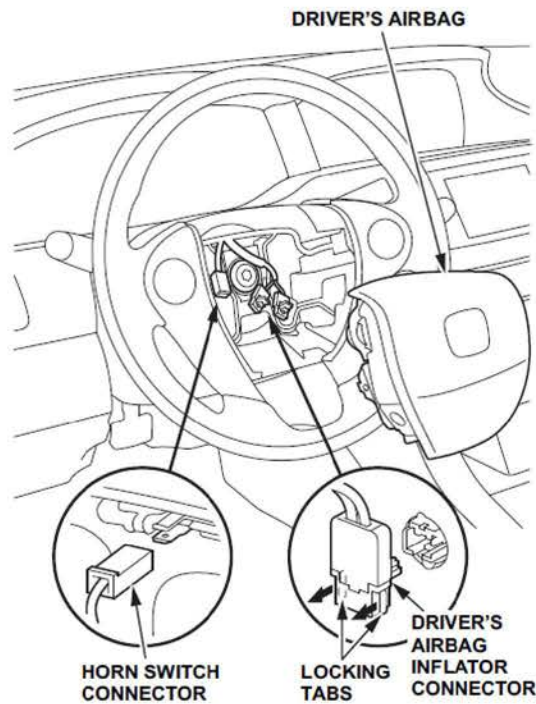

7. Disconnect the horn switch connector.
8. Remove the driver's airbag.
9. Remove the three horn plate assembly bolts and washers and discard. Remove the three springs and discard.

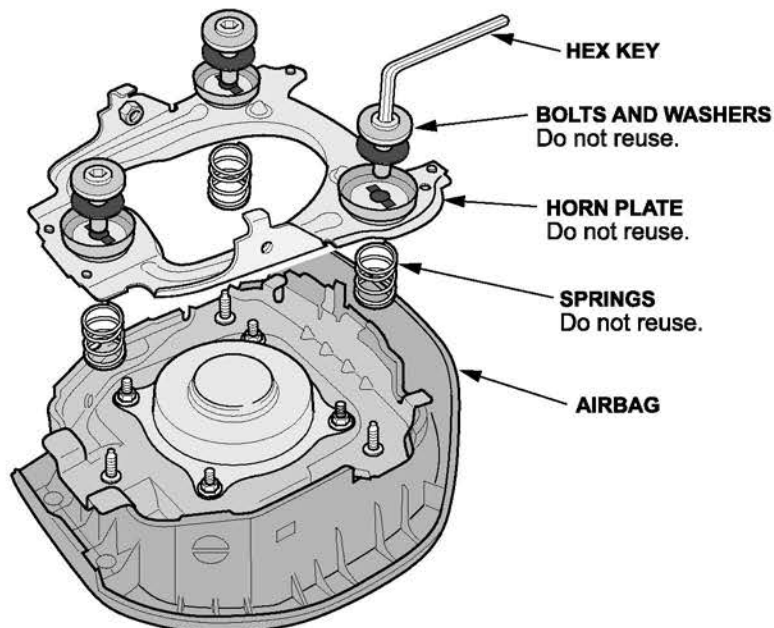

10. Install the new Horn Plate Assembly with the new bolts, washers, and springs. Torque the bolts to $(3.5 \pm .05 \text{ N}\cdot\text{m})$, $(2.5 \pm .03 \text{ lb}\cdot\text{ft})$.

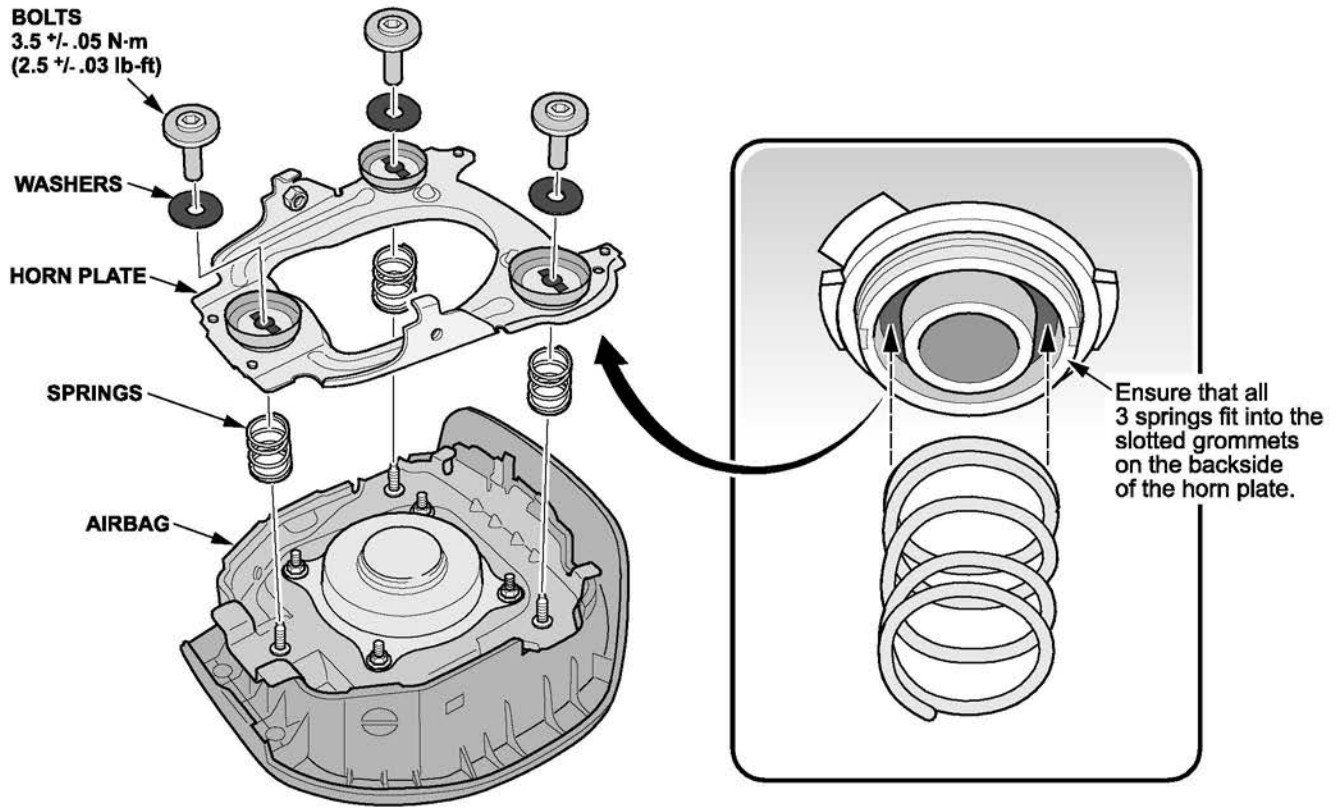

11. Connect the driver's airbag inflator connector to the cable reel subharness to the airbag by aligning the guide tab to the groove on the connectors.

NOTE: Do not pinch the driver's airbag inflator harness.

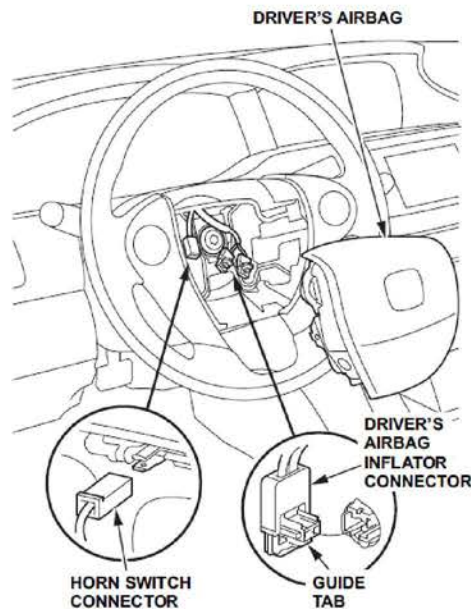

12. Connect the horn switch connector.
13. Place the driver's airbag in the steering wheel.
14. Torque the new Torx bolts to **9.4 N·m (6.9 lb-ft)**.

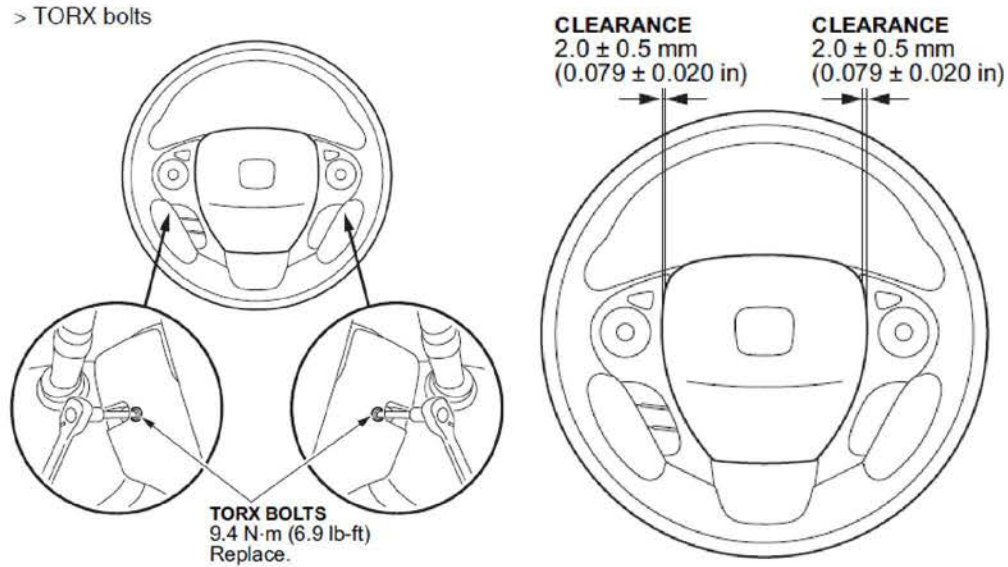

15. Reconnect the positive cable to the battery terminal.
NOTE: Always connect the positive side first.
16. Reconnect the negative cable to the battery terminal.
NOTE: To protect the battery sensor connector from damage, do not hold it when installing the negative terminal.
17. Clear any DTCs with the HDS.
18. Turn the ignition to ON, check that the SRS indicator should come on for about 6 seconds and then goes off.

END.