

July 16, 2015

02111 Version 2

## Safety Recall: A/C Compressor Clutch (Center) Bolt

Supersedes 15-037, titled *Safety Recall: A/C Compressor Clutch Bolt*, dated June 6, 2015, to include warranty and parts information and repair procedures

### AFFECTED VEHICLES

Year	Model	Trim	VIN range
2014–15	MDX	ALL with 2WD	Check the iN VIN status for eligibility
2014–15	MDX	ALL with SH-AWD	Check the iN VIN status for eligibility

### SYMPTOM

As a result of a manufacturing error, the A/C compressor clutch (center) bolt may come loose and fall out or break. If the bolt comes off, the A/C clutch pressure plate (drive plate) may also fall off the vehicle while it is being driven.

### CLIENT NOTIFICATION

Owners of affected vehicles will be sent a notification of this campaign.

Do an iN VIN status inquiry to make sure the vehicle is shown as eligible.

Some vehicles affected by this campaign may be in your new or used vehicle inventory. These vehicles must be repaired before they are sold.

Should your dealership sell an unrepaired vehicle or fail to do the inspection or flush on a vehicle according to this bulletin, and that vehicle subsequently causes injury or damage because of the recalled item, the dealership will be solely responsible to the damaged party, and will be required to defend and indemnify American Honda for any resulting claims. To see if a vehicle in inventory is affected by this recall, do a iN VIN status inquiry before selling it.

### CORRECTIVE ACTION

Replace the A/C compressor clutch bolt. If the bolt is missing or broken, you may need to replace the clutch set. If the bolt is broken and can't be removed, you need to replace the A/C compressor and may need to replace the compressor clutch and/or the compressor clutch coil.

**CLIENT INFORMATION:** The information in this bulletin is intended for use only by skilled technicians who have the proper tools, equipment, and training to correctly and safely maintain your vehicle. These procedures should not be attempted by "do-it-yourselfers," and you should not assume this bulletin applies to your vehicle, or that your vehicle has the condition described. To determine whether this information applies, contact an authorized Acura automobile dealer.

## PARTS INFORMATION

### NOTE:

- **DPSM authorization is required to order the clutch set and/or compressor and to submit labor authorization number 6141D0A.** Authorization is not required for A/C compressor clutch bolt ordering or replacement.
- **WPI will call in A/C clutches and A/C compressors for inspection.**
- **The A/C compressor clutch bolt is a one time use bolt.** If after installing the bolt, you need to remove it for any reason, including setting the compressor clutch clearance, you need to replace it with a new one.
- The replacement rate for the clutch set, A/C compressor, coil set, and O-rings is very low. Order replacement parts only after confirming that a replacement part is needed.

### Parts needed when bolt is present or broken bolt can be removed

Part Name	Part Number	Quantity
Flange Bolt (A/C Compressor Clutch Bolt)	38823-5J6-A11	1

### Parts needed when A/C clutch pressure plate missing

Part Name	Part Number	Quantity
Clutch Set	38900-5J6-A02	1
Flange Bolt (A/C Compressor Clutch Bolt)	38823-5J6-A11	1
O-Ring (5/8 in.)	80871-SN7-003	1
O-Ring (1/2 in.)	80872-SN7-003	1

### Parts needed when broken bolt can't be removed

Part Name	Part Number	Quantity
A/C Compressor	38810-5J6-A03	1
Clutch Set	38900-5J6-A02	1
O-Ring (5/8 in.)	80871-SN7-003	1
O-Ring (1/2 in.)	80872-SN7-003	1

## TOOL INFORMATION

Tool Name	Tool Number	Quantity
A/C Clutch Holder	OTCJ33027A	1

Each dealer was recently shipped an A/C clutch holder. Additional A/C clutch holders are available for purchase through the Acura Tool and Equipment program.

## WARRANTY CLAIM INFORMATION

**NOTE: DPSM authorization is required to order the clutch set and/or compressor and to submit labor authorization number 6141D0A. Authorization is not required for bolt ordering or replacement.**

Operation Number	Description	Flat Rate Time	Failed Part Number
6141D0	Replace the A/C compressor clutch bolt on the vehicle.	0.6 hr	38810-5J6-A02
A	Remove the A/C compressor (includes A/C evacuation/recharge) from the vehicle and do one of the following: - Replace the A/C compressor clutch bolt - Replace the A/C clutch set - Replace the A/C compressor	1.4 hrs	38810-5J6-A02

Defect Code: 5ZU00

Symptom Code: JQ700

Skill Level: Repair Technician

## INSPECTION PROCEDURE

1. Raise the vehicle on a lift.
2. Remove the right front wheel.
3. Remove the screws, bolts, and clips as shown from the front bumper and the front bumper air spoiler.

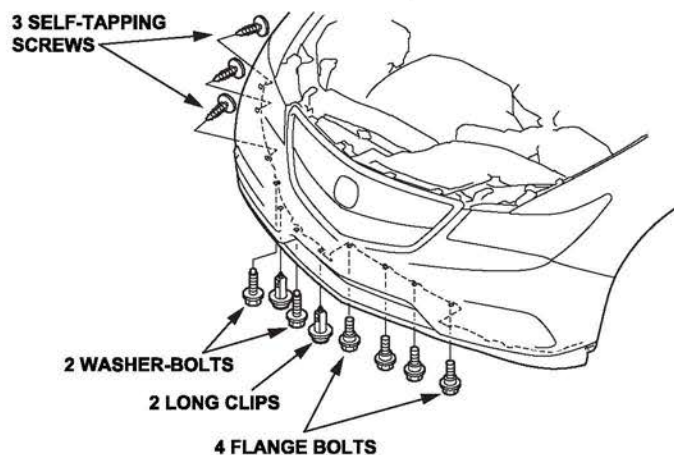

4. Remove the bolt, the clip, and the screw as shown from the splash shield and move it out of the way.

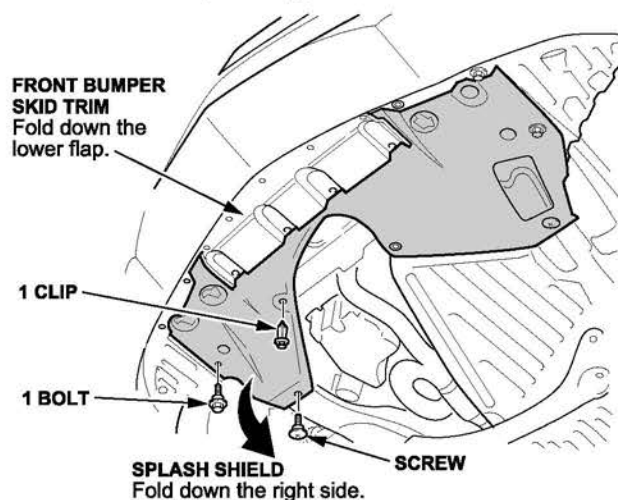

5. Remove the clips and pull back the inner fender and splash shield to access the A/C compressor.

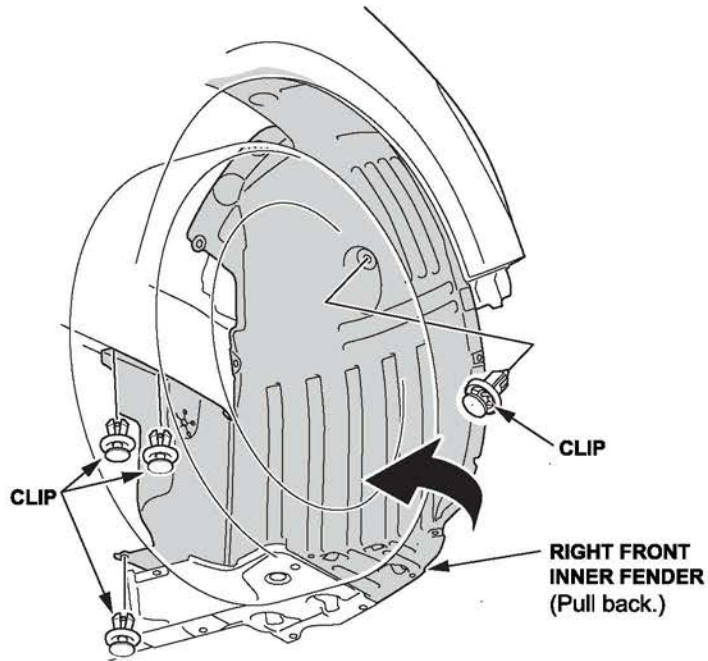

6. Remove the G202 ground bolt.

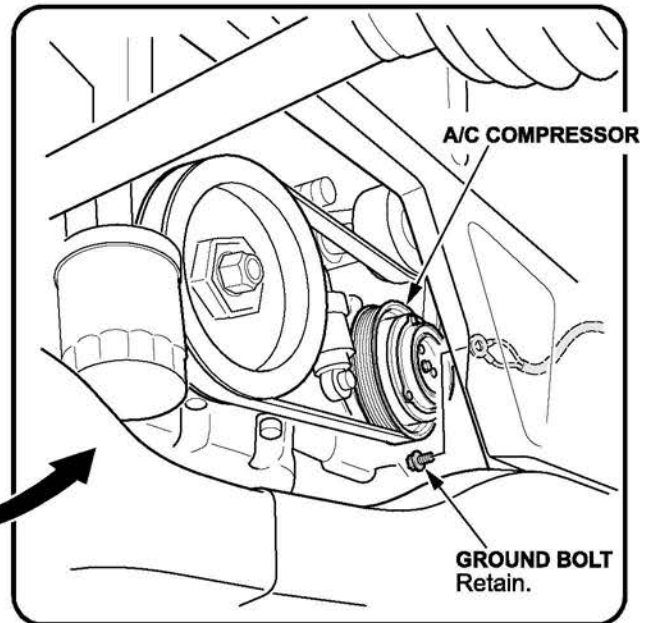

7. Check to see if the A/C compressor pressure plate is present.
  - If the pressure plate is present, go to step 8.
  - If the pressure plate is missing, go to REPAIR PROCEDURE C.

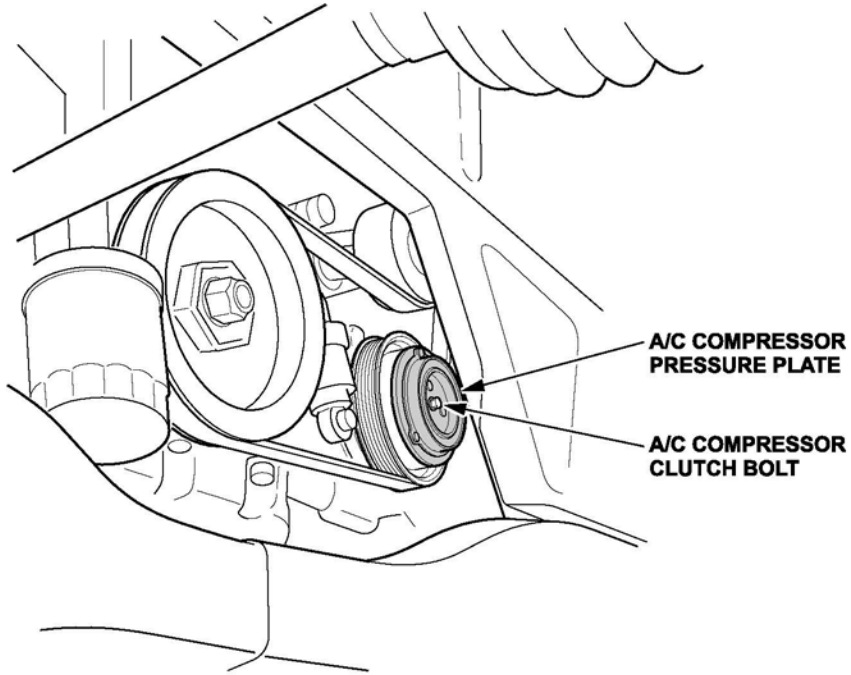

8. Inspect the A/C compressor clutch bolt.
  - If the bolt is OK, go to REPAIR PROCEDURE A.
  - If the bolt is missing, go to REPAIR PROCEDURE A.
  - If the bolt is broken, go to step 9.
9. Try to remove the broken bolt.
  - If the bolt can be removed, go to REPAIR PROCEDURE A.
  - If the bolt can't be removed, go to REPAIR PROCEDURE B.

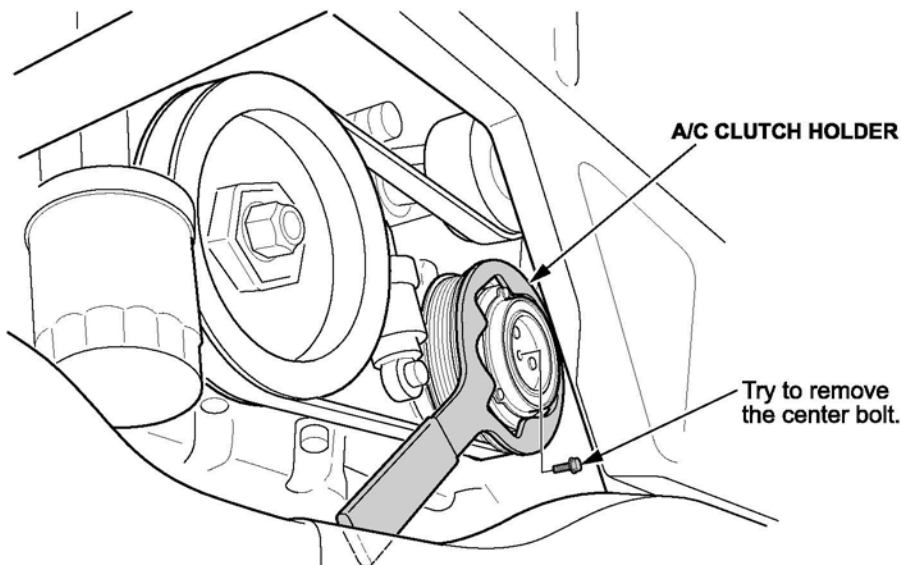

## REPAIR PROCEDURE A

1. If not already done, remove the A/C compressor clutch bolt using T/N OTCJ33027A to hold the clutch plate.

NOTE: If the bolt breaks during removal, try to remove the broken bolt.

- If you can remove the bolt, go to step 2.
- If the broken bolt can't be removed, go to REPAIR PROCEDURE B.

2. Use compressed air to blow any debris out of the shaft threads.

3. If the bolt was loose or missing, check the pressure plate and pulley friction surfaces for damage or wear.

NOTE: If the bolt wasn't loose or missing, go to step 4.

- **If the friction surfaces are damaged or worn**, replace the A/C compressor clutch set and adjust the clearance to 0.35–0.65 mm (0.014–0.026 in.), then go to step 4.
- **If the friction surfaces are not damaged or worn**, go to step 4.

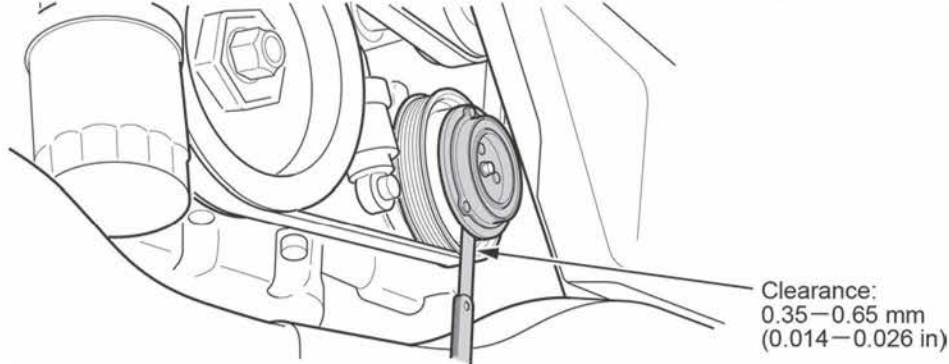

4. Install the new A/C compressor clutch bolt using T/N OTCJ33027A and torque the bolt to **12 N·m (9 lb-ft)**.

NOTE:

- Make sure you torque the bolt to 12 N·m (9 lb-ft); do not use a higher value or you may break the bolt.
- **The A/C compressor clutch bolt is a one time use bolt.** If after installing the bolt, you need to remove it for any reason, including setting the compressor clutch clearance, you need to replace it with a new one.

For clearance, the distance from the tip of the socket to the back of the torque wrench should not exceed 40mm.

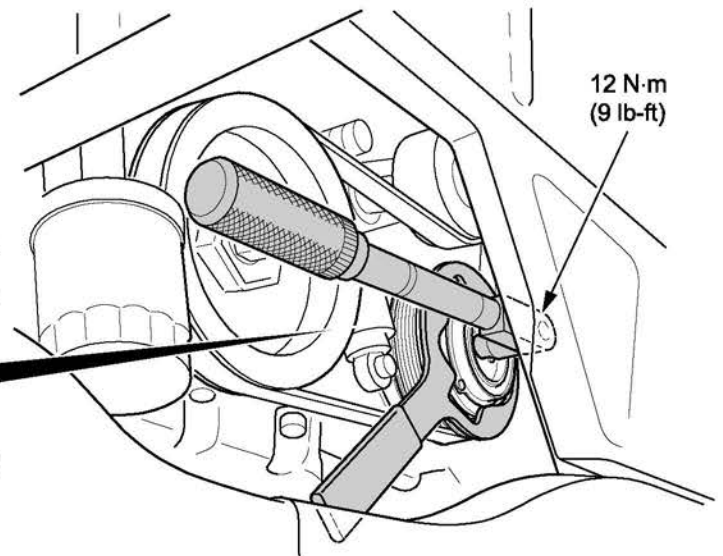

5. Reinstall the G202 ground bolt.
6. Reinstall the inner fender and splash shield in the reverse order of removal.
7. Reinstall the wheel and torque the lug nuts to **108 N·m (80 lb-ft)**.
8. Make sure the A/C works properly.

## REPAIR PROCEDURE B

1. Recover the refrigerant, then remove the A/C compressor.
2. Try to remove the broken bolt from the A/C compressor.
  - If you can remove the bolt, use compressed air to blow any debris out of the shaft threads, then go to step 3.
  - If you can't remove the broken bolt, replace the A/C compressor. Set the A/C compressor clutch clearance to 0.35–0.65 mm (0.014–0.026 in.). Make sure you use a new A/C compressor clutch bolt when assembling the A/C compressor.

### NOTE:

- **DPSM authorization is required to order the clutch set and/or compressor.**
  - Transfer the A/C compressor clutch and coil even if the broken bolt cannot be removed. In rare cases, the A/C compressor clutch and coil cannot be transferred to the new unit. In these cases, replace the A/C compressor clutch and coil.
  - **The A/C compressor clutch bolt is a one time use bolt.** If after installing the bolt, you need to remove it for any reason, including setting the compressor clutch clearance, you need to replace it with a new one.
3. Install the new A/C compressor clutch bolt, then torque the bolt to **12 N·m (9 lb-ft)** using T/N OTCJ33027A.

NOTE: Make sure you torque the bolt to **12 N·m (9 lb-ft)**; do not use a higher value or you may break the bolt.

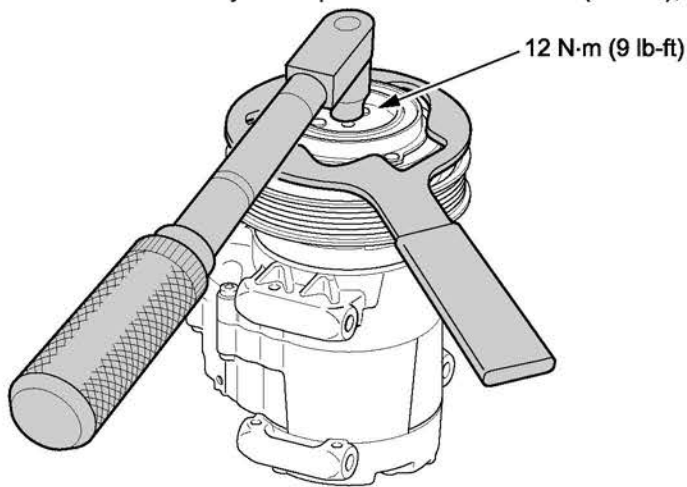

4. Reinstall the A/C compressor.
5. Reinstall the G202 ground bolt.
6. Reinstall the inner fender and splash shield in the reverse order of removal.
7. Reinstall the wheel and torque the lug nuts to **108 N·m (80 lb-ft)**.
8. Evacuate and recharge the A/C system.
9. Make sure the A/C works properly.

## REPAIR PROCEDURE C

1. Recover the refrigerant, then remove the A/C compressor.
2. Inspect the compressor shaft for a broken A/C compressor clutch bolt.
  - If part of the bolt is still in the shaft, go to step 3.
  - If the bolt is completely gone, go to step 4.
3. Try to remove the broken bolt.
  - If you can remove the broken bolt, go to step 4.
  - If you can't remove the broken bolt, replace the A/C compressor and compressor clutch. Try to transfer the original compressor clutch coil to the new A/C compressor, then go to step 6.

### NOTE:

- **DPSM authorization is required to order the clutch set and/or compressor.**
  - Transfer the A/C compressor coil even if the broken bolt cannot be removed. In rare cases, you may not be able to transfer the coil. In these cases, replace it with a new one.
  - **The A/C compressor clutch bolt is a one time use bolt.** If after installing the bolt, you need to remove it for any reason, including setting the compressor clutch clearance, you need to replace it with a new one.
4. Use compressed air to blow any debris out of the shaft threads.
  5. Replace the clutch set.
  6. Adjust the A/C compressor clutch clearance to 0.35–0.65 mm (0.014–0.026 in.) using the shims supplied with the clutch set, then torque the A/C compressor clutch bolt to **12 N·m (9 lb-ft)** using T/N OTCJ33027A.

NOTE: Make sure you torque the bolt to **12 N·m (9 lb-ft)**; do not use a higher value or you may break the bolt.

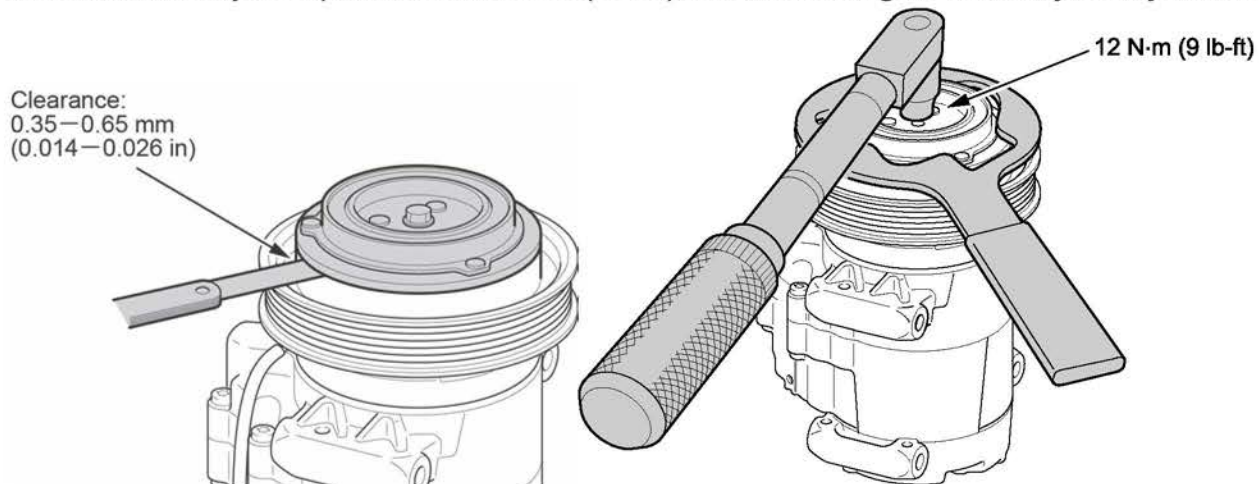

7. Reinstall the A/C compressor.
8. Reinstall the G202 ground bolt.
9. Reinstall the inner fender and splash shield in the reverse order of removal.
10. Reinstall the wheel and torque the lug nuts to **108 N·m (80 lb-ft)**.
11. Evacuate and recharge the A/C system.
12. Make sure the A/C works properly.

END