

August 25, 2015

51398-02259 Version 2

Function Buttons (PHONE, MENU, BACK, SETTINGS, Etc.) Stick

Supersedes 14-022, dated May 21, 2014, to revise the information highlighted in yellow.

AFFECTED VEHICLES

Year	Model	Trim	VIN Range
2014	Odyssey	ALL	ALL
2015	Odyssey	EX, EX-L, Touring	5FNRL5...FB000001 thru 5FNRL5...FB115934

REVISION SUMMARY

All Sections were revised; American Honda recommends that you review the entire bulletin.

SYMPTOM

One or more of the function buttons around the center switch panel dial (PHONE, MENU, BACK, SETTINGS, Etc.) are sticking.

POSSIBLE CAUSE

The center switch panel is deformed or is not centered in the audio unit panel.

CORRECTIVE ACTION

Replace or adjust the center switch panel in the audio unit panel as needed.

NOTE: Only replace the center switch panel if the PHONE button is sticking. Replacing the panel if any other buttons are sticking may not resolve the issue.

PARTS INFORMATION

Vehicle Trim	Part Name	Part Number	Quantity
EX and EX-L	Switch Assy, Multi Jog (Audio)	39050-TK8-A31	1
EX-L with RES	Switch Assy, Multi Jog (RES)	39050-TK8-A21	1
EX-L with NAVI	Switch Assy, Multi Jog (NAVI)	39050-TK8-A11	1
Touring	Switch Assy, Multi Jog (NAVI)(RES)	39050-TK8-A01	1

CUSTOMER INFORMATION: The information in this bulletin is intended for use only by skilled technicians who have the proper tools, equipment, and training to correctly and safely maintain your vehicle. These procedures should not be attempted by "do-it-yourselfers," and you should not assume this bulletin applies to your vehicle, or that your vehicle has the condition described. To determine whether this information applies, contact an authorized Honda automobile dealer.

WARRANTY CLAIM INFORMATION

The normal warranty applies.

Repair Procedure A

Operation Number	Description	Flat Rate Time	Template ID	Failed Part Number
0100A4	Reposition the center switch panel in the audio unit panel	0.8 hr	14-022A	39050-TK8-A31

Repair Procedure B

Operation Number	Description	Flat Rate Time	Template ID	Model	Replacement Part	Failed Part Number
0101K1	Replace the center switch panel in the audio unit.	0.8 hr	14-022B	EX and EX-L	39050-TK8-A31	39050-TK8-A31
			14-022C	EX-L with RES	39050-TK8-A21	
			14-022D	EX-L with NAVI	39050-TK8-A11	
			14-022E	Touring	39050-TK8-A01	

Defect Code: 08001

Symptom Code: 03217

Skill Level: Repair Technician

DIAGNOSIS PROCEDURE

Press each function button to see if it sticks.

- If any button(s) stick except the PHONE button, go to REPAIR PROCEDURE A.
- If the PHONE button sticks, go to REPAIR PROCEDURE B.

REPAIR PROCEDURE (Center Switch Panel Removal)

NOTE:

- When working on electronic components, make sure the work area is clean and dust free.
- Make sure your hands are clean and free of oils and grease.
- Take care not to scratch the dashboard and related parts.
- Eject the disc before removing the audio unit or audio-navigation unit to prevent damaging the CD players load mechanism.
- Make sure you have the five digit anti-theft code.

1. Remove the center middle panel.

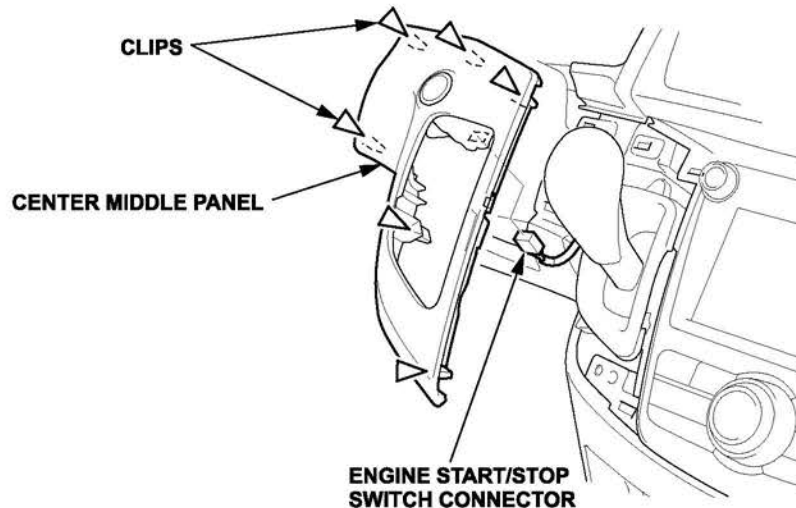

2. Pull out the front passenger's dashboard side panel to release the clips.

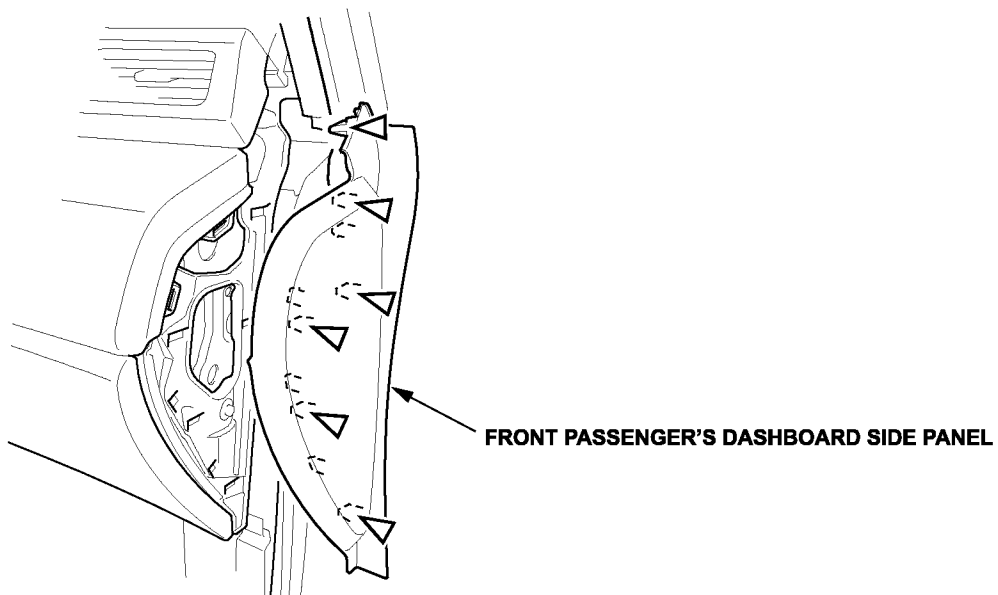

3. Remove the front passenger's middle panel.

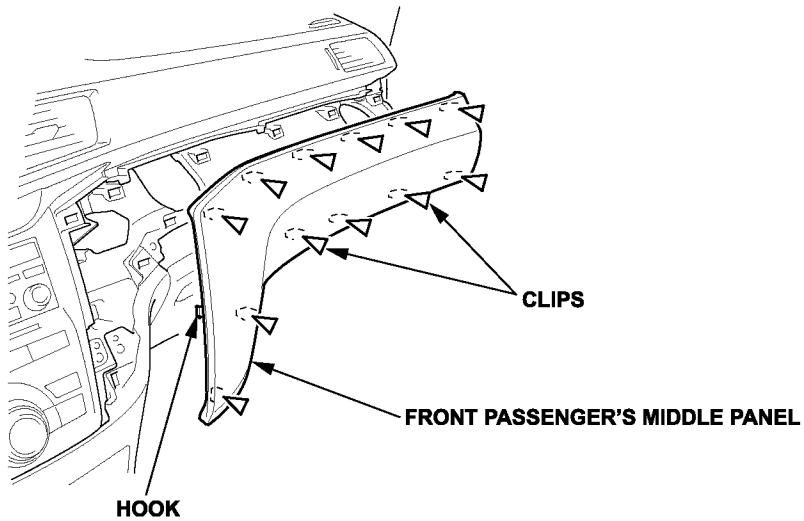

- From the front passenger's side, pull out the dashboard center panel to release the clips. From the center area, pull out the center panel to release the clips. Then, disconnect the hazard warning switch connector and climate control unit connectors and remove the panel.

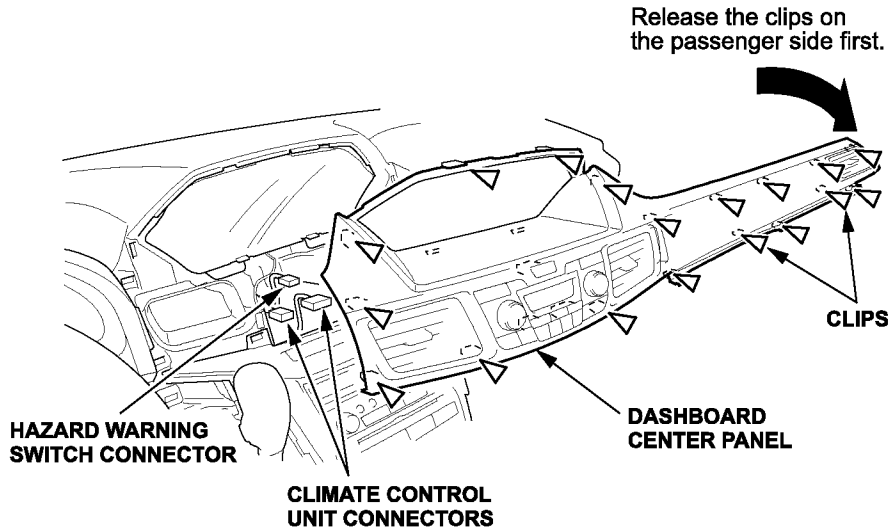

- Remove the driver's and front passenger's heater panels.

DRIVER'S SIDE

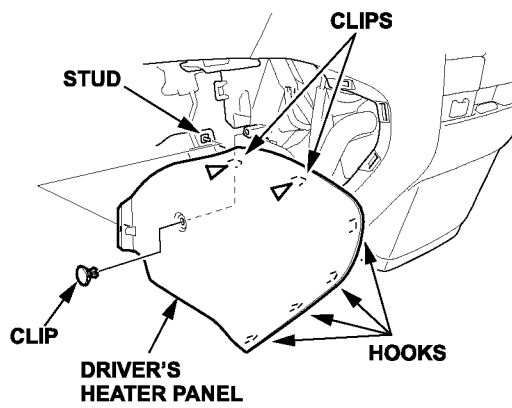

FRONT PASSENGER'S SIDE

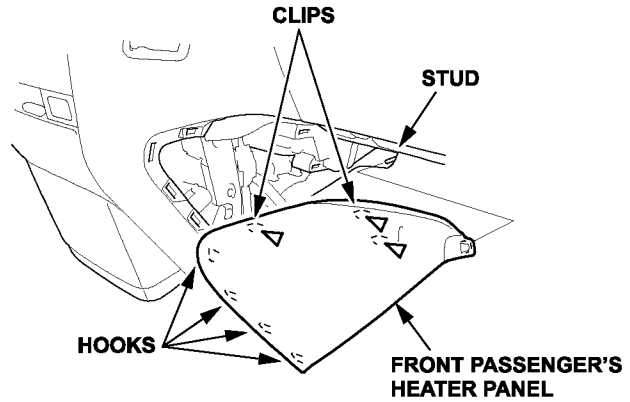

- Remove the center lower console screws.

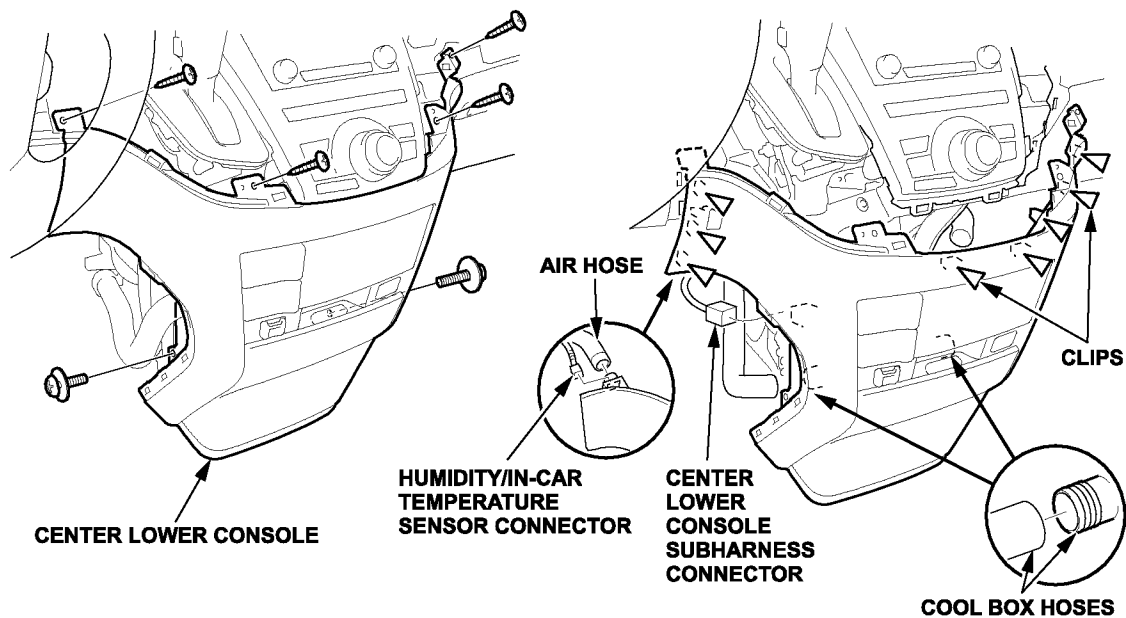

7. Pull out the center lower console as needed.
8. Remove the bolts, then pull out the audio or audio-navigation unit.

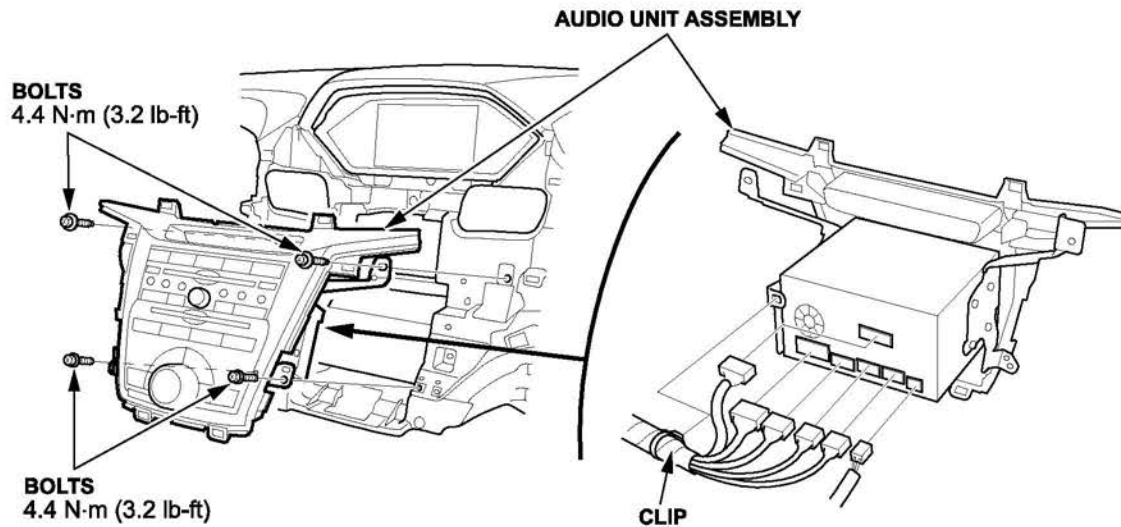

REPAIR PROCEDURE A

1. Loosen the center switch panel screws, center the switch and retighten the screws. Make sure the switch is centered in the audio or audio-navigation unit panel opening and the buttons are no longer sticking.

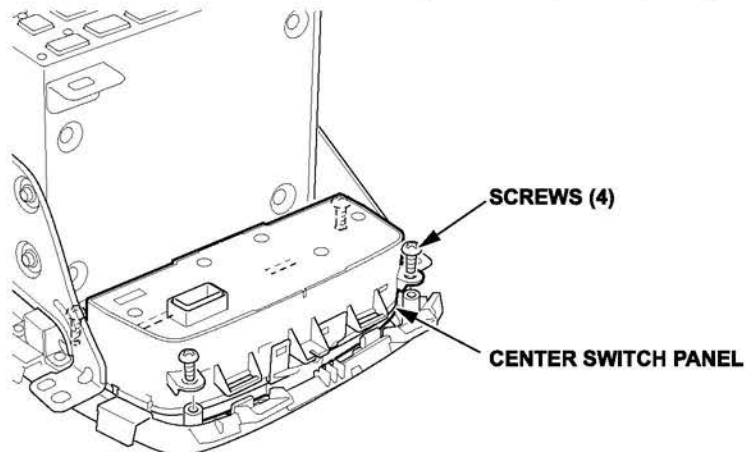

2. If the buttons are no longer sticking, reinstall all removed items in the reverse order of removal.
3. If the vehicle is equipped with navigation, do the system initialization.

NOTE:

- While the anti-theft system screen is displayed, press and hold the VOL knob for at least 2 seconds. The audio-navigation unit automatically exits the anti-theft mode, or you can enter the five digit anti-theft code.
- GPS initialization may not be needed depending of the length of time the system was without power.
- Map matching aligns the GPS to a location on the map.

REPAIR PROCEDURE B

1. Remove the four center switch panel screws and remove the center switch panel.

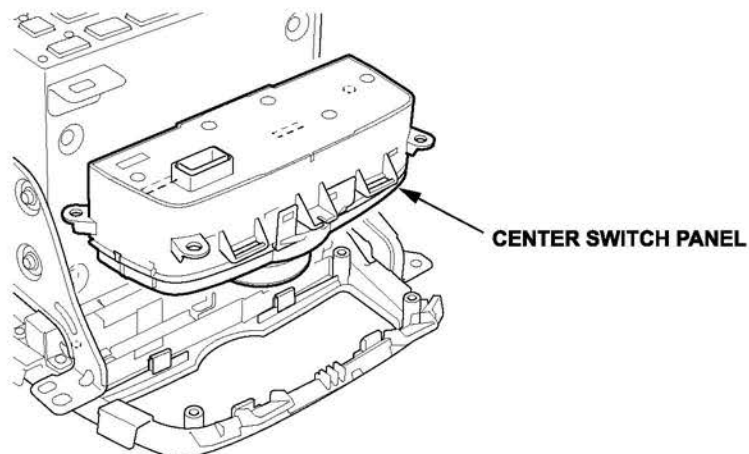

2. Install a new center switch panel.
3. Reinstall all removed items in the reverse order of removal.
4. If the vehicle is equipped with navigation, do the system initialization.

NOTE:

- While the anti-theft system screen is displayed, press and hold the VOL knob for at least 2 seconds, the audio-navigation unit will automatically exit the anti-theft mode. Alternatively, you can also enter the five digit anti-theft code.
- GPS initialization may not be needed depending of the length of the time the system was without power.
- Map matching aligns the GPS to a location on the map.

END.