

**TECHNICAL BULLETIN**  
**LTB00827NAS1**  
**29 SEP 2015**



© Jaguar Land Rover North America, LLC

NOTE: The information in Technical Bulletins is intended for use by trained, professional Technicians with the knowledge, tools, and equipment required to do the job properly and safely. It informs these Technicians of conditions that may occur on some vehicles, or provides information that could assist in proper vehicle service. The procedures should not be performed by 'do-it-yourselfers'. If you are not a Retailer, do not assume that a condition described affects your vehicle. Contact an authorized Land Rover service facility to determine whether this bulletin applies to a specific vehicle.

**SECTION: 501-00**

**'Ticking' Noise from B-Pillar Area**

**AFFECTED VEHICLE RANGE:**

**Discovery Sport (LC)**  
**Model Year:** 2015  
**VIN:** 500429-550001  
**Manufacturing Plant:** Halewood

**MARKETS:**

NAS

**CONDITION SUMMARY:**

**Situation:** A 'ticking' noise may be evident from the B-pillar area.



**NOTE:** an allowance equivalent approximately US\$58.32 has been allocated for locally sourcing of paint and materials and may be claimed using 'ZZZ001'.

**Cause:** This may be caused by the B-pillar panel clearance being incorrect.

**Action:** Should a customer express this concern, follow the Service Instruction below.

**PARTS:**

LR079642	Windshield - Standard	Quantity: 1
LR079645	Windshield - Standard and heated	Quantity: 1
LR079647	Windshield - Climate control	Quantity: 1
LR066989	Panoramic roof clips	Quantity: 7
LR078366	Rear headliner clips	Quantity: 1
LR006101	Overhead console clips	Quantity: 2

**WARRANTY:**



**NOTE:** an allowance equivalent approximately US\$58.32 has been allocated for locally sourcing of paint and materials and may be claimed using 'ZZZ001'.



**NOTE:** Repair procedures are under constant review, and therefore times are subject to change; those quoted here must be taken as guidance only. Always refer to TOPIx to obtain the latest repair time.



**NOTE:** DDW requires the use of causal part numbers. Labor only claims must show the causal part number with a quantity of zero.

DESCRIPTION	SRO	TIME (HOURS)	CONDITION CODE	CAUSAL PART
Repair for B-pillar upper panel creak -				

Pair	<b>76.10.89.25</b>	4.1	12	LR061697
------	--------------------	-----	----	----------

 **NOTE: Normal Warranty procedures apply.**

### **SERVICE INSTRUCTION:**

 **NOTE: a locally sourced zinc rich primer must be applied to any bare metal surfaces.**

 **NOTE: any joints sealed as part of the vehicle manufacture must be sealed as part of the repair.**

**1** Make sure that you are aware of all Health and Safety requirements (see TOPIX Workshop Manual section 100-00 General Information - Health and Safety Precautions).

**2**  **CAUTION: use suitable welding blankets to protect the vehicle from any damage before continuing with this bulletin.**

 **CAUTION: make sure no damage is caused to any part of the vehicle.**

Remove the Side Air Curtain Module (see TOPIX Workshop Manual, section 501-20B: Supplemental Restraint System > Side Air Curtain Module).

**3** Identify the three spot welds to be drilled.



**4**  **CAUTION: make sure no damage is caused to any part of the vehicle.**

 **NOTE: repeat this step on both sides of the vehicle.**

Make sure the spot welds that are to be drilled are visible when installing the suitable clamps to the B-pillar.

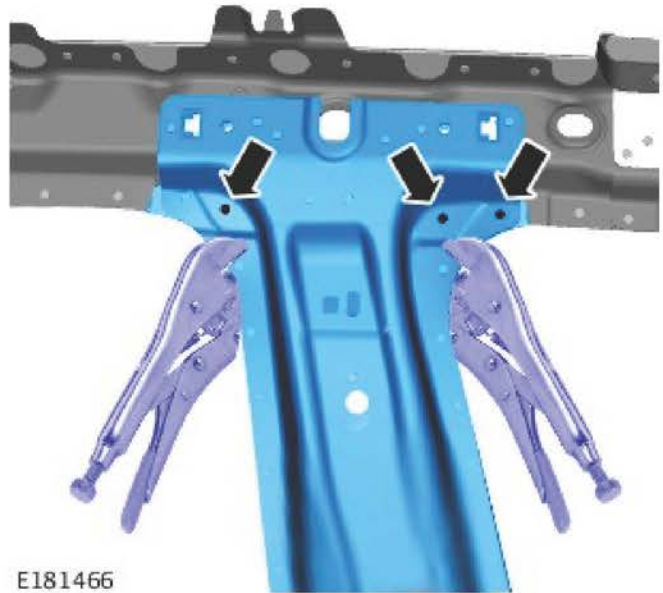

- 5**  **CAUTION:** make sure no damage is caused to any part of the vehicle.

 **NOTE:** repeat this step on both sides of the vehicle.

Drill the three spot welds to the correct depth of 2.5mm.

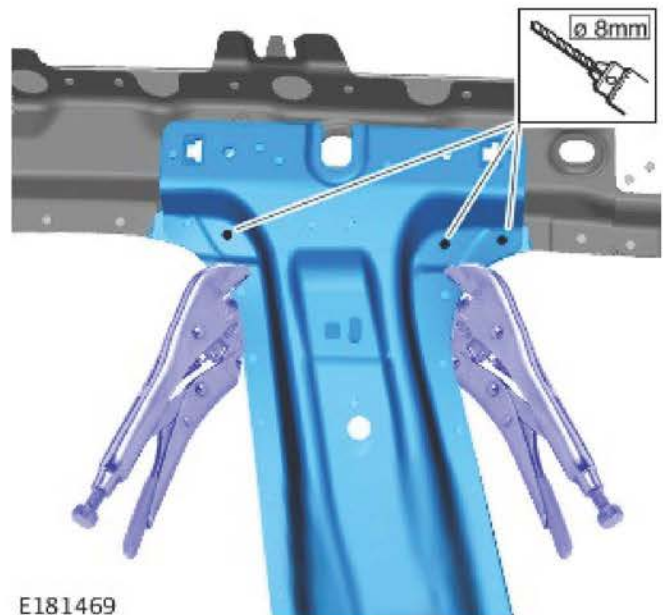

- 6**  **CAUTION:** make sure no damage is caused to any part of the vehicle.

 **NOTE:** repeat this step on both sides of the vehicle.

 **NOTE:** make sure corrosion protection is applied to all areas affected by the repair.

Metal Inert Gas (MIG) weld the three drilled holes.

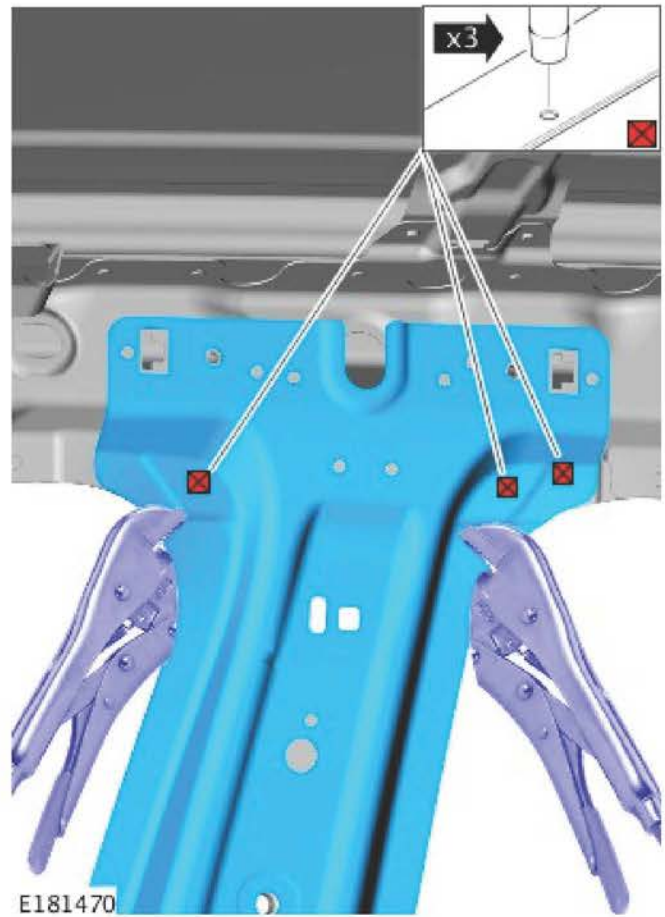

**7**  **CAUTION:** make sure no damage is caused to any part of the vehicle.

 **NOTE:** repeat this step on both sides of the vehicle.

 **NOTE:** make sure corrosion protection is applied to all areas affected by the repair.

MIG seam weld the B-pillar in the area shown.

- Make sure the area between the B-pillar and the inner B-pillar is completely MIG welded in the area shown.

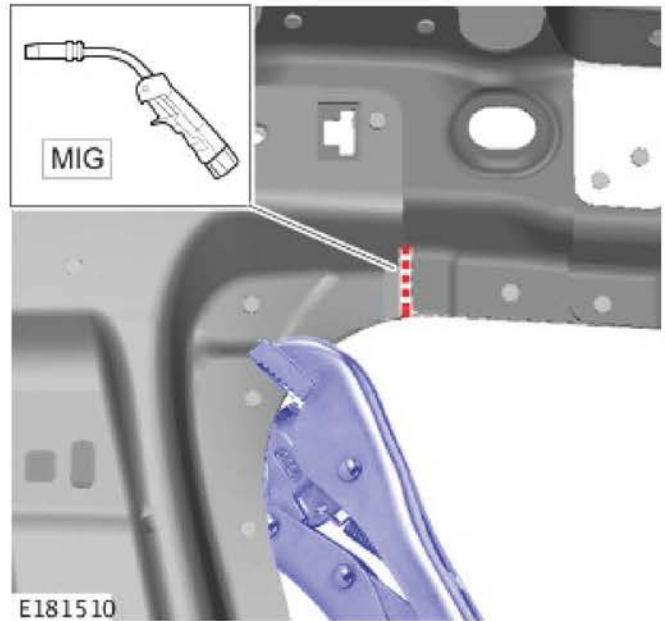

**8**  **CAUTION:** make sure no damage is caused to any part of the vehicle whilst grinding.

 **NOTE:** repeat this step on both sides of the vehicle.

 **NOTE:** make sure corrosion protection is applied to all areas affected by the repair.

Grind away any excess material where the vehicle has been MIG welded.

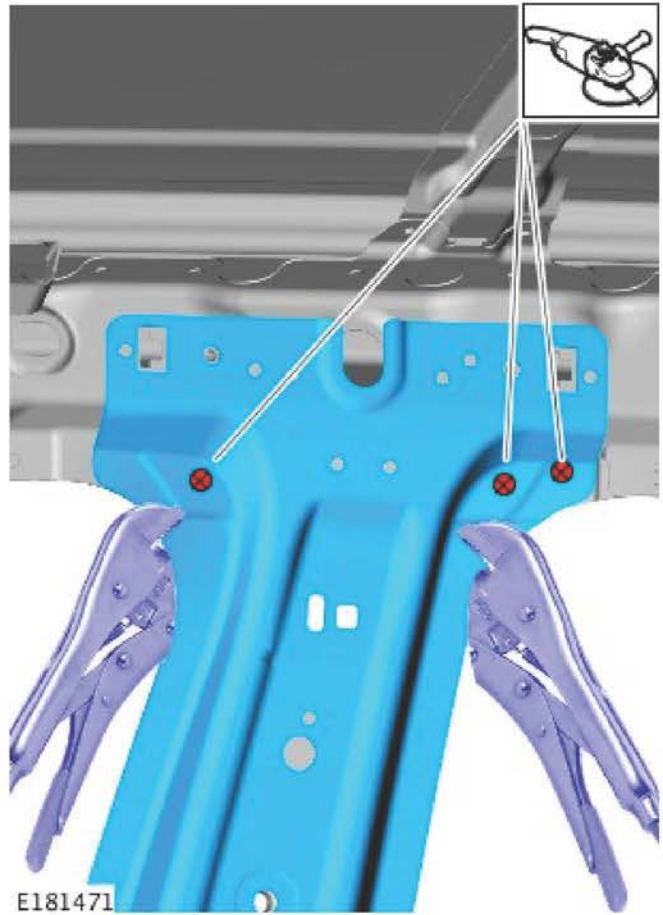

**9**  **CAUTION:** make sure no damage is caused to any part of the vehicle.

 **NOTE:** repeat this step on both sides of the vehicle.

Grind away any excess material where the vehicle has been MIG welded.

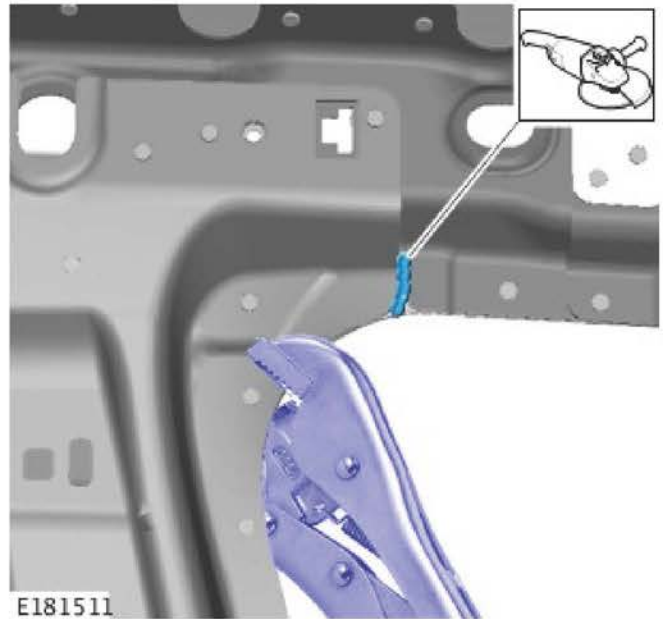

10  **CAUTION:** make sure no damage is caused to any part of the vehicle.

 **NOTE:** repeat this step on both sides of the vehicle.

 **NOTE:** make sure corrosion protection is applied to all areas affected by the repair.

Use a suitable corrosion protection to cover the repaired area.

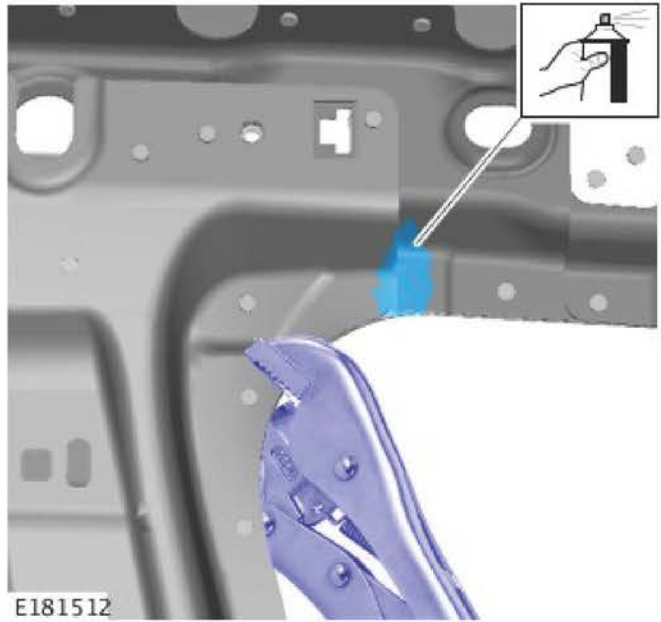

11  **CAUTION:** make sure no damage is caused to any part of the vehicle.

 **NOTE:** repeat this step on both sides of the vehicle.

 **NOTE:** make sure corrosion protection is applied to all areas affected by the repair.

Use a suitable corrosion protection to cover the repaired area.

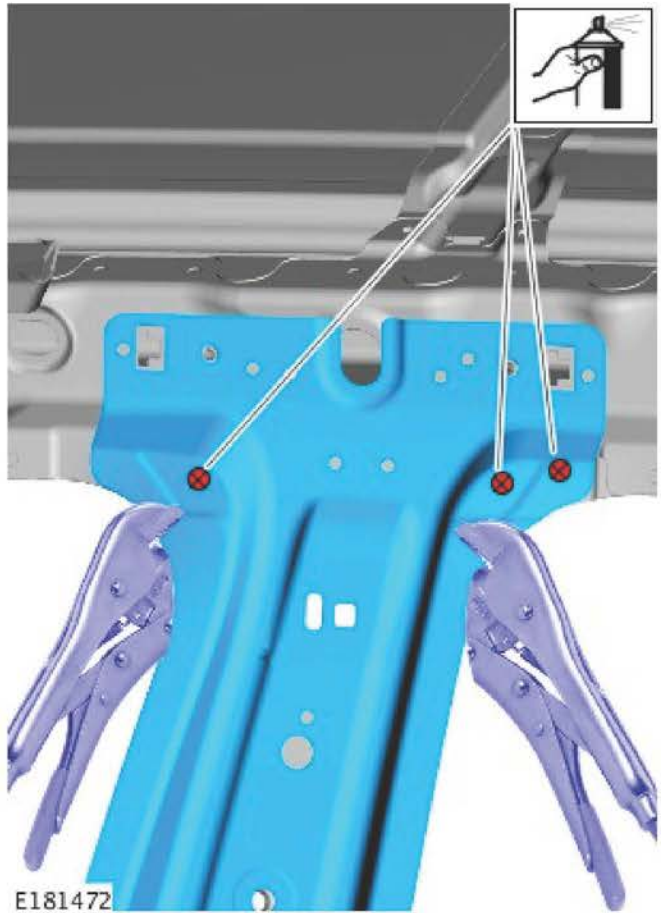

- 12** Install the Side Air Curtain Module (see TOPIx Workshop Manual section 501-20B: Supplemental Restraint System > Side Air Curtain Module).