

© 2015 Mazda Motor of America, Inc.

Subject: 2013-2014 CX-5 - SQUEAKING / GRINDING NOISE FROM REAR BRAKES	Bulletin No: 04-005/15
	Last Issued: 12/04/2015

BULLETIN NOTE

- This bulletin supersedes the previous bulletin 04-005/15, issued on 10/14/15 and 04-003/14, issued on 02/04/14. The WARRANTY INFORMATION has been revised.
- Changes are noted below in Red beside the change bar.

APPLICABLE MODEL(S)/VINS

2013-2014 CX-5 with VINs lower than JM3 KE*****401869 (produced before Oct. 9, 2013)

DESCRIPTION

Some vehicles may exhibit a squeaking / grinding noise from the rear brakes. This noise may be caused by the wear indicators of prematurely worn **outer** rear brake pads.

NOTE: The inner rear brake pads will only show a little wear. This condition only affects the outer rear brake pad(s).

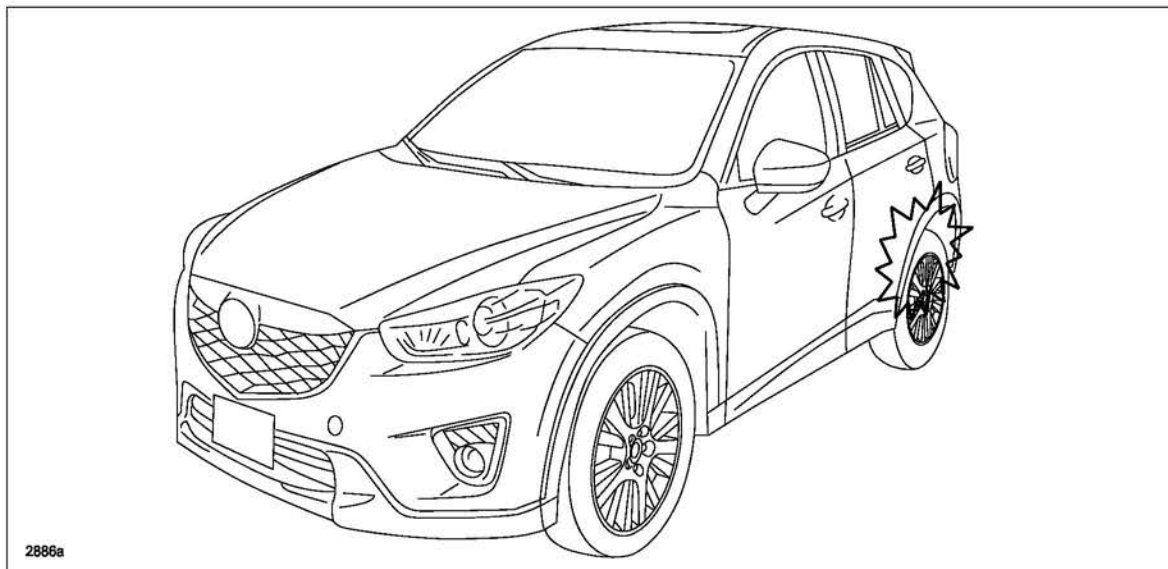

During usage of the vehicle in areas where road salt is used, the **outer** rear brake pad(s) may become stuck due to corrosion. This may cause brake dragging and premature wear to the **outer brake pad(s) only**.

The treatment of the brake pad back plate has been changed to eliminate this concern.

Customers having this concern should have their vehicle repaired using the following repair procedure.

CONSUMER NOTICE: The information and instructions in this bulletin are intended for use by skilled technicians. Mazda technicians utilize the proper tools/equipment and take training to correctly and safely maintain Mazda vehicles. These instructions should not be performed by "do-it-yourselfers." Customers should not assume this bulletin applies to their vehicle or that their vehicle will develop the described concern. To determine if the information applies, customers should contact their nearest authorized Mazda dealership. Mazda North American Operations reserves the right to alter the specifications and contents of this bulletin without obligation or advance notice. All rights reserved. No part of this bulletin may be reproduced in any form or by any means, electronic or mechanical---including photocopying and recording and the use of any kind of information storage and retrieval system ---without permission in writing.

REPAIR PROCEDURE

1. Verify the customer concern.
2. Remove the rear brake caliper supports and rear brake pads according to the instructions on MS3 online or the Workshop Manual (section 04-11 DISC PAD (REAR) REPLACEMENT).
3. Visually inspect the rear brake disc plate(s) for damage.
 - If disc plate damage exists, replace it with a new one according to the instructions on MS3 online or the Workshop Manual (section 04-11 REAR BRAKE (DISC) REMOVAL/INSTALLATION).
4. Remove all rust from the rear brake caliper support area, then apply grease.
NOTE: Refer to "Rust Removal and Grease Application Procedure" below.

5. Install retainers to the rear caliper supports.
6. Install brake pad attachments to the rear brake pad.
7. Install modified rear brake pads.
8. Verify the repair.

Rust Removal and Grease Application Procedure:

1. Remove the brake pads and retainers (A) from the rear brake caliper support and discard them.

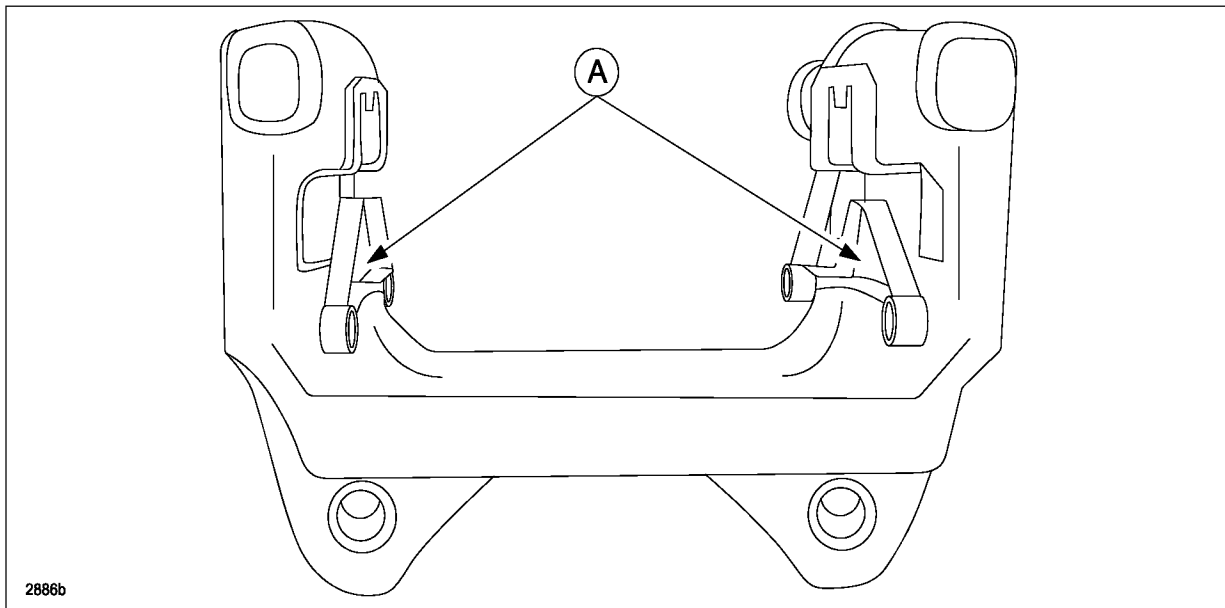

2886b

- Using a wire brush, remove all rust from the rear brake caliper support area (A) until the surface turns glossy (B).

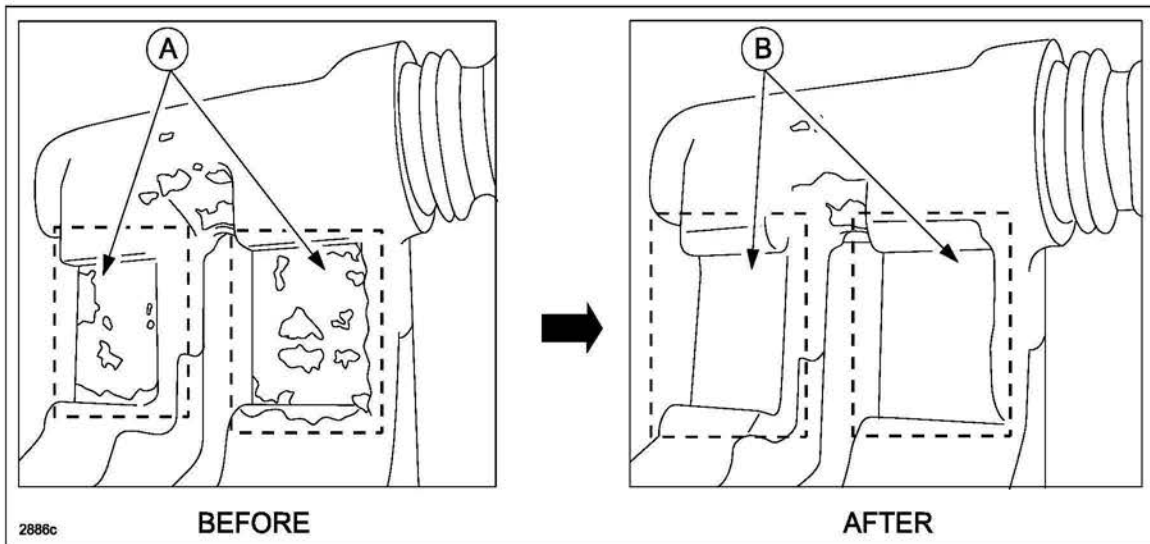

- Wipe the area clean, then apply black grease to the area (A) as shown below.

NOTE: Use the black grease included in the rear brake pad sub set / rear brake pad attachment.

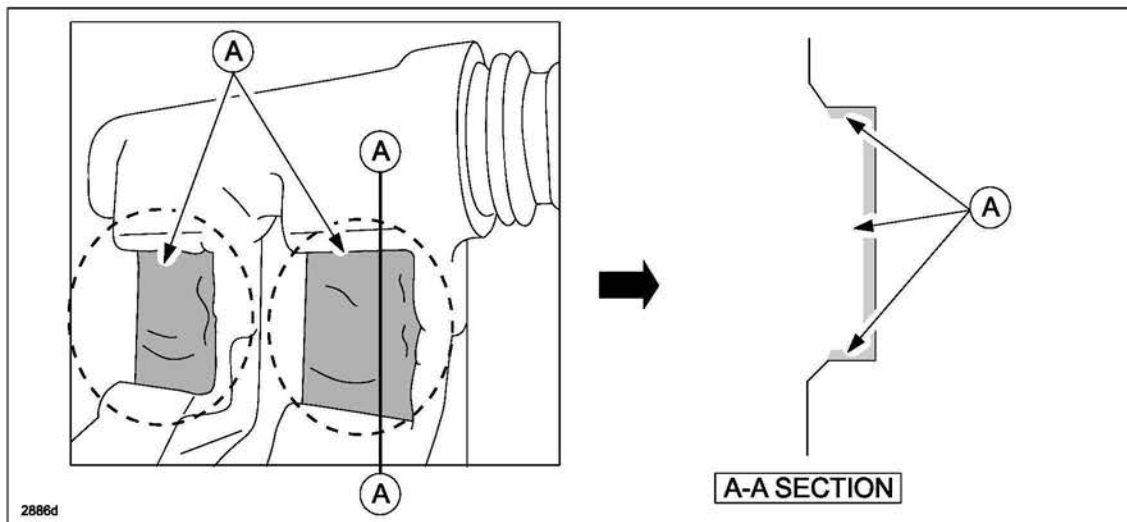

PART(S) INFORMATION

Part Number	Description	Qty.	Notes
K0Y1-26-43ZC	Rear Brake Pad and Attachment Set	1	New service part includes A and B
K011-26-251B	Rear Brake Disc Plate	1 or 2	Replace if necessary

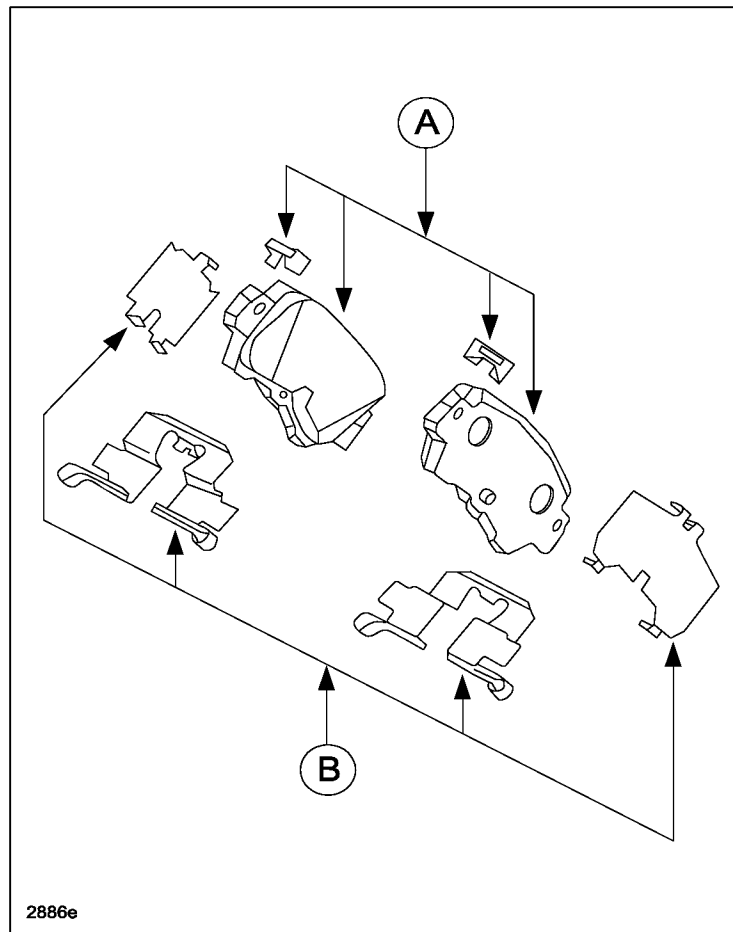

WARRANTY INFORMATION

NOTE:

- This warranty information applies only to verified customer complaints on vehicles eligible for warranty repair.
- **This bulletin is not limited to vehicles under 12 months / 12,000 miles.**
- This repair will be covered under Mazda's New Vehicle Limited Warranty term of **36 months / 36,000 miles.**
- Additional diagnostic time cannot be claimed for this repair.

1. When "Rear Brake Pad and Attachment Set" is used:

1-1. When rear brake disc plate was NOT replaced.	
Warranty Type	A
Symptom Code	82
Damage Code	92
Part Number Main Cause	K0Y1-26-43ZC
Quantity	1
Operation Number / Labor Hours:	XXK31ARX / 0.6 Hrs.

1-2. When one or both rear brake disc plate(s) were replaced:	
Warranty Type	A
Symptom Code	82
Damage Code	92
Part Number Main Cause	K0Y1-26-43ZC
Quantity	1
Operation Number / Labor Hours:	XXK31BRX / 0.7 Hrs.

NOTE: Enter K011-26-251B (Rear Brake Disc Plate) in Related Parts.

2. When separate parts (Rear Brake Pad Sub Set and Rear Brake Pad Attachment) are used:

2-1. When rear brake disc plate was NOT replaced.

Warranty Type	A
Symptom Code	82
Damage Code	92
Part Number Main Cause	K0Y1-26-49ZA
Quantity	1
Operation Number / Labor Hours:	XXK31ARX / 0.6 Hrs.

NOTE: Enter K0Y1-26-48ZC (Rear Brake Pad Sub Set) in Related Parts.

2-2. When one or both rear brake disc plate(s) were replaced:

Warranty Type	A
Symptom Code	82
Damage Code	92
Part Number Main Cause	K0Y1-26-49ZA
Quantity	1
Operation Number / Labor Hours:	XXK31BRX / 0.7 Hrs.

NOTE: Enter K0Y1-26-48ZC (Rear Brake Pad Sub Set) in Related Parts.

NOTE: Enter K011-26-251B (Rear Brake Disc Plate) in Related Parts.