

© 2015 Mazda Motor of America, Inc.

<b>Subject:</b> RATTLE NOISE FROM HEADER PANEL OF CONVERTIBLE TOP	<b>Bulletin No:</b> 09-045/15
	<b>Last Issued:</b> 12/04/2015

## APPLICABLE MODEL(S)/VINS

2016 MX-5 vehicles with VINs lower than JM1ND\*\*\*\*\*107384 (produced before October 26, 2015)

## DESCRIPTION

Some vehicles may exhibit a rattle noise (A) from the header panel (B) of the convertible top when driving on a rough road.

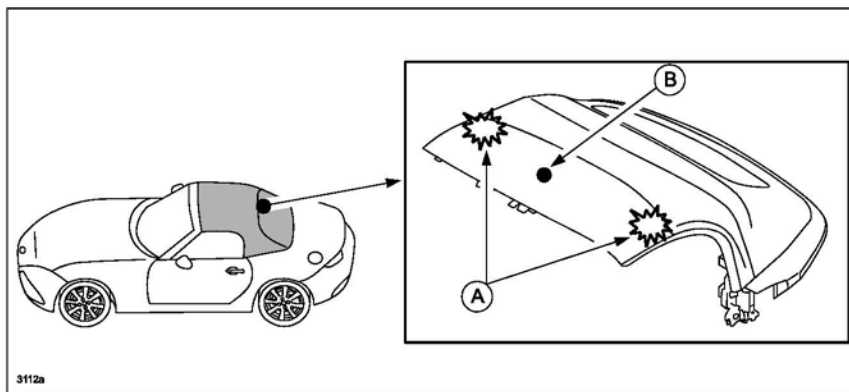

The header panel (A) is formed by two aluminum panels, inner (B) and outer (C). When receiving an input force by driving on a rough road, the two panels at the problem area, where spot welds are located (D), may warp and change relative position causing the rattling noise. (F=Front)

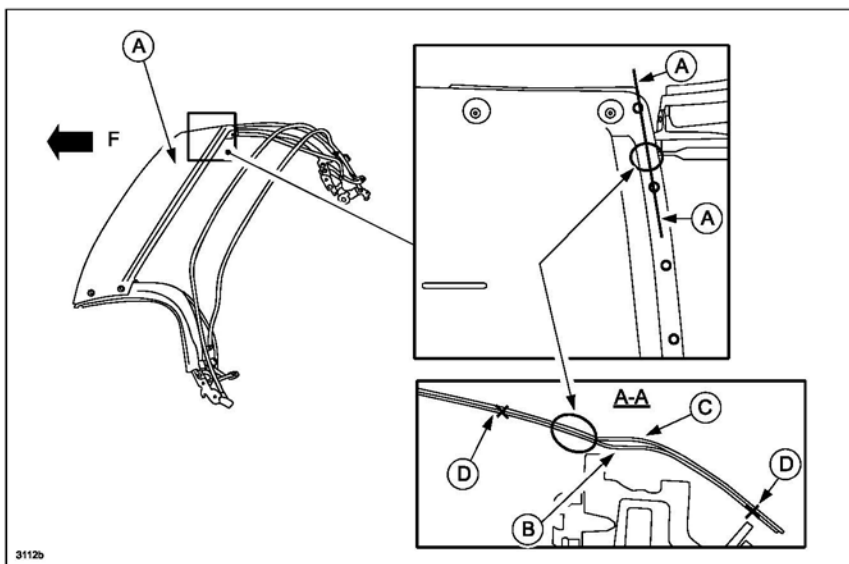

**CONSUMER NOTICE:** The information and instructions in this bulletin are intended for use by skilled technicians. Mazda technicians utilize the proper tools/equipment and take training to correctly and safely maintain Mazda vehicles. These instructions should not be performed by "do-it-yourselfers." Customers should not assume this bulletin applies to their vehicle or that their vehicle will develop the described concern. To determine if the information applies, customers should contact their nearest authorized Mazda dealership. Mazda North American Operations reserves the right to alter the specifications and contents of this bulletin without obligation or advance notice. All rights reserved. No part of this bulletin may be reproduced in any form or by any means, electronic or mechanical---including photocopying and recording and the use of any kind of information storage and retrieval system ---without permission in writing.

To correct the problem, a spot weld (E) has been added to the problem area, where the original spot welds are located (D), to increase the rigidity and prevent the warping.

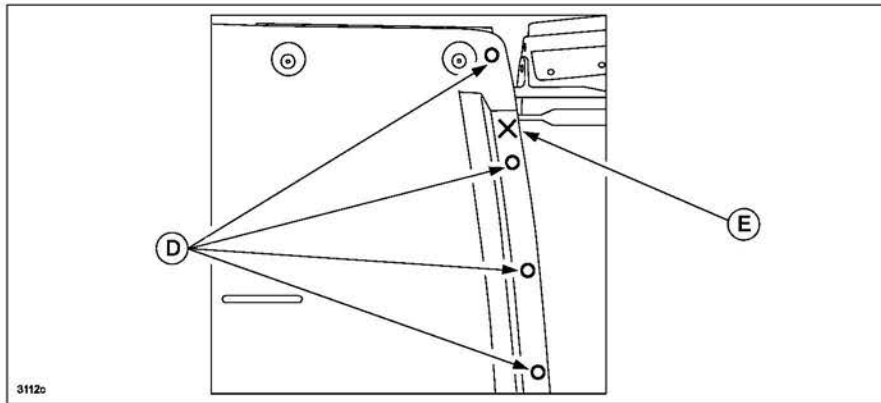

Customers having this concern should have their vehicle repaired using the following repair procedure.

### REPAIR PROCEDURE

1. Verify customer concern.
2. Enlarge the gap between the inner and outer panel of the header panel at the problem area (both driver and passenger sides) using the following procedure.
  - a. Open the convertible top to a position where the area to work (A) is the most accessible as shown.



- b. Using a flat-blade screwdriver with protection tape on the tip, enlarge the gap between the outer (A) and inner (B) aluminum panel of the header panel about 1-2mm at the problem area.

**CAUTION:** Make sure not to damage the soft top when using the flat-blade screwdriver.

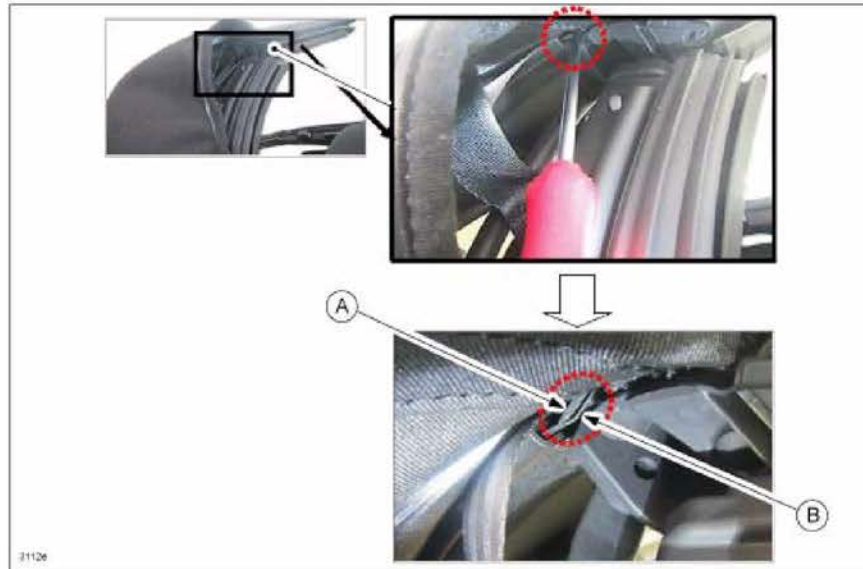

3. Verify repair.

## WARRANTY INFORMATION

### NOTE:

- This warranty information applies only to verified customer complaints on vehicles eligible for warranty repair.
- This repair will be covered under Mazda's New Vehicle Limited Warranty.
- Additional diagnostic time cannot be claimed for this repair.

Warranty Type	A
Symptom Code	82 (Unusual Noise)
Damage Code	9B (Warped)
Part Number Main Cause	N243-R1-100G (Link, Soft Top)
Quantity	0
Operation Number / Labor Hours	XXL9CXRX / 0.3 Hrs.