

© 2015 Mazda Motor of America, Inc.

Subject: NOISE FROM FUEL TANK INSULATOR	Bulletin No: 01-010/15
	Last Issued: 12/14/2015

BULLETIN NOTE

- This bulletin supersedes the previous bulletin 01-010/15, issued on 05/26/15. The APPLICABLE MODEL(S)/VINS and PART(S) INFORMATION has been revised.
- Changes are noted below in Red beside the change bar.

APPLICABLE MODEL(S)/VINS

2010-2015 CX-9 vehicles with VINs lower than JM3TB*****460027 (produced before April 1, 2015)

DESCRIPTION

Some vehicles may exhibit an unusual noise while driving the vehicle. The noise may be caused by a broken fuel tank (B) insulator (A) that is hanging down and contacting the propeller shaft.

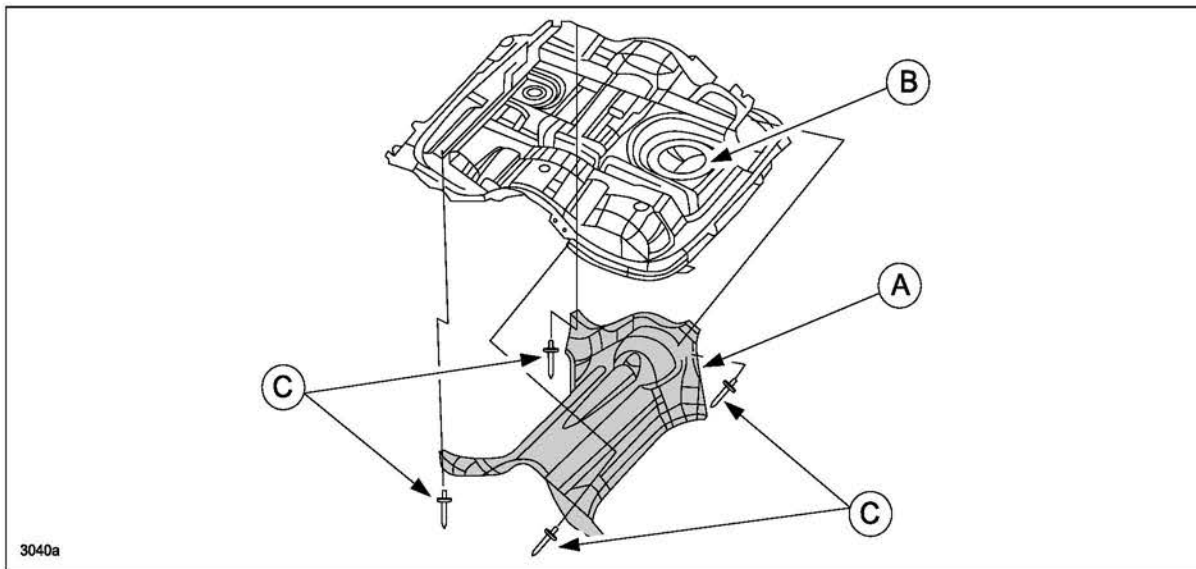

The rivets (C) may break when a load occurs. The rivet material has been changed to eliminate this concern. Customers having this concern should have their vehicle repaired using the following repair procedure.

REPAIR PROCEDURE

1. Verify the customer concern.
2. Safely raise the vehicle on a hoist, then inspect the insulator for damaged at the rivet(s).
3. Remove the pre-silencer from the vehicle according to the instructions on MS3 online or the Workshop Manual (section 01-15 EXHAUST SYSTEM REMOVAL/INSTALLATION [MZI-3.7]).

NOTE: (4WD Only): Disconnect the propeller shaft from the differential.

4. Remove and discard the insulator from the fuel tank.

CAUTION: When removing the rivet pins using a drill, pay close attention not to damage the fuel tank.

5. Install the new insulator with modified rivets.

6. Re-install the pre-silencer according to the instructions on MS3 online or the Workshop Manual (section 01-15 EXHAUST SYSTEM REMOVAL/INSTALLATION [MZI-3.7]).

NOTE: (4WD Only): Re-connect the propeller shaft to the differential.

7. Verify the repair.

PART(S) INFORMATION

Part Number	Description	Qty.	Notes
TK31-56-398	Rivet	5	---
L214-42-741A	Insulator	1	4WD
L206-42-741A	Insulator	1	2WD
FSB8-40-305	Gasket	2	Replacement parts
AJ17-40-305	Gasket	1	---

WARRANTY INFORMATION

NOTE:

- This warranty information applies only to verified customer complaints on vehicles eligible for warranty repair.
- This repair will be covered under Mazda's New Vehicle Limited Warranty term.
- Additional diagnostic time cannot be claimed for this repair.

Warranty Type	A
Symptom Code	82
Damage Code	9A
Part Number Main Cause	TK31-56-398
Quantity	5
Operation Number / Labor Hours:	XXL3CARX / 0.7 Hrs. - (2WD) XXL3CBRX / 0.8 Hrs. - (4WD)