

TECHNICAL BULLETIN
LTB00671NAS4
10 AUG 2015



© Jaguar Land Rover North America, LLC

NOTE: The information in Technical Bulletins is intended for use by trained, professional Technicians with the knowledge, tools, and equipment required to do the job properly and safely. It informs these Technicians of conditions that may occur on some vehicles, or provides information that could assist in proper vehicle service. The procedures should not be performed by 'do-it-yourselfers'. If you are not a Retailer, do not assume that a condition described affects your vehicle. Contact an authorized Land Rover service facility to determine whether this bulletin applies to a specific vehicle.

This reissue replaces all previous versions. Please destroy all previous versions.

Changes are highlighted in gray

SECTION: 303-14

Engine MIL Illuminated With Heated Oxygen Sensor-Related DTCs Stored

AFFECTED VEHICLE RANGE:

LR4 (LA) Model Year: 2014-2016 VIN: 679426-784564 Manufacturing Plant: Solihull	
Range Rover Sport (LW) Model Year: 2014 VIN: 000002-504508 Manufacturing Plant: Solihull	Engine: V6 S/C 3.0L Petrol
Range Rover Sport (LW) Model Year: 2014 VIN: 600009-601758 Manufacturing Plant: Solihull	Engine: V6 S/C 3.0L Petrol
Range Rover Sport (LW) Model Year: 2015 VIN: 504358-542163 Manufacturing Plant: Solihull	Engine: V6 S/C 3.0L Petrol
Range Rover Sport (LW) Model Year: 2015 VIN: 600178-630153 Manufacturing Plant: Solihull	Engine: V6 S/C 3.0L Petrol
Range Rover (LG) Model Year: 2014-2015 VIN: 110440-243370 Manufacturing Plant: Solihull	Engine: V6 S/C 3.0L Petrol

MARKETS:

NAS

CONDITION SUMMARY:

Situation: On vehicles fitted with the 3.0L SC V6 engine only, the engine Malfunction Indicator Lamp (MIL) may be illuminated. Upon diagnosis, the technician may find one or more Diagnostic Trouble Code (DTC), listed in the table below and relevant to the heated oxygen sensors (HO2S), may be stored in the Engine Control Module (ECM).

Cause: This may be caused by thermal shock when water contacts the heated sensing element.

Action: Should a customer express this concern, follow the Service Instruction outlined below.

PARTS:



NOTE: quantity listed refers to the number of oxygen sensors installed on the vehicle, NOT necessarily the number required for the repair.

LR035750	Pre-catalyst oxygen sensor - All vehicles	Quantity: 2
LR035746	Mid-catalyst oxygen sensor - Left - All vehicles EXCEPT Range Rover Sport (L494); Range Rover (L405) - 2015MY-onwards - SULEV NAS only	Quantity: 1
LR052424	Mid-catalyst oxygen sensor - Right - LR4 (L319)	Quantity: 1
LR035747	Mid-catalyst oxygen sensor - Right - Range Rover Sport (L494); Range Rover (L405) EXCEPT 2015MY-onwards - SULEV NAS only	Quantity: 1
LR062826	Mid-catalyst oxygen sensor - Right - Range Rover Sport (L494); Range Rover (L405) - 2015MY-onwards - SULEV NAS only	Quantity: 1
LR062827	Mid-catalyst oxygen sensor - Left - Range Rover Sport (L494); Range Rover (L405) - 2015MY-onwards - SULEV NAS only	Quantity: 1
LR052426	Post-catalyst oxygen sensor - Right - LR4 (L319)	Quantity: 1
LR052425	Post-catalyst oxygen sensor - Left - LR4 (L319)	Quantity: 1
LR035748	Post-catalyst oxygen sensor - Range Rover Sport (L494); Range Rover (L405)	Quantity: 2

TOOLS:



NOTE: this is an 'Active Bulletin' that will display a functional programming shortcut if accessed within a diagnostic session using SDD.

SDD with latest DVD and Calibration File
Jaguar Land Rover-approved Midtronics battery power supply

WARRANTY:



NOTE: the 'Engine Control Module' (ECM) may also be referred to as 'Powertrain Control Module' (PCM).



NOTE: Repair procedures are under constant review, and therefore times are subject to change; those quoted here must be taken as guidance only. Always refer to TOPIx to obtain the latest repair time.



NOTE: DDW requires the use of causal part numbers. Labor only claims must show the causal part number with a quantity of zero.

DESCRIPTION	SRO	TIME (HOURS)	CONDITION CODE	CAUSAL PART
Sensor - Heated Oxygen (HO2S) - Pre-catalyst - Right - Renew - LR4 (L319)	17.50.42	1.6	04	LR035750
Sensor - Heated Oxygen (HO2S) - Pre-catalyst - Left - Renew - LR4 (L319)	17.50.39	1.6	04	LR035750
Sensor - Heated Oxygen (HO2S) - Mid-catalyst - Right - Renew - LR4 (L319)	17.50.43	0.3	04	LR052424
Sensor - Heated Oxygen (HO2S) - Mid-catalyst - Left - Renew - LR4 (L319)	17.50.40	0.2	04	LR035746
Sensor - Heated Oxygen (HO2S) - Post-catalyst - Right - Renew - LR4 (L319)	17.50.44	0.1	04	LR052426
Sensor - Heated Oxygen (HO2S) - Post-catalyst - Left - Renew - LR4 (L319)	17.50.41	0.1	04	LR052425

Sensor - Heated Oxygen (HO2S) - Pre-catalyst - Right - Renew - Range Rover Sport (L494)	17.50.42	1.8	04	LR035750
Sensor - Heated Oxygen (HO2S) - Pre-catalyst - Left - Renew - Range Rover Sport (L494)	17.50.39	1.8	04	LR035750
Sensor - Heated Oxygen (HO2S) - Mid-catalyst - Right - Renew - Range Rover Sport (L494); Range Rover (L405)	17.50.43	0.4	04	LR035747
Sensor - Heated Oxygen (HO2S) - Mid-catalyst - Left - Renew - Range Rover Sport (L494); Range Rover (L405)	17.50.40	0.3	04	LR035746
Sensor - Heated Oxygen (HO2S) - Post-catalyst - Right - Renew - Range Rover Sport (L494); Range Rover (L405)	17.50.44	0.1	04	LR035748
Sensor - Heated Oxygen (HO2S) - Post-catalyst - Left - Renew - Range Rover Sport (L494); Range Rover (L405)	17.50.41	0.1	04	LR035748
Sensor - Heated Oxygen (HO2S) - Pre-catalyst - Right - Renew - Range Rover (L405)	17.50.42	1.9	04	LR035750
Sensor - Heated Oxygen (HO2S) - Pre-catalyst - Left - Renew - Range Rover (L405)	17.50.39	1.9	04	LR035750
Configure existing module - Engine Control Module	12.90.13	0.2	04	LR038618



NOTE: Normal Warranty procedures apply.

Diagnostic Trouble Code (DTC) Information

Diagnostic Trouble Codes Relating to this Issue



NOTE: only base DTC data listed; third byte data not listed.

Diagnostic Trouble Code (DTC) List	Affected Heated Oxygen Sensor (HO2S)
P0030, P0031, P00D1, P0130, P0131, P0132, P0133, P0134, P0135, P014C, P2195, P2196, P2231, P2237, P2243, P2245, P2251, P2297, P2626, P2A00	Heated Oxygen Sensor (HO2S) - Pre-catalyst - Bank 1, Sensor 1 (B1-S1)
P0050, P0051, P00D3, P0150, P0151, P0152, P0153, P0154, P0155, P2197, P2198, P2234, P2240, P2247, P2254	Heated Oxygen Sensor (HO2S) - Pre-catalyst - Bank 2, Sensor 1 (B2-S1)
P0037, P0038, P0054, P0136, P0137, P0138, P0139, P013A, P013E, P0140, P0141, P2270, P2271	Heated Oxygen Sensor (HO2S) - Mid-catalyst - Bank 1, Sensor 2 (B1-S2)
P0056, P0057, P0060, P013C, P014A, P0156, P0157, P0158, P0159, P0160, P0161, P2272, P2273	Heated Oxygen Sensor (HO2S) - Mid-catalyst - Bank 2, Sensor 2 (B2-S2)
P0042, P0043, P0044, P0055, P0142, P0143, P0144, P0147, P2274, P2275	Heated Oxygen Sensor (HO2S) - Post-catalyst - Bank 1, Sensor 3 (B1-S3)
P0061, P0062, P0063, P0162, P0163, P0164, P0167, P2276, P2277	Heated Oxygen Sensor (HO2S) - Post-catalyst - Bank 2, Sensor 3 (B2-S3)

Heated Oxygen Sensor (HO2S) Location and Designation



1. NOTE: engine is shown viewed from above.

Heated Oxygen Sensor (HO2S) location and designation.

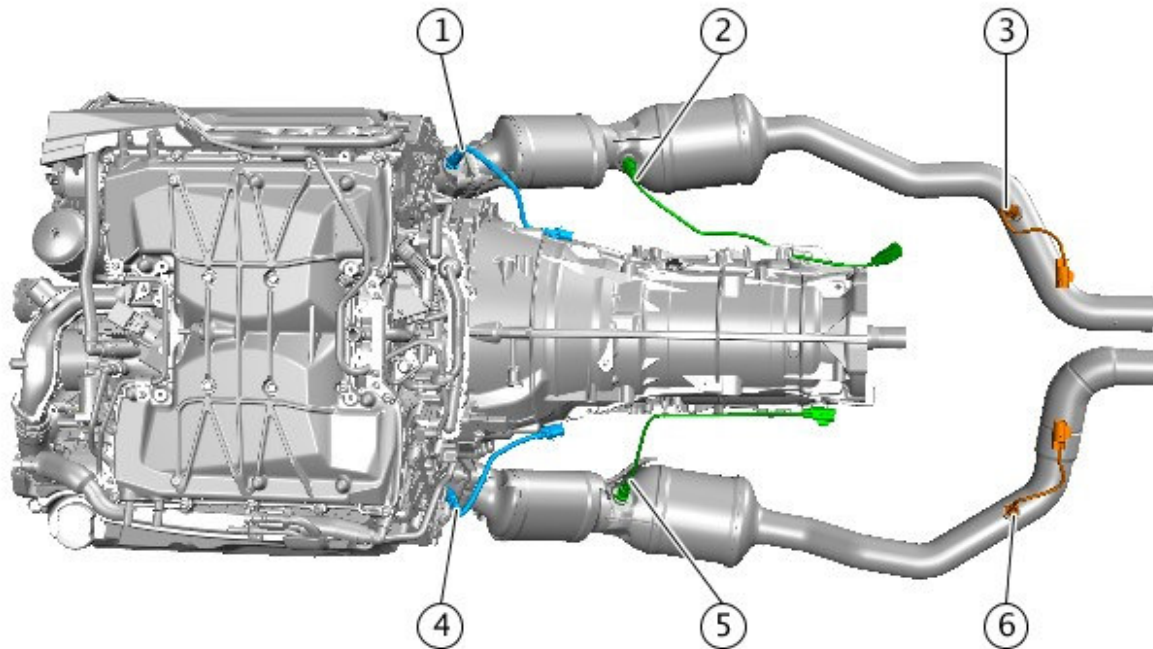

E181489

HO2S	Description	Identification
1	Heated Oxygen Sensor (HO2S) - Pre-catalyst - Bank 1, Sensor 1	B1-S1
2	Heated Oxygen Sensor (HO2S) - Mid-catalyst - Bank 1, Sensor 2	B1-S2
3	Heated Oxygen Sensor (HO2S) - Post-catalyst - Bank 1, Sensor 3	B1-S3
4	Heated Oxygen Sensor (HO2S) - Pre-catalyst - Bank 2, Sensor 1	B2-S1
5	Heated Oxygen Sensor (HO2S) - Mid-catalyst - Bank 2, Sensor 2	B2-S2
6	Heated Oxygen Sensor (HO2S) - Post-catalyst - Bank 2, Sensor 3	B2-S3

SERVICE INSTRUCTION:

⚠ CAUTION: a Jaguar Land Rover-approved Midtronics battery power supply must be connected to the vehicle battery during SDD diagnosis / module programming.

⚠ CAUTION: ensure all ignition 'ON' / ignition 'OFF' requests are carried out; failure to perform these steps may cause damage to control modules in the vehicle.

⚠ NOTE: SDD must be loaded with DVD142.05 v.214 or later.

1. Connect the Jaguar Land Rover-approved Midtronics battery power supply to the vehicle battery.
2. Turn ignition 'ON' (engine not running).
3. Connect the Symptom Driven Diagnostics (SDD) system to the vehicle and begin a new session.

4. Follow the on-screen prompts, allowing SDD to read the VIN and identify the vehicle and initiating the data collect sequence.

5. Read Diagnostic Trouble Codes (DTC).

6. Exit the current session.

7.  **NOTE: only the affected Heated Oxygen Sensor(s) (HO2S) should be replaced as per the Diagnostic Trouble Code (DTC) stored in the Engine Control Module (ECM). It is very unlikely for both sensors to fail simultaneously. The new software will prevent any further concerns.**

Replace the affected Heated Oxygen Sensor(s) (HO2S) (see TOPIx Workshop Manual, section 303-14).

 **NOTE: one or more of the Diagnostic Trouble Codes (DTC) from the list above must be set in the Engine Control Module (ECM).**

 **NOTE: the 'Engine Control Module' (ECM) may also be referred to as 'Powertrain Control Module' (PCM).**

8. Connect the Symptom Driven Diagnostics (SDD) system to the vehicle and begin a new session.

9. Follow the on-screen prompts, allowing SDD to read the VIN and identify the vehicle and initiating the data collect sequence.

10. Select 'Diagnosis' from the Session Type screen.

11. Select the 'Selected Symptoms' tab, and then select:

- Electrical > Instruments > Warning lamps > Engine malfunction lamp > Lamp illuminated

12. Select 'continue'.

13. Select the 'Recommendations' tab, and then select '**Run**' to perform the 'Configure existing module – Powertrain control module' option.

14. Follow all on-screen instructions to complete this task, ensuring all DTCs are cleared.

15. Exit the current session.

16. Disconnect the SDD and the battery power supply from the vehicle.