

© 2015 Mazda Motor of America, Inc.

Subject: UNUSUAL NOISE WHEN STARTING TO MOVE VEHICLE WHILE STEERING WHEEL IS TURNED TO FULL LEFT POSITION	Bulletin No: 06-001/15
	Last Issued: 10/07/2015

BULLETIN NOTE

- This bulletin supersedes the previous bulletin 06-001/15, issued on 07/21/15 and 08/12/15, 06-002/14, issued on 07/29/14 and 06-002/13, issued on 10/09/13. The WARRANTY INFORMATION has been revised.
- Changes are noted below in Red beside the change bar.

APPLICABLE MODEL(S)/VINS

2014-2015 Mazda3 vehicles with VINs lower than JM1BM*****233957 (produced Sept. 22, 2014)

2014-2015 Mazda6 vehicles with VINs lower than JM1GJ*****210201 (produced Sept. 22, 2014)

2013-2015 CX-5 vehicles with VINs lower than JM3KE*****531471 (produced Sept. 22, 2014)

DESCRIPTION

Some vehicles may exhibit an unusual thumping noise from under the front of the vehicle. This noise only occurs when starting to move the vehicle while the steering wheel is turned to the full left position.

NOTE: The noise will not occur if the steering wheel is in the center or full right position.

The noise is caused when the edge of the left side inner ball joint gets stuck with the steering gear housing.



To eliminate the noise, the shape of the inner ball joint edge has been changed.

Customers having this concern should have their vehicle repaired using the following repair procedure.

REPAIR PROCEDURE

1. Verify the customer concern by turning the steering wheel full left, then start moving the vehicle.
 - If the noise is not present, this service information does not apply.
 - If the noise is present, replace the driver's-side tie rod assembly with a modified part.
2. Remove the left front lower control arm (A) according to the on-line instructions on MS3 or the Workshop Manual (section 02-13 FRONT LOWER ARM REMOVAL/INSTALLATION).

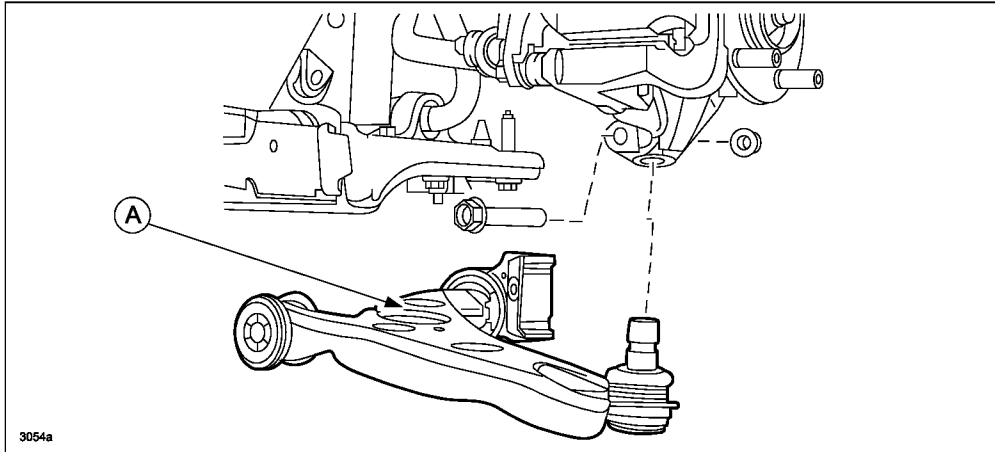

3. Remove the driver's side (A) tie-rod end (B) boot band and (C) boot from the steering rack.

CAUTION: Using shop air, blow the surrounding area clean before removing the boot to prevent dust and debris from adhering to the steering gear.

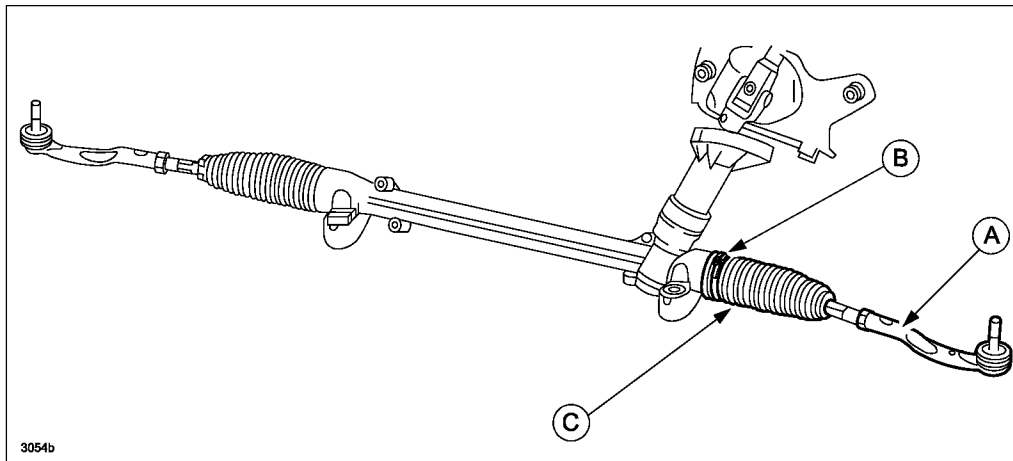

4. Insert a flathead screwdriver into the boot band (as shown below), then press the caulked area outward to remove the boot band.

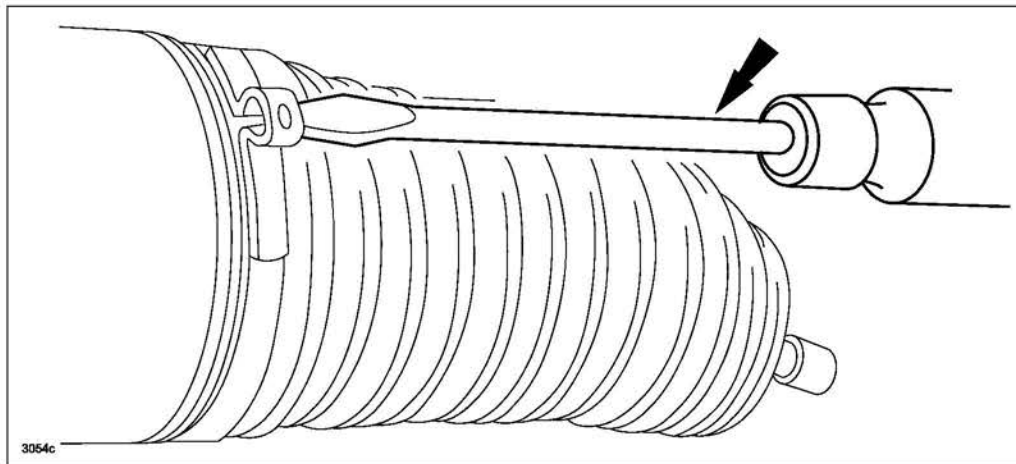

5. Remove the boot from the steering gear.
6. Lock the steering gear end (pinion gear side) with a suitable wrench to prevent rotation.

NOTE: The steering gear is shown below removed from the vehicle for illustrative purposes only. It is not necessary to remove the steering gear from the vehicle.



7. Remove the tie-rod.
8. Install a modified tie rod assembly to the steering gear.
Tightening Torque: 70 - 95 Nm {52 - 70 ft. lbf., 9.6 - 13 kgfm}

- Squeeze approx. 1cc of grease out of the tube onto your finger.



- Apply the grease all the way around the inner ball joint edge (as shown below).



- Reinstall the boot using a new boot band.

NOTE: Tighten the boot band until the clearance between the ends of the band are 2-4 mm (as shown below).



- Reinstall parts in the reverse order of removal.
- Verify the repair.

PART(S) INFORMATION

Part Number	Description	Qty.	Notes
GHY2-32-24X	Inner Ball Joint Assy.	1	Mazda3 / Mazda6
KDY1-32-24X	Inner Ball Joint Assy.	1	CX-5
BHY1-32-GR1	Grease	1	One (1) tube repairs twenty (20) vehicles

NOTE:

- GHY2-32-24X / KDY1-32-24X: includes inner ball Joint, wire clamp and snap pin.
- The cost of the grease is included in the labor time.

WARRANTY INFORMATION

NOTE:

- This warranty information applies only to verified customer complaints on vehicles eligible for warranty repair.
- This repair will be covered under the New Vehicle Limited Warranty term.
- Additional diagnostic time cannot be claimed for this repair.

Warranty Type	A
Symptom Code	82
Damage Code	9M
Part Number Main Cause	GHY2-32-24X (Mazda3 / Mazda6) or KDY1-32-24X (CX-5)
Quantity	1
Operation Number / Labor Hours	XXL27XRX / 0.8 Hrs.

NOTE: Add the wheel alignment with the following information.

Operation Number	Labor Hours	Work	Applicable Models
A0109AAX	1.1	Wheel Alignment, Check and Adjust using Wire type 4-wheel alignment machine.	CX-5, Mazda3 and Mazda6
XXL27ARX	0.7	Wheel Alignment, Check and Adjust using Wireless type 4-wheel alignment machine.	CX-5, Mazda3 and Mazda6

NOTE: If the wheel alignment is performed by an external repair shop, submit the invoice as a sublet.