

© 2015 Mazda Motor of America, Inc.

Subject: WATER ENTRY INTO TRUNK LID LIGHT DURING HIGH PRESSURE CAR WASH	Bulletin No: 09-021/15
	Last Issued: 05/27/2015

APPLICABLE MODEL(S)/VINS

2014-2015 Mazda6 vehicles with VINs lower than JM1 GJ ***** 170534 (produced before January 29, 2014)

DESCRIPTION

Some vehicles may exhibit a condition that water enters into the trunk lid light while washing the vehicle with high pressure. Water may enter through the trunk lid light gasket and the body panel.

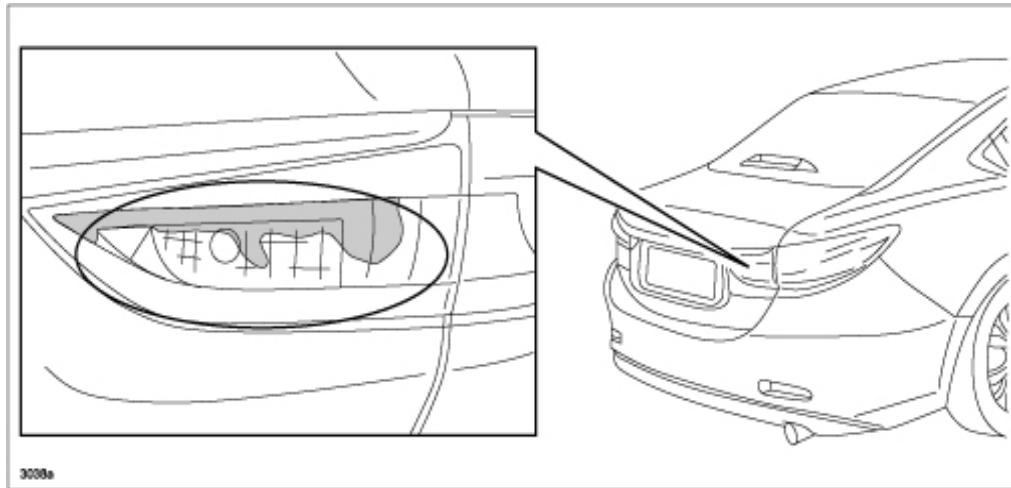

Customers having this concern should have their vehicle repaired using the following repair procedure.

REPAIR OUTLINE

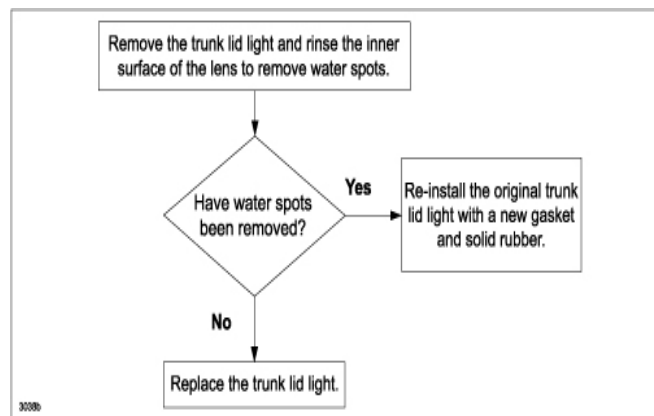

NOTE: New trunk lid light includes gasket and the solid rubber.

CONSUMER NOTICE: The information and instructions in this bulletin are intended for use by skilled technicians. Mazda technicians utilize the proper tools/equipment and take training to correctly and safely maintain Mazda vehicles. These instructions should not be performed by "do-it-yourselfers." Customers should not assume this bulletin applies to their vehicle or that their vehicle will develop the described concern. To determine if the information applies, customers should contact their nearest authorized Mazda dealership. Mazda North American Operations reserves the right to alter the specifications and contents of this bulletin without obligation or advance notice. All rights reserved. No part of this bulletin may be reproduced in any form or by any means, electronic or mechanical---including photocopying and recording and the use of any kind of information storage and retrieval system ---without permission in writing.

REPAIR PROCEDURE

1. Verify customer concern.
2. Is customer concern due to Water Entry or Condensation?
 - a. Water Entry - Go to step 3.
 - b. Condensation - This bulletin does not apply. DO NOT replace the trunk lid light. Explain to the customer that this is a natural phenomenon and not a quality defect. Refer to TSB 09-007/14, CONDENSATION / FOG IN FRONT AND REAR COMBINATION LAMPS.
3. Remove the trunk lid light. Refer to MS3 online or Workshop Manual section 09-18 (TRUNK LID LIGHT REMOVAL/INSTALLATION).
4. Prepare 1.5 liter of hot water [around 104 degrees Fahrenheit (40 degrees Celsius)] per trunk lid light.
5. From the bulb installation hole, pour in just enough hot water (about 400cc) to cover the half level of trunk lid light.
6. Add one or two drop of neutral detergent in the trunk lid light.
NOTE: Use liquid type neutral detergent for dish/hand etc. washing only. DO NOT use alkali or acid type detergent.
7. Plug the bulb installation hole with your thumb then shake the trunk lid light in all directions as shown in the below figure to remove dirt adhering to the lens.

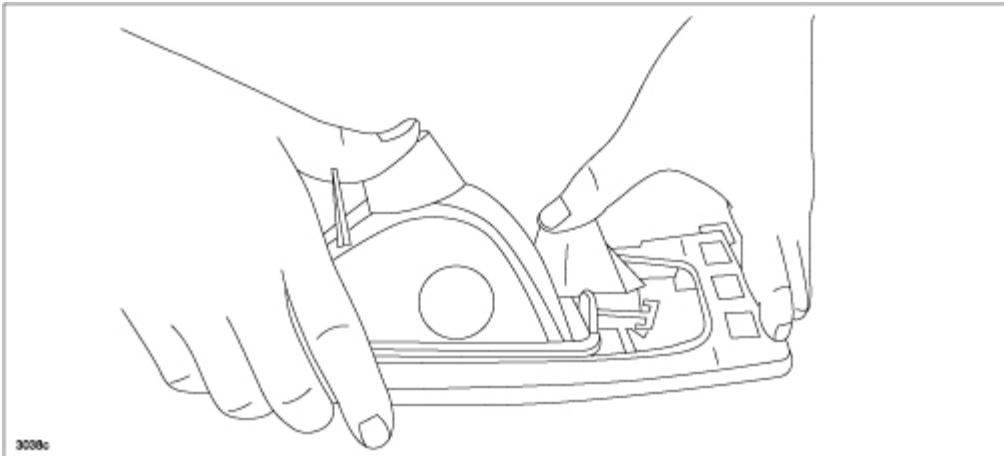

8. Rinse the inside of the trunk lid light with hot water [around 104 degrees Fahrenheit (40 degrees Celsius)] until foam has disappeared.
9. Drain off the water and shake the trunk lid light well until no water drops come out.
10. Are there water drop stains in the inner surface of the lens?
 - No - Proceed to step 11.
 - Yes - Replace the trunk lid light. Refer to MS3 online or Workshop Manual section 09-18 (TRUNK LID LIGHT REMOVAL/INSTALLATION).

NOTE: The new trunk lid light includes the modified gasket and the solid rubber.

11. Use an appropriate air drier (A) to dry the trunk lid light (B) inner lens surface. Position the trunk lid light so that the bulb installation hole is facing down.

CAUTION: Set air drier to the coldest setting. Using hot air could deform the lens.

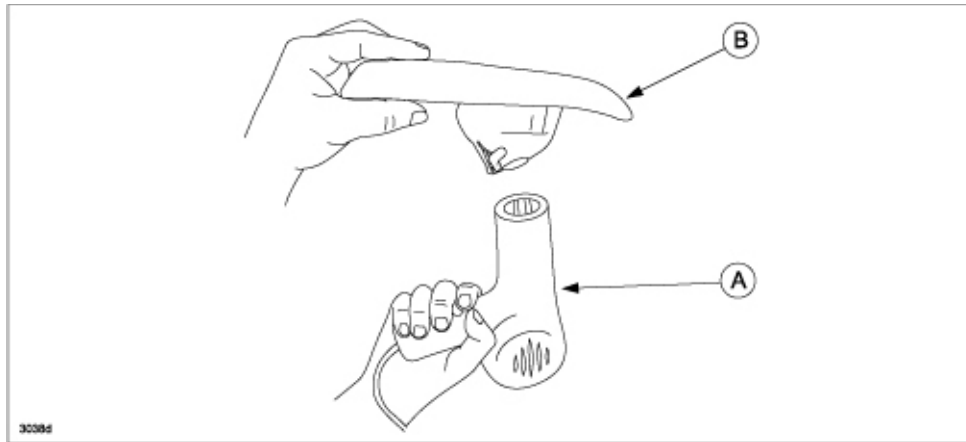

12. Blow air into the trunk lid light bulb installation hole from below until the inner lens surface is completely dry.

CAUTION: Do not use **hot** air. Using hot air could deform the lens.

13. After the inner surface of the lens is dry, remove the gasket (A) from the removed trunk lid light. Remove the packing (B) as well if attached. Discard them.

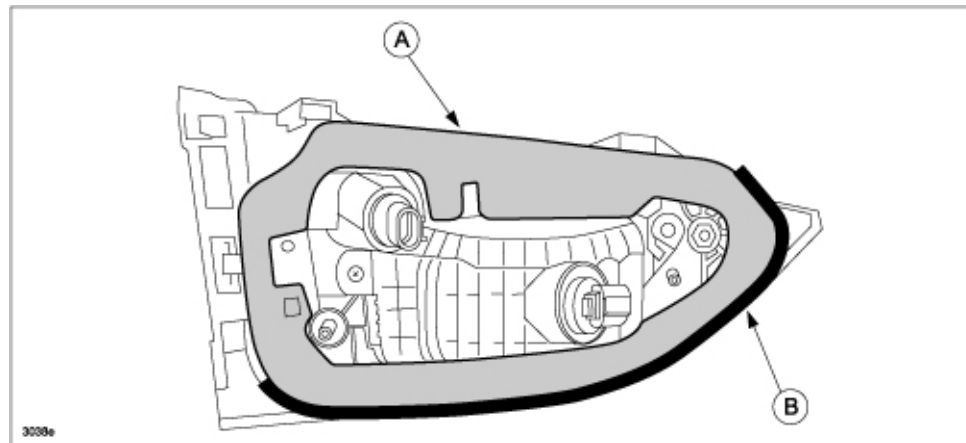

14. Attach the gasket (modified service part) to the trunk lid light.

NOTE:

- A double-sided adhesive tape is attached to both sides of the gasket. Peel off the release paper before attaching the gasket.
- Align the slit of the gasket and the position pin (B).
- Attach the gasket taking note of identification mark for Right (R) or Left (L) (A). Attach so that the gasket does not rest on the bolt flange (C).

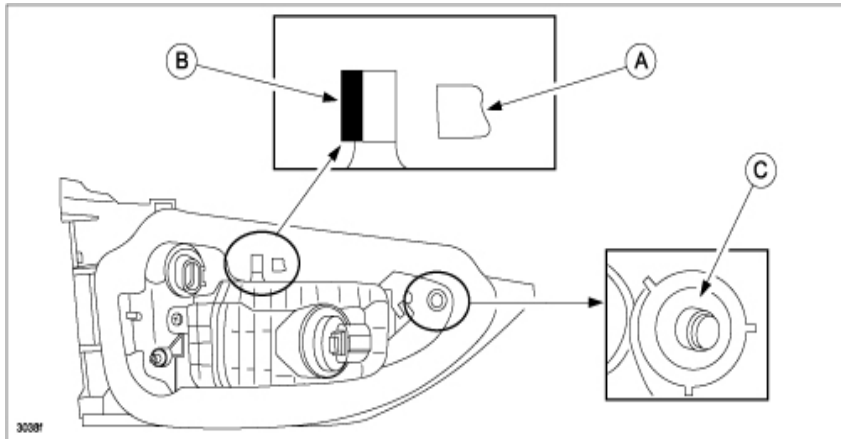

15. Peel off the release paper from the solid rubber and attach it to the trunk lid light between “a” and “b”.

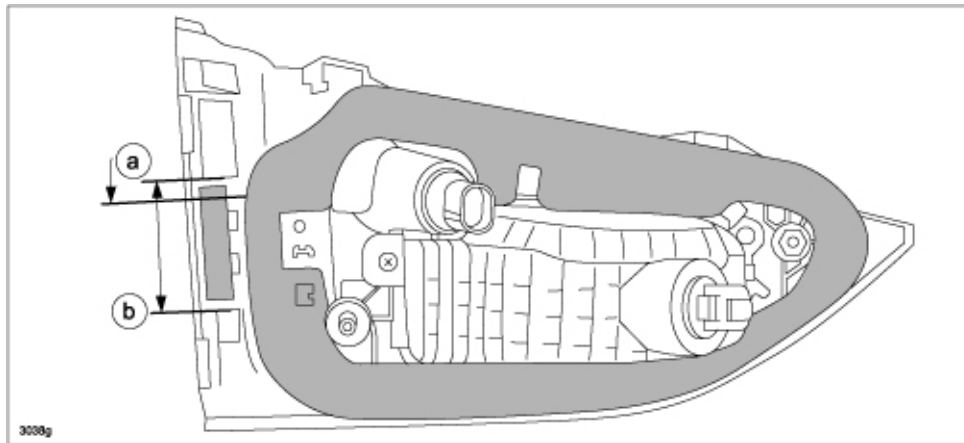

16. Peel off the release paper (at body panel side) from the gasket and install the trunk lid light to the vehicle.
Refer to MS3 online or Workshop Manual section 09-18 (TRUNK LID LIGHT REMOVAL/INSTALLATION).

17. Verify repair.

PART(S) INFORMATION

Case 1: When water drop stains can be removed by rinsing. The original trunk lid light is re-used.

Part Number	Description	Qty.
GHK1-51-3H8A	Gasket RH	1
GHK1-51-3J8A	Gasket LH	1
GHK1-51-3H9	Solid Rubber	1 or 2

Case 2: When water drop stains can NOT be removed by rinsing and a new trunk lid light is installed.

Part Number	Description	Qty.	Note
GHK1-51-3F0D	Trunk Lid Light RH	1	The modified gasket and the solid rubber are included
GHK1-51-3G0D	Trunk Lid Light LH	1	

WARRANTY INFORMATION

NOTE:

- This warranty information applies only to verified customer complaints on vehicles eligible for warranty repair.
- This repair will be covered under Mazda's New Vehicle Limited Warranty term.
- Additional diagnostic time cannot be claimed for this repair.

Case 1: When water drop stains can be removed by rinsing.

Warranty Type	A
Symptom Code	79
Damage Code	9F
Part Number Main Cause	GHK1-51-3H8A (RH) or GHK1-51-3J8A (LH)
Quantity	1
Operation Number / Labor Hours:	XXK7GARX / 0.6 Hrs. (One side) XXK7GBRX / 0.7 Hrs. (Both sides)
(Labor includes rinsing and re-installing original trunk lid light with modified gasket and solid rubber).	

Case 2: When water drop stains can NOT be removed by rinsing.

Warranty Type	A
Symptom Code	79
Damage Code	9F
Part Number Main Cause	GHK1-51-3H8A (RH) or GHK1-51-3J8A (LH)
Quantity	0
Operation Number / Labor Hours:	XXK7GDRX / 0.5 Hrs. (One side) XXK7GERX / 0.6 Hrs. (Both sides)
(Labor includes rinsing and installing new modified trunk lid light with modified gasket and solid rubber).	