

December 4, 2015

02870 Version 1

Wind Noise from the Driver's or Front Passenger's Window

AFFECTED VEHICLES

Year	Model	Trim	VIN Range
2015	Accord	4-Door	ALL
2016	Accord	4-Door L4	1HGCR2...GA000001 to 1HGCR2...GA057090
		4-Door V6	1HGCR3...GA000001 to 1HGCR3...GA009609

SYMPTOM

There is a noticeable wind noise at ear level from either the driver's or the front passenger's window.

POSSIBLE CAUSE

The wind noise is caused by a gap between the run channel and inner sash.

CORRECTIVE ACTION

Test-drive the vehicle to determine the location(s) of the wind noise. If the noise is heard at ear level from either the driver's or front passenger's window or along the B-pillar, tape it off and see if the noise goes away. If the noise goes away, this bulletin applies. If the noise is still heard, the bulletin does not apply. Troubleshoot and repair as needed. Based on your results, apply EPT sealer to the run channel groove.

REQUIRED MATERIALS

Part Name	Part Number	Quantity
EPT Sealer (One roll repairs about 165 vehicles.)	06990-SA5-000	1
Adhesion Promoter Kit (One packet repairs one vehicle.)	08F20-S9A-10003	1
3M Adhesion Promoter #06396 (Use if 08F20-S9A-10003 is not available. One box fixes 10 vehicles.)	Commercially available	1
Rubbing Alcohol (degreaser)	Commercially available	1

CUSTOMER INFORMATION: The information in this bulletin is intended for use only by skilled technicians who have the proper tools, equipment, and training to correctly and safely maintain your vehicle. These procedures should not be attempted by "do-it-yourselfers," and you should not assume this bulletin applies to your vehicle, or that your vehicle has the condition described. To determine whether this information applies, contact an authorized Honda automobile dealer.

WARRANTY CLAIM INFORMATION

For one side – use the following warranty information.

Operation Number	Description	Flat Rate Time	Template ID	Defect Code	Symptom Code	Failed Part Number
8150B3	Clean and apply EPT sealer on the left or right side window. (Includes test drive.)	0.4 hr	15-053A	07408	05604	72430-T2F-A01

For both sides – use the following warranty information.

Operation Number	Description	Flat Rate Time	Template ID	Defect Code	Symptom Code	Failed Part Number
8150B3	Clean and apply EPT sealer on the left or right side window. (Includes test drive.)	0.4 hr	15-053B	07408	05604	72430-T2F-A01
A	For the opposite side - add	0.4 hr				

Skill Level: Repair Technician

INSPECTION

Check the vehicle to determine the location(s) of the wind noise.

- If the wind noise is heard at ear level from either the driver's or front passenger's windows or along the B-pillar, tape it off and see if the noise goes away, If the noise goes away, go to REPAIR PROCEDURE.
- If the wind noise is heard elsewhere, this service bulletin does not apply. Continue normal troubleshooting procedures.

REPAIR PROCEDURE

NOTE: Repair only the affected side.

Apply EPT sealer to the run channel groove.

1. Remove the run channel from the upper part of the door frame.
2. Remove the run channel from the top corner of the B-pillar to B Line.

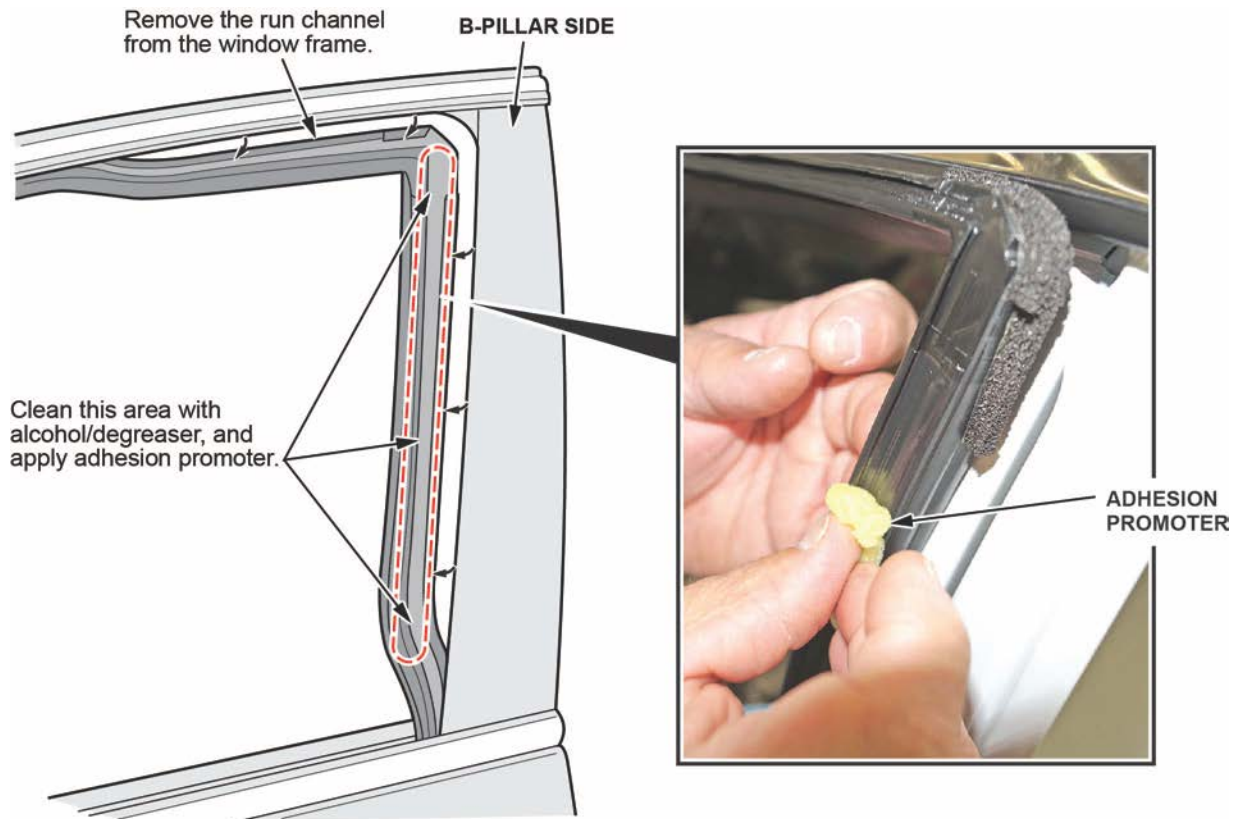

3. Clean the run channel groove along the B-pillar with rubbing alcohol.
4. Apply primer (3M Adhesion Promoter 4298UV) to the run channel groove along the B-pillar.

5. Cut a strip of EPT sealer that measures 3 mm x 400 mm x 3 mm and attach it to the groove of the run channel. Start at the top corner and install the strip down the run channel. Center the strip around the hash marks on the run channel.

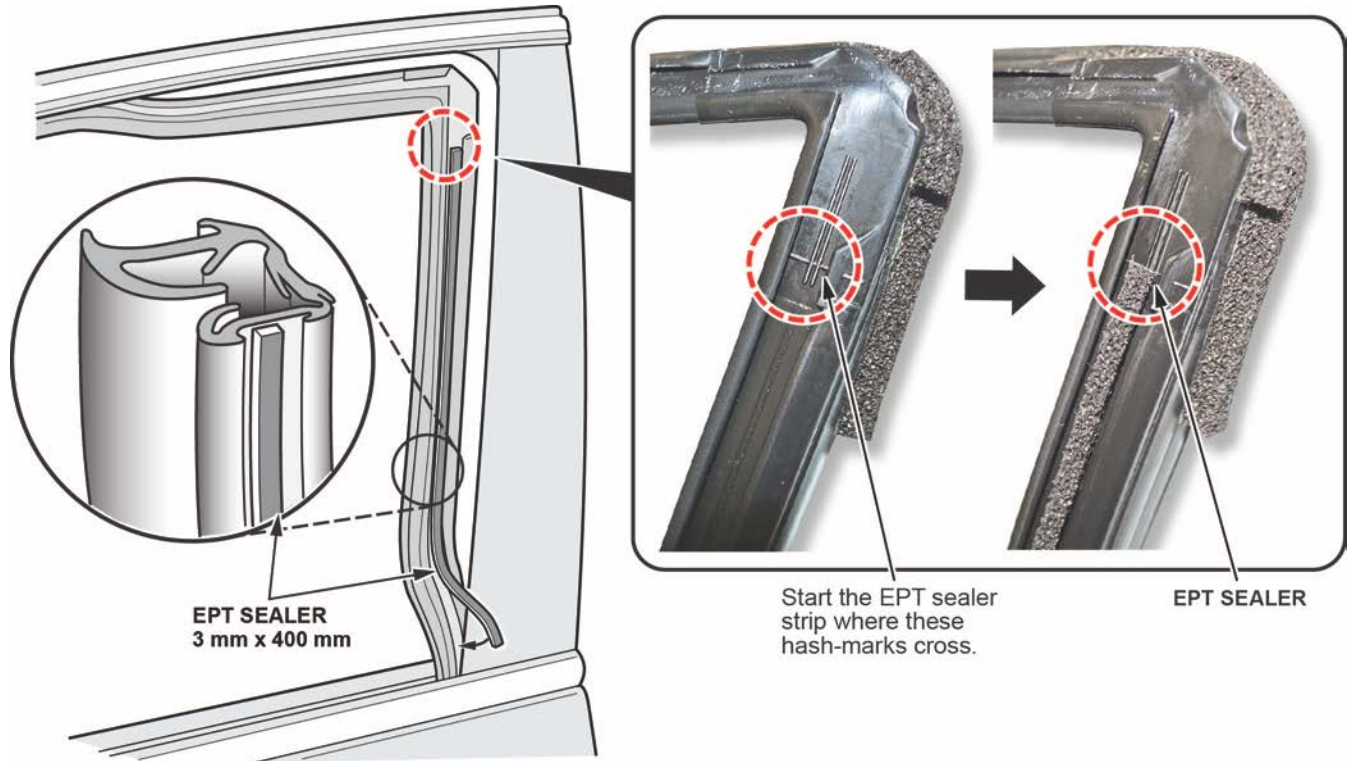

- Install the run channel by attaching at the Y-corner.
- Install the run channel down the B-pillar by attaching the outside edge first, then attaching the inside edge.
- Install the run channel along the top of the door frame.

NOTE: The corner may require some force to be properly installed.

6. Push the run channel up against the sash trim to set the EPT sealer, then check for any gaps or visible sealer.
7. Check that the wind noise is gone.

END