

Subject: POPPING AND/OR SQUEAKING NOISE FROM FRONT SHOCK ABSORBER	Bulletin No: 02-004/15
	Last Issued: 04/24/2015

APPLICABLE MODEL(S)/VINS

2014-2015 Mazda3 vehicles (Japan built) with VINs starting with JM1

2014-2015 Mazda3 vehicles (Mexico built) with VINs starting with 3MZ

DESCRIPTION

Some vehicles may exhibit one or both of the following noises from the front shock absorber.

- A popping noise when passing over speed bumps.
- A squeaking noise when turning the steering wheel at a vehicle standstill.

To correct the problem, the shape of the bump stopper has been modified and a protector has been installed onto the coil spring.

Customers having this concern should have their vehicle repaired using the following repair procedure.

REPAIR PROCEDURE

1. Verify the customer concern of noise coming from the upper part of the shock absorber when turning the steering wheel and/or driving over bumps.
2. Replace the bump stopper with the modified one according to MS3 online instructions or the Workshop Manual (section 02-13 FRONT SHOCK ABSORBER AND COIL SPRING DISASSEMBLY/ASSEMBLY).

NOTE: Before removing the mounting rubber, mark its original position so it can be re-installed later to the same position.

CAUTION: It is not necessary to adjust the front wheel alignment because the front shock absorber and mounting rubber are not being replaced. However, make sure to install the mounting rubber to the original position.

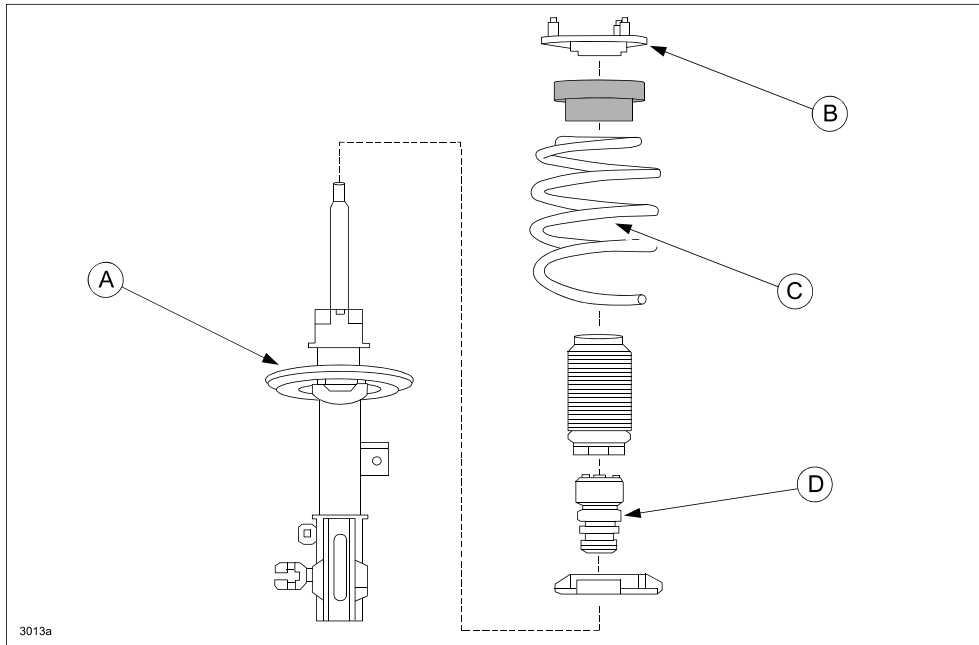

3013a

A	Front Shock Absorber	C	Coil Spring
B	Mounting Rubber	D	Bump Stopper

3. Install the protector onto the coil spring.
 - a. Degrease 1.5 turns of the spring from the top.
 - b. Cut a thin strip of paper to 138 mm in length (or use a cloth type measuring tape).
 - c. Place the strip of paper (or cloth measuring tape) along the inner side of the coil spring starting at point (A).
 - d. Mark the spot on the spring where (B) is. (B) is the starting point for the protector installation.

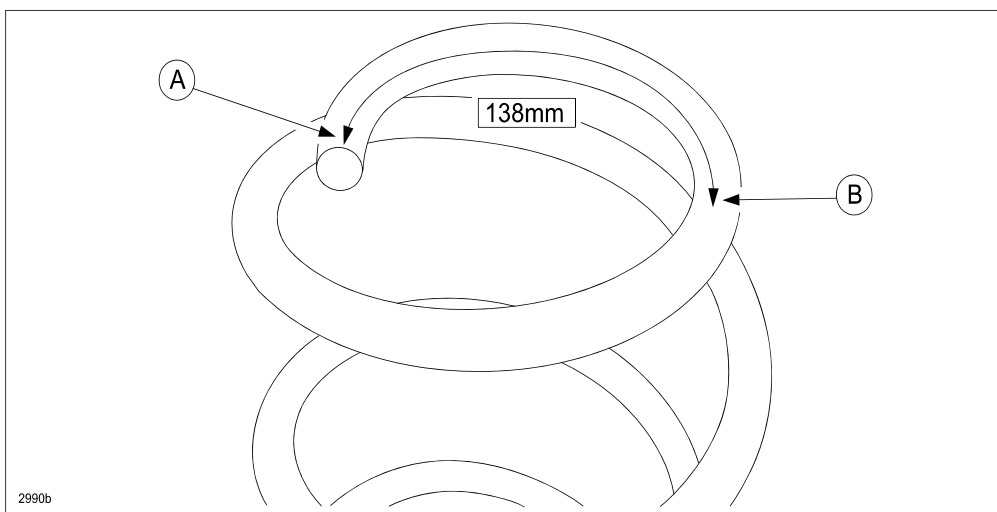

2990b

- e. Install the protector (A) onto the coil spring aligning the end (slant cut side) with the marking at spot (B).

NOTE: Install the protector so the gap (C) is evenly aligned around the outer edge of the coil spring.

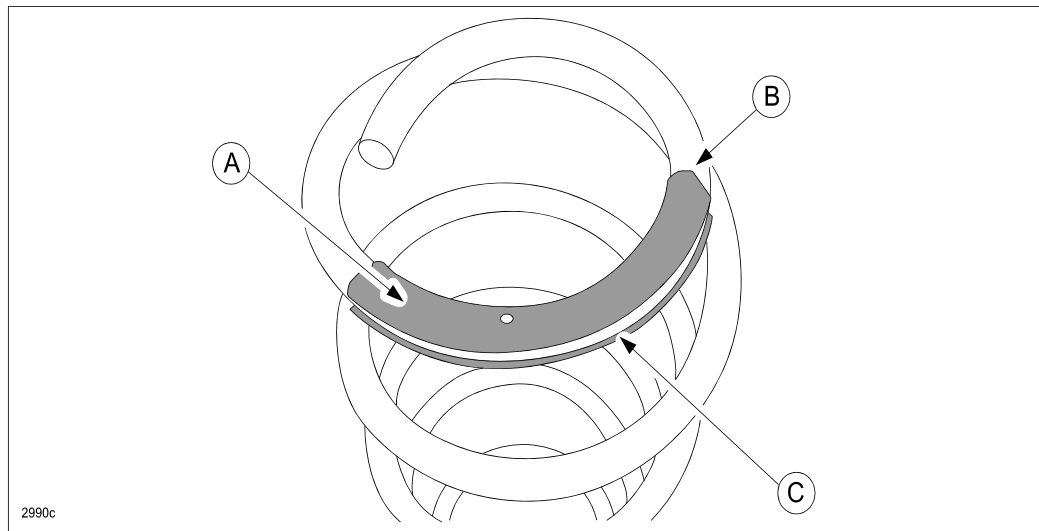

- f. The inner side of the protector contains adhesive glue. After installing the protector onto the spring, press the inner side to firmly adhere it to the spring.

PART(S) INFORMATION

Part Number	Description	Qty.	Notes
B4YA-34-111	Stopper, Bump	1 / one side	Refer to the EPC for the correct part number
B4YG-34-111	Stopper, Bump	1 / one side	
KDY5-34-081	Protector	1 / one side	All models
9YB0-41-237	Piston Rod Nut	1 / one side	All models

WARRANTY INFORMATION

NOTE:

- This warranty information applies only to verified customer complaints on vehicles eligible for warranty repair.
- This repair will be covered under Mazda's New Vehicle Limited Warranty term.
- Additional diagnostic time cannot be claimed for this repair.

	One Side	Both Sides
Warranty Type	A	A
Symptom Code	82	82
Damage Code	97	97
Part Number Main Cause	B4YA-34-111 or B4YG-34-111	B4YA-34-111 or B4YG-34-111
Quantity	1	2
Operation Number / Labor Hours	XXKCKARX / 0.5 Hrs.	XXKCKBRX / 0.9 Hrs.