

September 16, 2015

49031-02409 Version 3

MIL Comes ON with DTC P2646/P2651 or P2647/P2652

(Supersedes 13-021, dated February 28, 2013, to revise the information highlighted in yellow)

AFFECTED VEHICLES

Year	Model	Trim	VIN Range
2003–12	Accord L4	ALL	ALL
2012–13	Civic	ALL except Si and Hybrid	ALL
2002–05	Civic Si	ALL	ALL
2002–09	CR-V	ALL	ALL
2011	CR-Z	ALL	ALL
2003–11	Element	ALL	ALL
2007–11	Fit	ALL	ALL

REVISION SUMMARY

Under REPAIR PROCEDURE, illustrations in step 2 specific to 2008–12 Accord PZEV were added along with additional FRT.

SYMPTOM

The MIL comes on with one of these DTCs:

- P2646/P2651 (rocker arm oil pressure switch circuit low voltage).
- P2647/P2652 (rocker arm oil pressure switch circuit high voltage).

NOTE: The symptom may be intermittent and you may not be able to duplicate it after clearing the DTC.

POSSIBLE CAUSES

The rocker arm oil pressure switch may fail intermittently.

CORRECTIVE ACTION

Replace the rocker arm oil pressure switch.

PARTS INFORMATION

Part Name	Part Number	Quantity
Rocker Arm Oil Pressure Switch	37250-PNE-G01	1
O-ring (13 mm x 1.5 mm)	91319-PAA-A01	1

CUSTOMER INFORMATION: The information in this bulletin is intended for use only by skilled technicians who have the proper tools, equipment, and training to correctly and safely maintain your vehicle. These procedures should not be attempted by "do-it-yourselfers," and you should not assume this bulletin applies to your vehicle, or that your vehicle has the condition described. To determine whether this information applies, contact an authorized Honda automobile dealer.

WARRANTY CLAIM INFORMATION

The normal warranty applies.

Model	Operation Number	Description	Flat Rate Time	Failed Part Number
2003–07 Accord L4	110165	Replace the rocker arm oil pressure switch.	0.3 hr	37250-PNE-G01
2008–12 Accord L4 Except PZEV			0.5 hr	
2008–12 Accord L4 PZEV only			0.6 hr	
2002–05 Civic Si			0.3 hr	
2002–09 CR-V				
2011 CR-Z				
2003–11 Element				
2007–11 Fit				
2012–13 Civic				

Defect Code: 03214

Symptom Code: 03272

Skill Level: Repair Technician

REPAIR PROCEDURE

1. Remove the power steering high pressure hose bracket mounted on the valve cover.

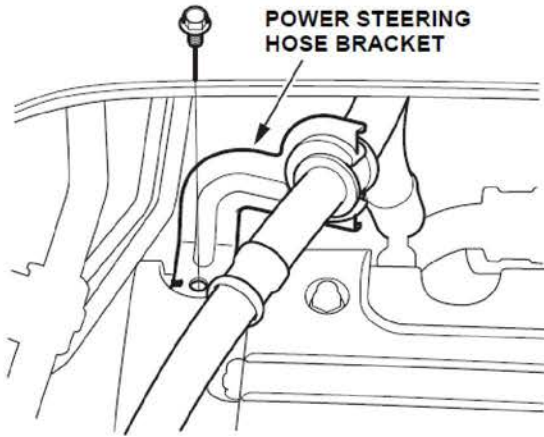

2. *PZEV*: Remove the wire harness and the brackets.
3. Remove the rocker arm oil pressure switch and the O-ring:

2008–2012 Accord

ROCKER ARM OIL PRESSURE SWITCH
22 N·m (16 ft-lb)

O-RING
Replace.

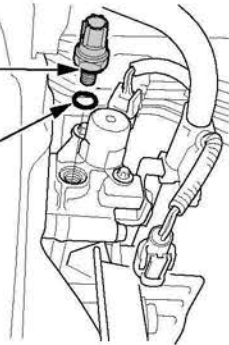

2012–2013 Civic

ROCKER ARM OIL PRESSURE SWITCH
22 N·m (16 ft-lb)

O-RING
Replace.

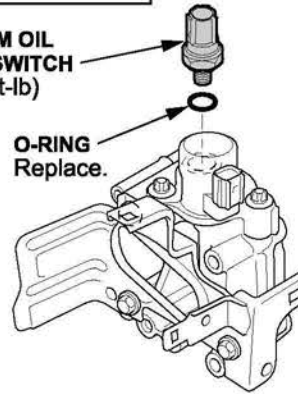

**2003–2012 Accord L4
2002–2005 Civic Si
2002–2009 CR-V
2003–2011 Element**

ROCKER ARM OIL PRESSURE SWITCH
22 N·m (16 ft-lb)

O-RING
Replace.

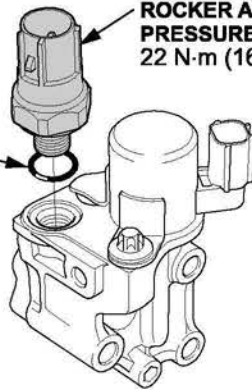

**2007–2012 Fit
2011–2012 CR-Z**

O-RING
Replace.

ROCKER ARM OIL PRESSURE SWITCH
22 N·m (16 ft-lb)

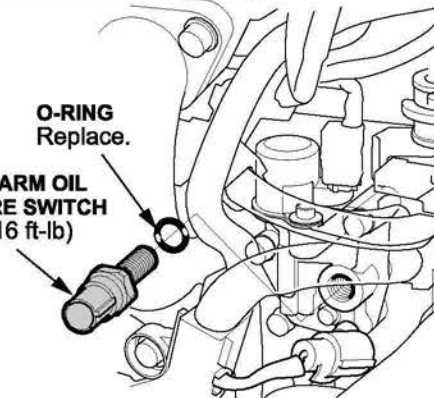

2008–2012 Accord PZEV

WIRE HARNESS

CONTROL VALVE ASSEMBLY

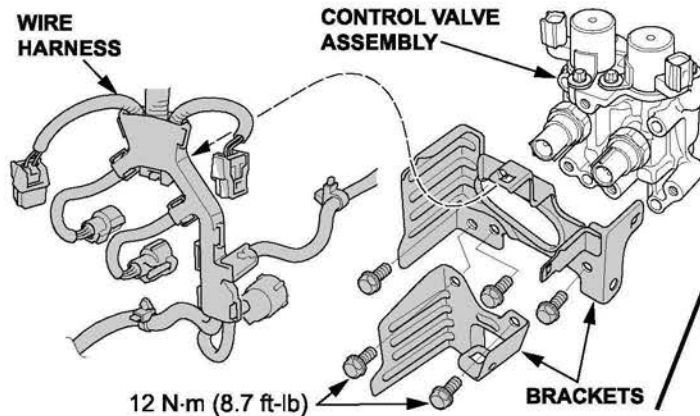

12 N·m (8.7 ft-lb)

BRACKETS

O-RING
Replace.

ROCKER ARM OIL PRESSURE SWITCH
22 N·m (16 ft-lb)

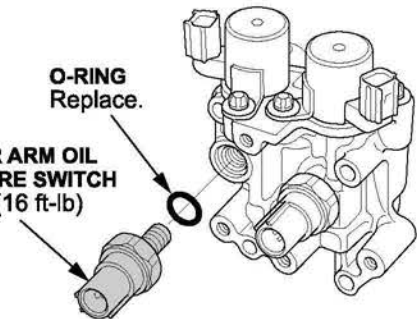

4. Install the new rocker arm oil pressure switch and the new O-ring. Torque the switch to **22 N·m (16 lbft)**.
5. *PZEV*: Install the brackets and torque the bolts to **12 N·m (8.7 lb-ft)**, then install the wire harness.
6. Reinstall the power steering high pressure hose bracket.
7. Clear the DTC(s) with the HDS.

NOTE: If the DTC returns, refer to the troubleshooting procedure for the DTC that is set.

END