



Technical Service Bulletin

SUBJECT: NON-REUSABLE PARTS INDICATION ADDED – SERVICE MANUAL REVISION			No: TSB-15-15-001
			DATE: January, 2015
			MODEL: See below
CIRCULATE TO:	<input type="checkbox"/> GENERAL MANAGER	<input checked="" type="checkbox"/> PARTS MANAGER	<input checked="" type="checkbox"/> TECHNICIAN
<input checked="" type="checkbox"/> SERVICE ADVISOR	<input checked="" type="checkbox"/> SERVICE MANAGER	<input checked="" type="checkbox"/> WARRANTY PROCESSOR	<input type="checkbox"/> SALES MANAGER

PURPOSE

This TSB adds the non-reusable parts indication (**N**) missing in the service manual for certain exhaust fasteners.

AFFECTED VEHICLES

2008–2015 Lancer
 2009–2015 Lancer Sportback
 2008–2015 Lancer Evolution
 2011–2015 Outlander Sport/RVR
 2008–2015 Outlander

AFFECTED SERVICE MANUALS

2008–2010 Lancer, Group 15 Intake and Exhaust —>
 Exhaust Pipe and Main Muffler <2.0L Engine Non-turbo, 2.4L Engine> Removal and Installation
 Exhaust Pipe, Main Muffler and Catalytic Converter <2.0L Engine Turbo> Removal and Installation

2009–2010 Lancer Sportback, Group 15 Intake and Exhaust —>
 Exhaust Pipe, Main Muffler and Catalytic Converter <2.0L Engine>
 Exhaust Pipe and Main Muffler <2.4L Engine>

2011–2015 Lancer/Lancer Sportback, Group 15 Intake and Exhaust —>
 Exhaust Pipe and Main Muffler <2.0L Engine Non-turbo, 2.4L Engine> Removal and Installation
 Exhaust Pipe, Main Muffler and Catalytic Converter <2.0L Engine Turbo> Removal and Installation

2008–2015 Lancer Evolution, Group 15 Intake and Exhaust —> Exhaust Pipe and Main Muffler —>
 Removal and Installation

2011–2015 Outlander Sport/RVR, Group 15 Intake and Exhaust —> Exhaust Pipe and Main Muffler —>
 Removal and Installation

2008–2013 Outlander, Group 15 Intake and Exhaust —> Exhaust Pipe and Main Muffler —> Removal
 and Installation

2014–2015 Outlander, Group 15 Intake and Exhaust —> Exhaust Pipe and Main Muffler —> Removal
 and Installation

Please make the changes indicated on pages 2 and 3 to the
2008-2010 Lancer/Service Manual,
2009-2010 Lancer Sportback Service Manual,
2011-2015 Lancer/Lancer Sportback Service Manual,
Group 15 Intake and Exhaust —> Exhaust Pipe and Main Muffler Removal and Installation <2.0L Engine
Non-turbo, 2.4L Engine>

Lancer/Lancer Sportback

<2.0L ENGINE Non-turbo, 2.4L ENGINE>

<Except for California>

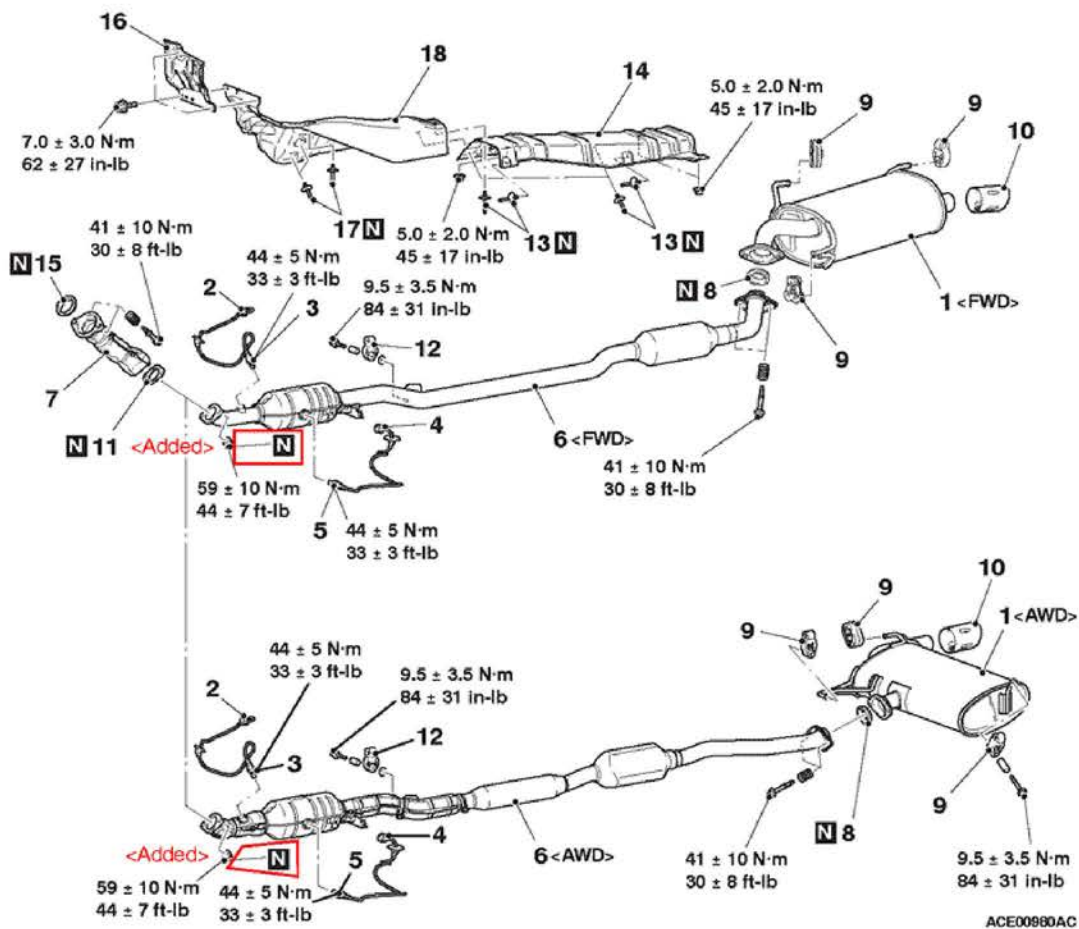

Lancer/Lancer Sportback

<For California>

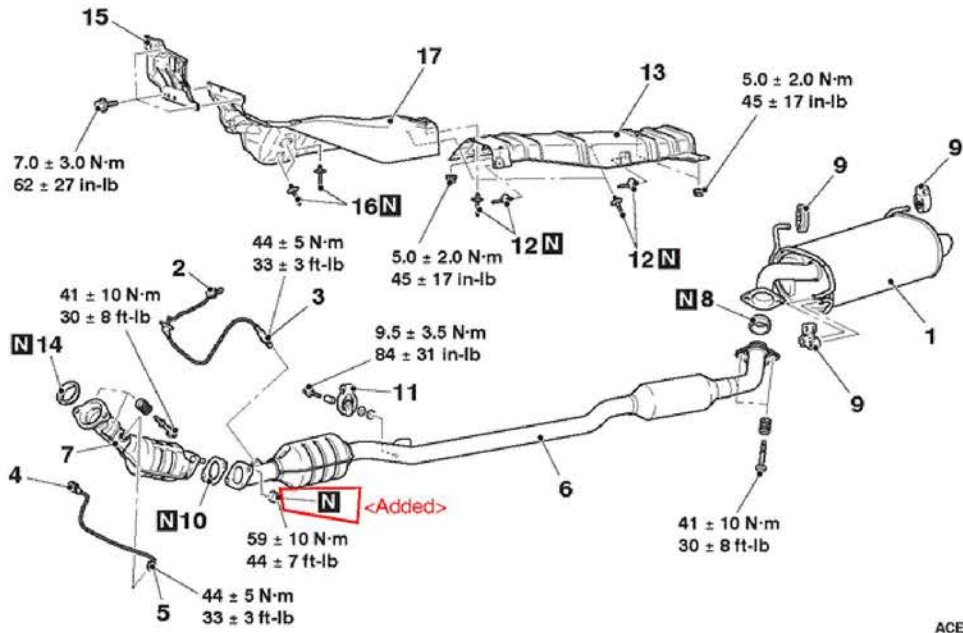

ACE01074AC

Please make the indicated changes to the
2008-2010 Lancer/Service Manual,
2009-2010 Lancer Sportback Service Manual,
2011-2015 Lancer/Lancer Sportback Service Manual,
Group 15 Intake and Exhaust → Exhaust Pipe and Main Muffler Removal and Installation <2.0L Engine
Turbo>

Lancer/Lancer Sportback

<2.0L ENGINE Turbo>

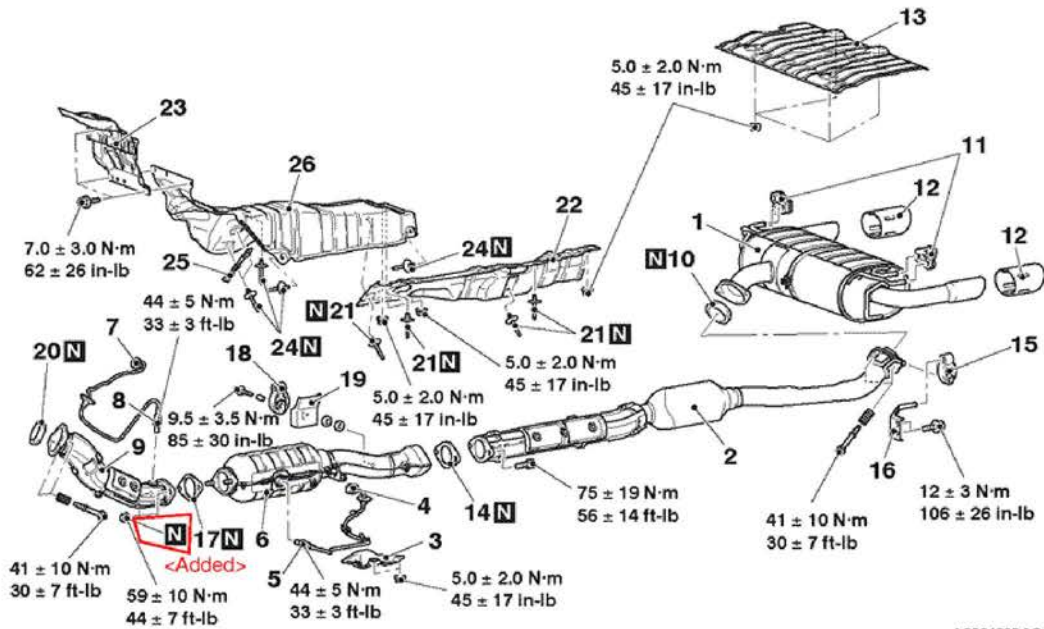

Please make the indicated changes to the 2008–2015 Lancer Evolution Service Manual , Group 15 Intake and Exhaust → Exhaust Pipe and Main Muffler → Removal and Installation

Lancer Evolution

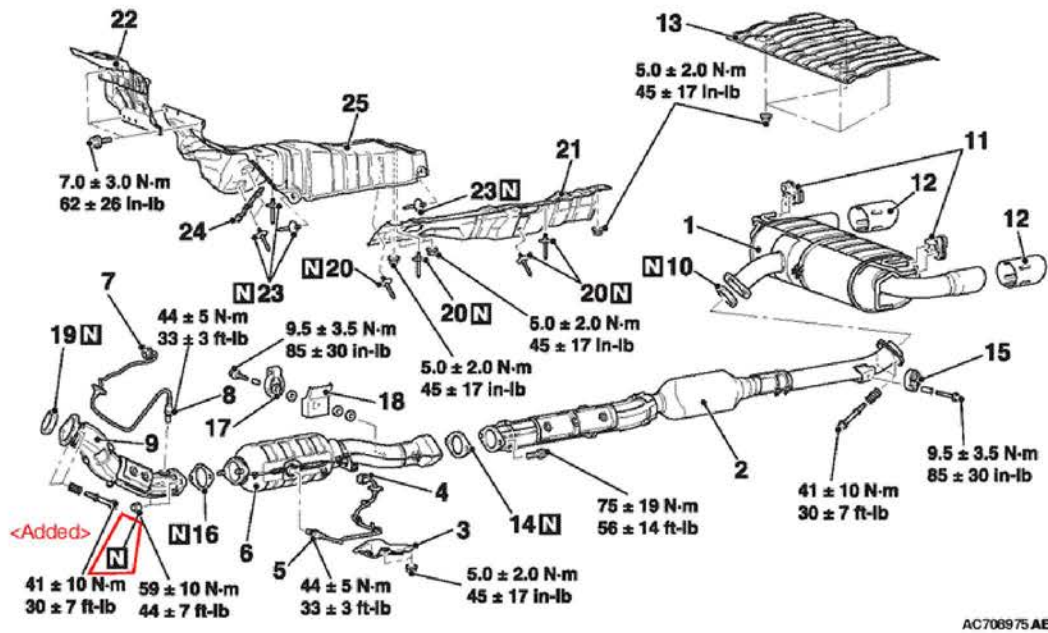

Please make the indicated changes to the 2011-2015 Outlander Sport/RVR Service Manual, Group 15
Intake and Exhaust —> Exhaust Pipe and Main Muffler —> Removal and Installation

Outlander Sport/RVR

<FWD>

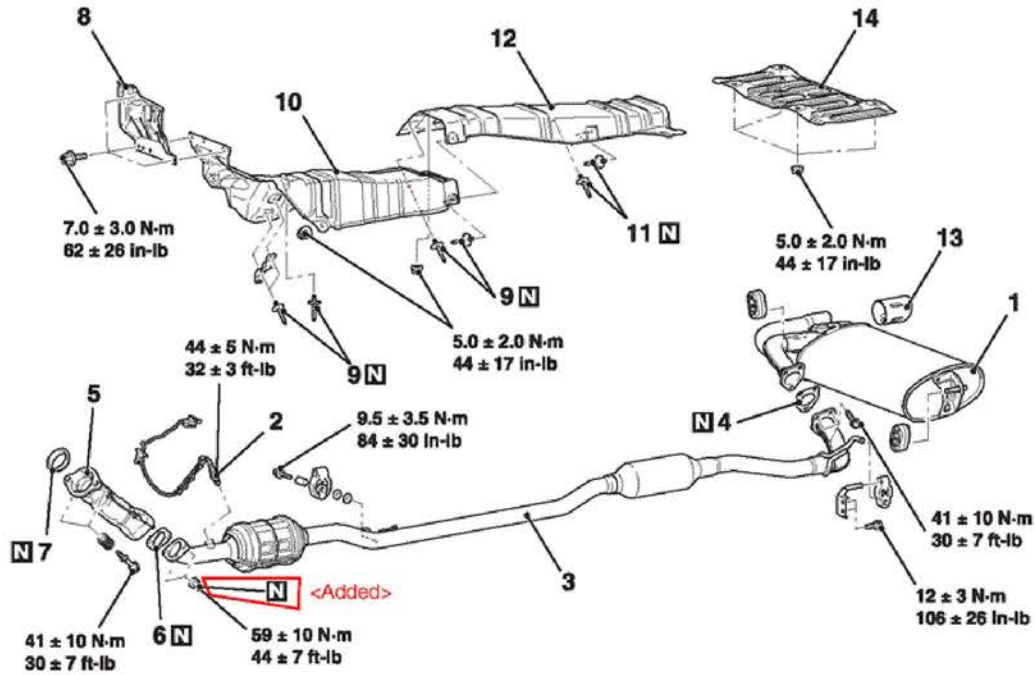

Please make the indicated changes to the 2011-2015 Outlander Sport/RVR Service Manual, Group 15 Intake and Exhaust —> Exhaust Pipe and Main Muffler —> Removal and Installation

Outlander Sport/RVR

<AWD>

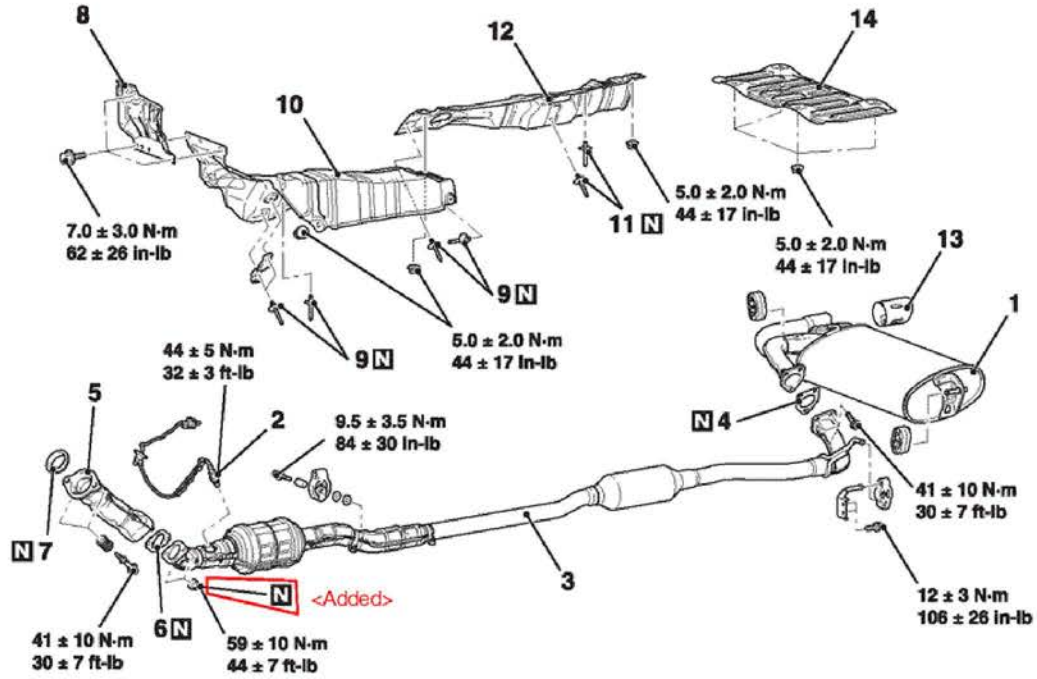

ACD02648 AD

Please make the changes indicated on pages 8 and 9 to the 2008-2013 Outlander Service Manual, Group 15 Intake and Exhaust → Exhaust Pipe and Main Muffler → Removal and Installation

Outlander
<2.4L ENGINE>

<FWD>

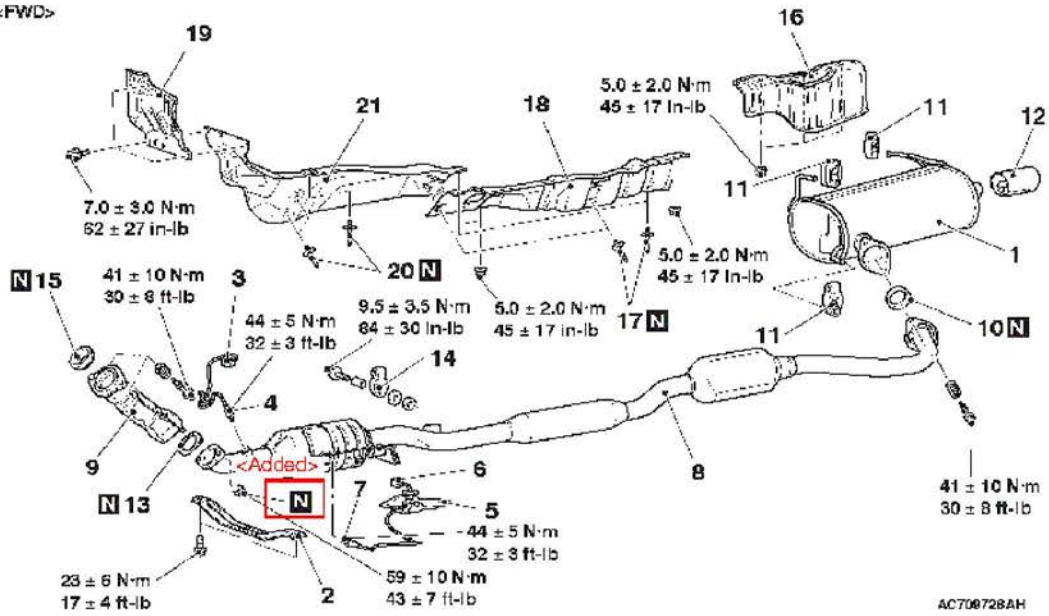

<AWD>

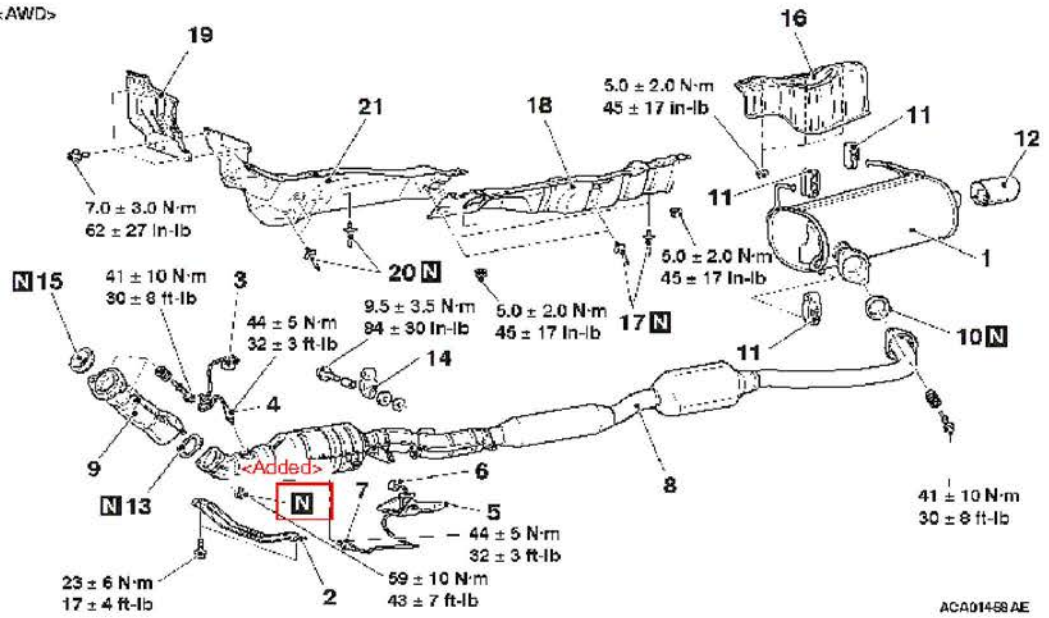

Outlander

<3.0L ENGINE>

<FWD>

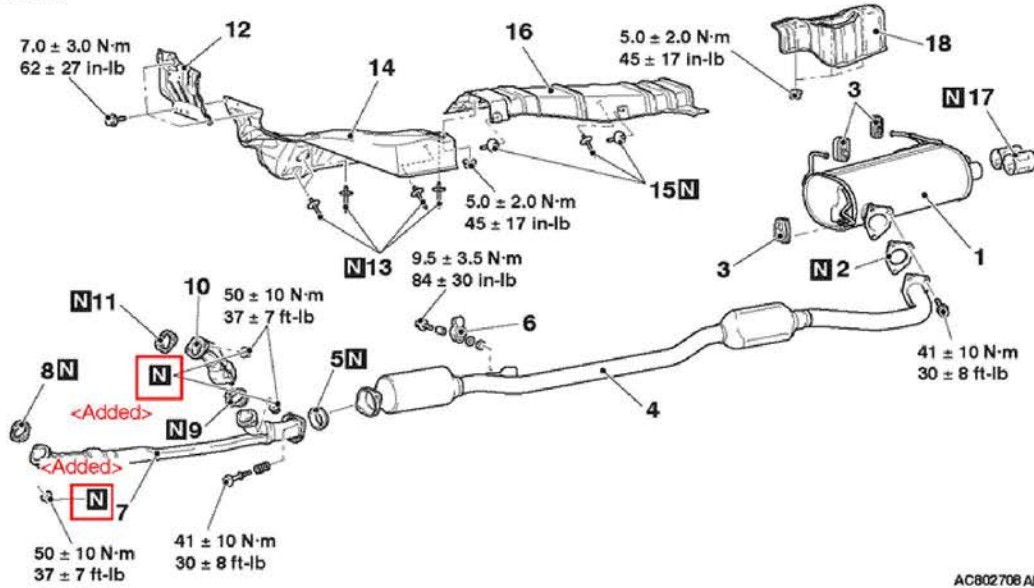

<AWD>

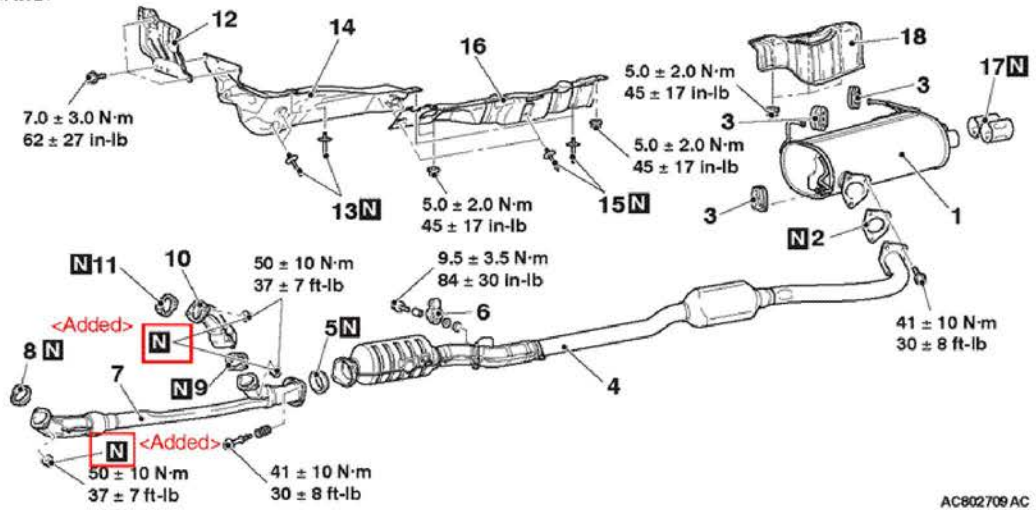

Please make the indicated changes to the 2014-2015 Outlander Service Manual, Group 15 Intake and Exhaust → Exhaust Pipe and Main Muffler → Removal and Installation

Outlander

<3.0 L ENGINE>

