

Tire Pressure Warning System Activation & Initialization

Service Category General

Section Pre-Delivery Service

Market USA

Lexus Supports
ASE Certification 

Applicability

YEAR(S)	MODEL(S)	ADDITIONAL INFORMATION
2016	LS460, LS600H	

Introduction

2016 model year LS 460 and LS 600h vehicles are equipped with a direct-type Tire Pressure Warning System (TPWS). Each tire (including the spare tire) has a tire pressure warning valve/sensor that measures tire pressure. The data is transmitted to the Tire Pressure Warning System antenna/receiver and then to the Tire Pressure Warning System ECU.

During Pre-Delivery Service (PDS), the tire pressure warning valves/sensors must be activated according to the procedure in this bulletin.

Warranty Information

OP CODE	DESCRIPTION	TIME	OFF	T1	T2
N/A	Not Applicable to Warranty	-	-	-	-

Required Tools & Equipment

REQUIRED EQUIPMENT	SUPPLIER	PART NUMBER	QTY
Techstream 2.0*	ADE	TS2UNIT	1
Techstream Lite		TSLITEPDLR01	

* Essential SST.

NOTE

- Only ONE of the Techstream units listed above is required.
- Software version 10.20.030 or later is required.
- Additional Techstream units may be ordered by calling Approved Dealer Equipment (ADE) at 1-800-368-6787.

Tire Pressure Warning System Activation & Initialization

Reference

- After cycling the ignition to the “IG-ON” mode, the Low Tire Pressure Warning Light will blink until all the tire pressure warning valves/sensors are activated.
- The Diagnostic Trouble Codes (DTCs) listed below may be stored in the TPWS ECU until the tire pressure warning valves/sensors are activated.
- The multi-information display will read “Check Tire Pressure System” until all tire pressure warning values/sensors are activated.
- The DTCs will automatically clear when the tire pressure warning valves/sensors are activated.

Figure 1

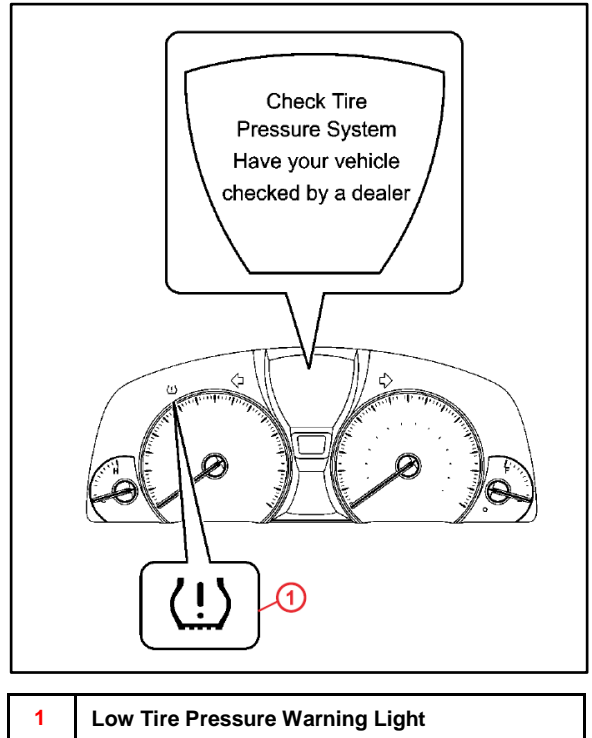

DTC ^{*1}	DTC ^{*2}	DTC
11	C2111	Transmitter ID1 Inactive
12	C2112	Transmitter ID2 Inactive
13	C2113	Transmitter ID3 Inactive
14	C2114	Transmitter ID4 Inactive
15	C2115	Transmitter ID5 Inactive

*1: Indicated by flashing of the Low Tire Pressure Warning Light.

*2: Indicated by Techstream.

Tire Pressure Warning System Activation & Initialization

Activation Procedure

1. Connect Techstream.
2. Cycle the ignition switch to the "IG-ON" mode and check that the Low Tire Pressure Warning Light blinks for 1 minute and then remains illuminated.

NOTE

"Check Tire Pressure System" is displayed on the multi-information display until all tire pressure warning valve/sensors are activated

3. Press or remove the valve core to reduce the tire inflation pressure rapidly by 6 psi (0.4 kgf/cm², 40 kPa), or more, within 30 seconds. If the tire inflation pressure is NOT reduced by 6 psi (0.4 kgf/cm², 40 kPa), or more, within 30 seconds, the tire pressure warning valves/sensors will NOT be activated.

NOTE

This operation is required for the system to be activated and MUST be performed for each tire (including the spare tire), one at a time.

Figure 2

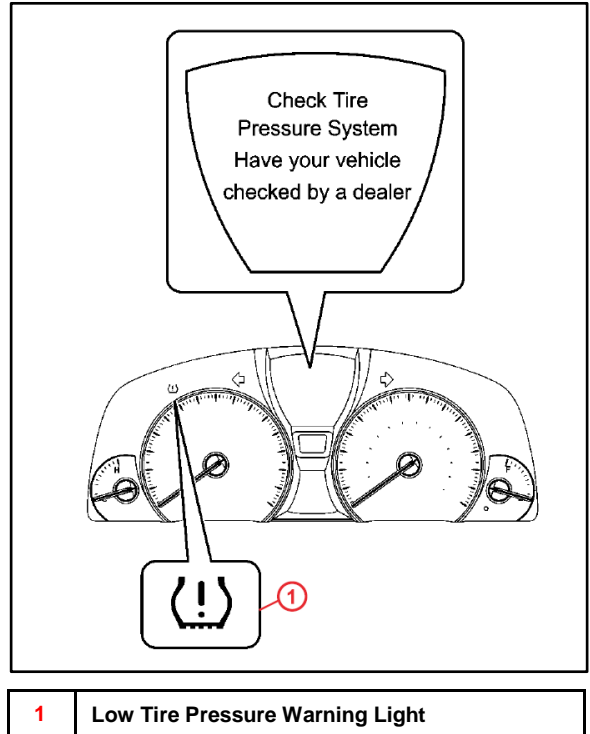
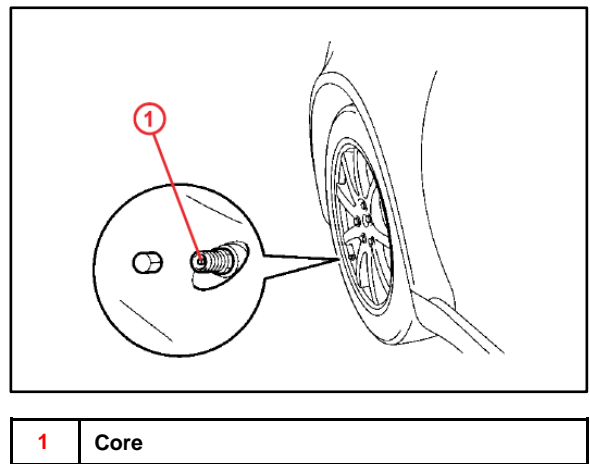

Figure 3



Tire Pressure Warning System Activation & Initialization

Activation Procedure (Continued)

4. Check that the Low Tire Pressure Warning Light goes OFF after all the tire pressure warning valves/sensors are activated.
5. Using Techstream, check for TPWS DTCs.
 - If NO DTCs are stored, go to step 6.
 - If DTCs C2111 – C2115 are stored, repeat step 3.
 - If any other DTCs are stored, refer to the Repair Manual.
6. Press the “DISP” switch on the steering wheel and check that the tire pressures are displayed on the multi-information display.

NOTE

- The tire pressure display is **NOT** shown until all tire pressure warning valves/sensors are activated.
- If “Check Tire Pressure System” or “CHECKING” (which means the tire pressures are being measured) is displayed, repeat step 3. If step 3 is performed and the tire pressures are still **NOT** displayed, turn the tires 90 to 270 degrees.
- If the above steps are performed and the multi-information display does **NOT** show the tire pressures, refer to the Repair Manual.

Figure 4

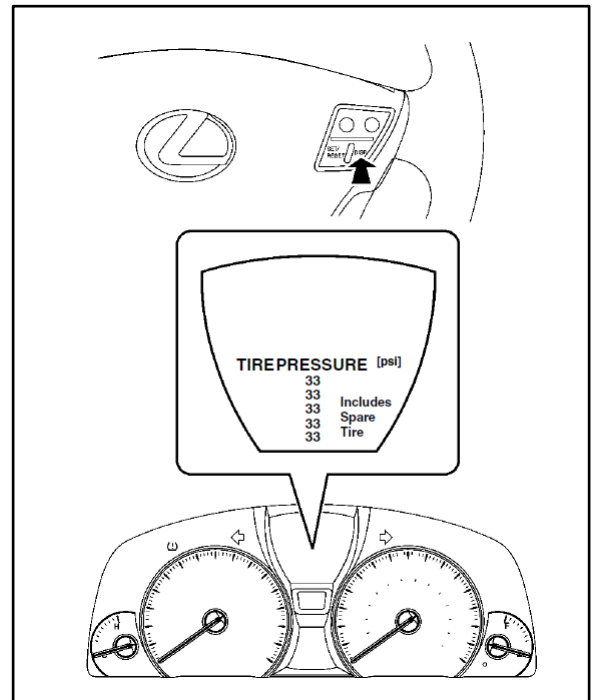

Tire Pressure Warning System Activation & Initialization

Initialization Procedure

1. Adjust all tires (including the spare tire) to the standard tire inflation pressure, as indicated on the Tire and Loading Information Label located in the vehicle.

NOTE

- To adjust tire pressure correctly when outside temperature is significantly colder than shop temperature, perform a Health Check using Techstream and select the “Compensation Tire Pressure” checkbox. Compensation pressures will be displayed on the Health Check results screen.
- Adjust the tire pressure when the tires are cold.

Figure 5

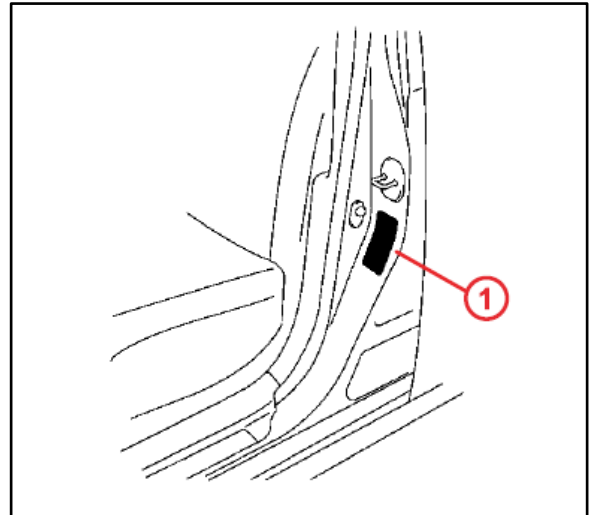

1 Tire and Loading Information Label

2. Cycle the ignition switch to the “IG-ON” mode and then push and hold the Tire Pressure Warning “SET” switch for 3 seconds until the Low Tire Pressure Warning Light blinks 3 times and then turns OFF to set the tire pressure initialization.

NOTE

- Make sure that the “Tire Pressure Reset Proceeding” appears on the multi-information display. After a few seconds, the display changes to “CHECKING” (which means the tire pressures are being measured).
- It is necessary for the ignition to be in the “IG-ON” mode AT LEAST 5 minutes for initialization to complete correctly.

Figure 6

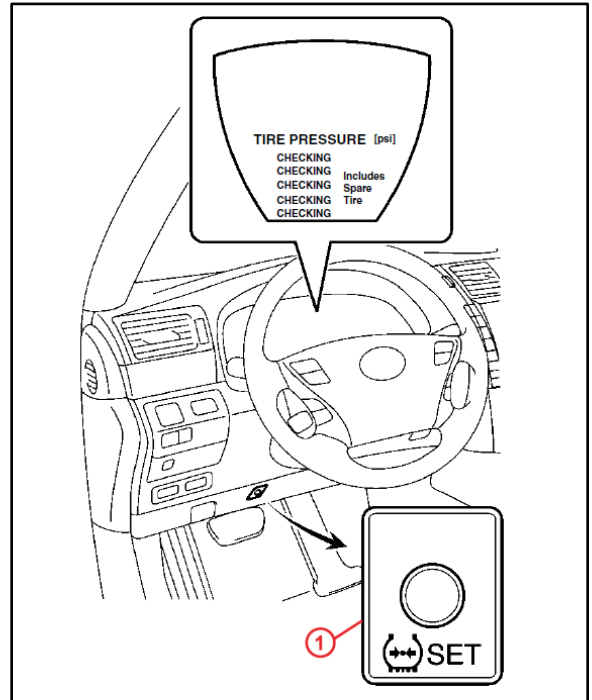

1 Tire Pressure Warning “SET” Switch

Tire Pressure Warning System Activation & Initialization

Initialization Procedure (Continued)

3. Cycle the ignition switch to “OFF” and then to “IG-ON” mode.

4. Check that the tire pressures for all 5 tires are displayed on the multi-information display. If the tire pressure values are NOT displayed on the multi-information display, the initialization is NOT complete. Repeat steps 2 – 4.

NOTE

- Check that the tire pressure adjusted in step 1 is displayed).
- Initialization will be completed if signals are received from all 5 tires. It takes 2 to 3 minutes to display the tire pressure data.

Figure 7

