

Front License Plate & Mounting Bracket Installation

Service Category General

Section Pre-Delivery Service

Market USA

Lexus Supports
ASE Certification 

Applicability

YEAR(S)	MODEL(S)	ADDITIONAL INFORMATION
2016	RX350, RX450H	

Introduction

The front license plate mounting bracket and 2 self-tapping screws for the 2016 model year RX 350 and RX 450h are stored in the glove compartment of the vehicle. Install the license plate and mounting bracket during Pre-Delivery Service (PDS).

Warranty Information

OP CODE	DESCRIPTION	TIME	OFFP	T1	T2
N/A	Not Applicable to Warranty	–	–	–	–

Front License Plate & Mounting Bracket Installation

Installation Procedure

- Align holes "A" of the mounting bracket with the dimples on the front bumper cover. Mark the location of holes "B" on the front bumper cover.

NOTE

- Holes "A" are used to install the mounting bracket to the bumper cover.
- Holes "B" are used to install the front license plate to the mounting bracket.

Figure 1.

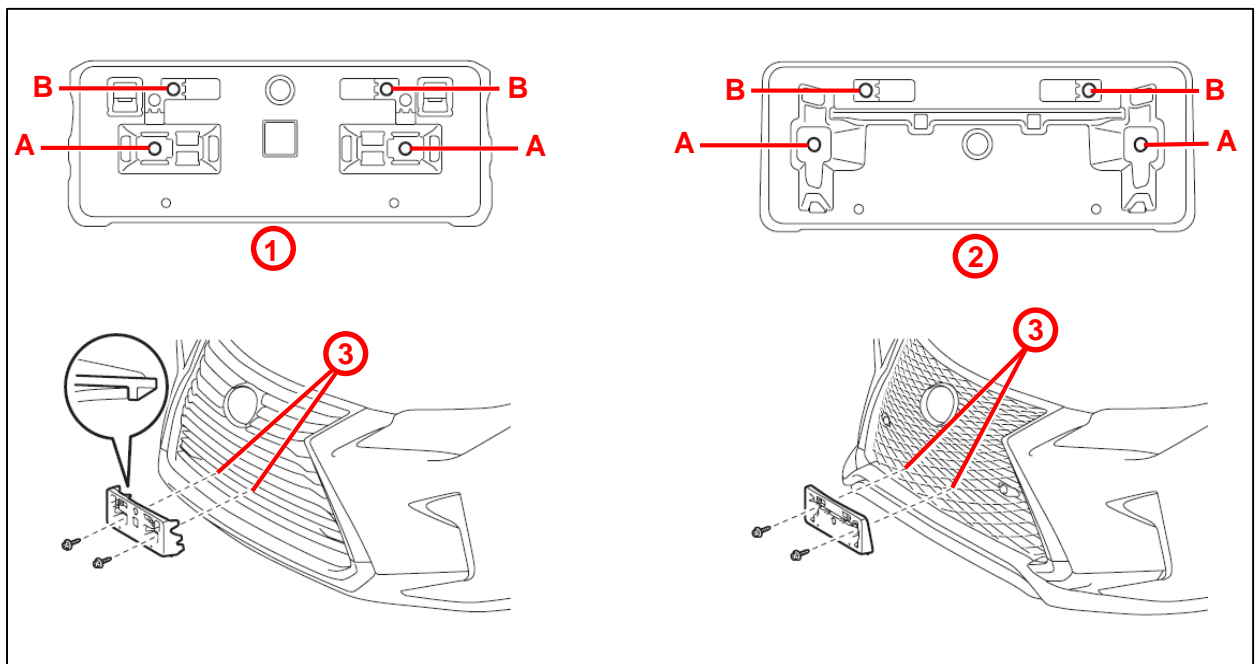

1	Mounting Bracket for Bar Type Radiator Grille
2	Mounting Bracket for Mesh Type Radiator Grille

3	Dimples
4	Self-tapping Screws

- Screw the two self-tapping screws directly into the dimples to install the front license plate mounting bracket.

NOTE

- Do NOT pre-drill holes in the dimples.
- Do NOT over-tighten the self-tapping screws

Front License Plate & Mounting Bracket Installation

Installation Procedure (Continued)

3. Install the front license plate using 2 non-corroding bolts with the following dimensions:

Nominal Length: 15.0 mm (0.59 in.)

Diameter: 6.0 mm (0.24 in.)

Figure 2.

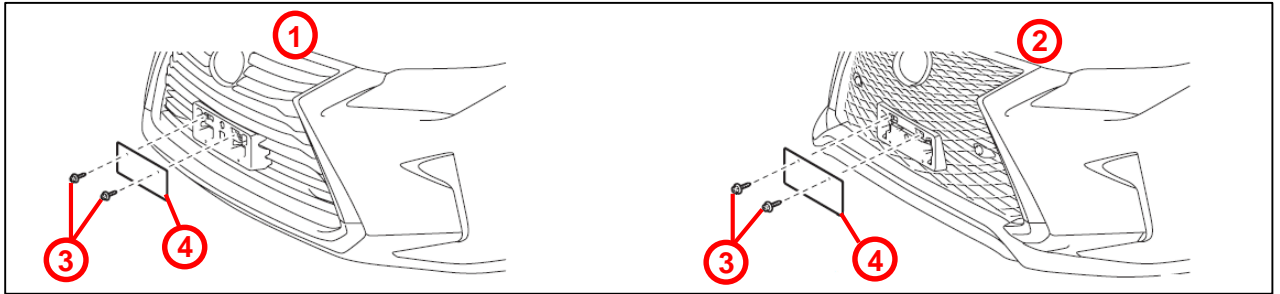

1	Vehicles Equipped with Bar Type Radiator Grille
2	Vehicles Equipped with Mesh Type Radiator Grille

3	Bolts
4	Front License Plate

Figure 3.

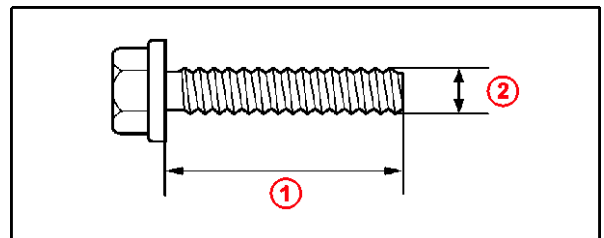

1	Nominal Length
2	Diameter