

Tire Pressure Warning System Activation

Service Category General

Section Pre-Delivery Service

Market USA

Lexus Supports
ASE Certification 

Applicability

YEAR(S)	MODEL(S)	ADDITIONAL INFORMATION
2016	GX460	

Introduction

2016 model year GX 460 vehicles are equipped with a direct-type Tire Pressure Warning System (TPWS). Each tire (including the spare tire) has a tire pressure warning valve/sensor that measures tire pressure. The data is transmitted to the Tire Pressure Warning System antenna/receiver and then to the Tire Pressure Warning System ECU.

During Pre-Delivery Service (PDS), the tire pressure warning valves/sensors must be activated according to the procedure in this bulletin.

Warranty Information

OP CODE	DESCRIPTION	TIME	OFF	T1	T2
N/A	Not Applicable to Warranty	–	–	–	–

Required Tools & Equipment

REQUIRED EQUIPMENT	SUPPLIER	PART NUMBER	QTY
Techstream 2.0*	ADE	TS2UNIT	1
Techstream Lite		TSLITEPDLR01	

* Essential SST.

NOTE

- Only ONE of the Techstream units listed above is required.
- Software version 10.10.018 or later is required.
- Additional Techstream units may be ordered by calling Approved Dealer Equipment (ADE) at 1-800-368-6787.

Tire Pressure Warning System Activation

Reference

- After cycling the ignition to the "IG-ON" position, the Low Tire Pressure Warning Light will blink for one minute and remain illuminated, until all the tire pressure warning valves/sensors are activated.
- The Diagnostic Trouble Codes (DTCs) listed below may be stored in the TPWS ECU until the tire pressure warning valves/sensors are activated.
- The DTCs will automatically clear when the tire pressure warning valves/sensors are activated.

Figure 1.

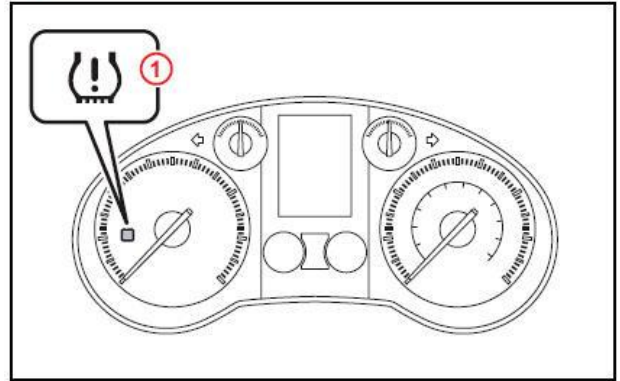

1	Low Tire Pressure Warning Light
----------	--

DTC NO. *1	DTC NO. *2	DTC EXPLANATION
11	C2111	Transmitter ID1 Operation Stop
12	C2112	Transmitter ID2 Operation Stop
13	C2113	Transmitter ID3 Operation Stop
14	C2114	Transmitter ID4 Operation Stop
15	C2115	Transmitter ID5 Operation Stop

*1: DTC No. indicated by blinking of the Low Tire Pressure Warning Light.

*2: DTC No. indicated on Techstream.

Tire Pressure Warning System Activation

Activation Procedure

1. Connect Techstream.
2. Cycle the ignition switch to the "IG-ON" position and check that the Low Tire Pressure Warning Light blinks for 1 minute, and then remains illuminated.

Figure 2.

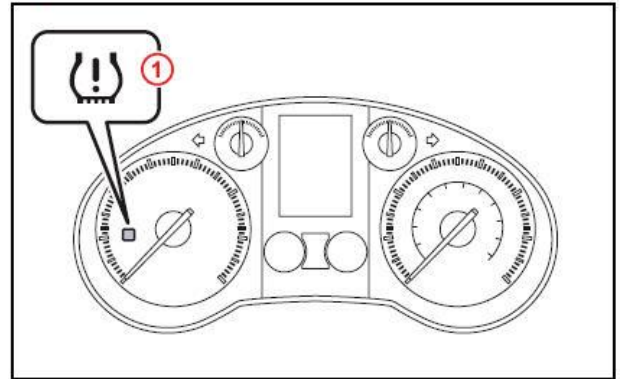

1 Low Tire Pressure Warning Light

3. Press or remove the valve core to reduce the tire inflation pressure rapidly by 6 psi (0.4 kgf/cm², 40 kPa), or more, within 30 seconds.

If the tire inflation pressure is NOT reduced by 6 psi (0.4 kgf/cm², 40 kPa), or more, within 30 seconds, the tire pressure warning valves/sensors will NOT be activated.

NOTE

This operation is required for the system to be activated and must be performed for each tire (including the spare tire), one at a time.

Figure 3.

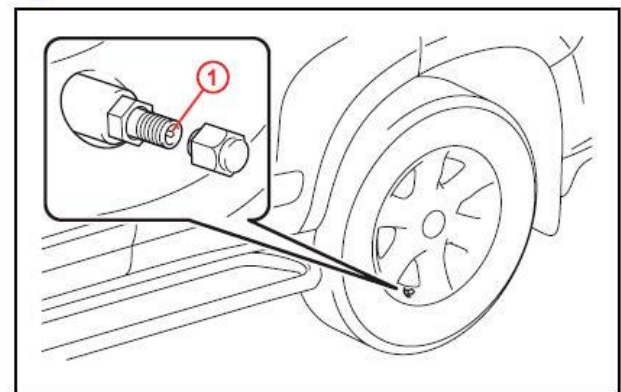

1 Core

4. Using Techstream, check for TPWS DTCs.
 - If NO DTCs are stored, go to step 5.
 - If DTCs C2111 – C2115 are stored, repeat step 3.
5. Adjust all tires (including the spare tire) to the standard tire inflation pressure as indicated on the Tire and Loading Information label on the vehicle. Confirm that the Low Tire Pressure Warning Light is OFF.

Tire Pressure Warning System Activation

Activation Procedure (Continued)

NOTE

- To adjust tire pressure correctly when outside temperature is significantly colder than shop temperature, perform a Health Check using Techstream and select the “Compensation Tire Pressure” checkbox. Compensation pressures will be displayed on the Health Check results screen.
- Adjust the tire pressure when the tires are cold.