

Moon Roof Assembly Structure Noise

Service Category Vehicle Exterior

Section Exterior Panels/Trim

Market USA

Toyota Supports
 ASE Certification 

Applicability

YEAR(S)	MODEL(S)	ADDITIONAL INFORMATION
2013 – 2015	Avalon, Avalon HV	WMI(s): 4T1
2012 – 2016	Camry, Camry HV	WMI(s): 4T1, 4T4

REVISION NOTICE

November 18, 2015 Rev2:

- Applicability has been updated to include 2014, 2015, and 2016 model year Camry and Camry HV and 2013-2015 Avalon and Avalon HV vehicles.
- The Production Change Information section has been updated.

December 17, 2013 Rev1:

- Applicability has been updated to include 2013 model year Camry and Camry HV vehicles.
- The Production Change Information section has been added.

Any previous printed versions of this bulletin should be discarded.

Introduction

Some 2012 – 2016 model year North American produced (NAP) Camry and Camry HV vehicles and 2013 – 2015 Avalon and Avalon HV vehicles may exhibit a knocking, popping, ticking, or snapping noise from the moon roof area while driving. The repair procedure included in this bulletin has been developed to address this condition.

Moon Roof Assembly Structure Noise

Production Change Information

This bulletin applies to vehicles produced **BEFORE** the Production Change Effective VINs shown below.

MODEL	PLANT	LINE	ENGINE	PRODUCTION CHANGE EFFECTIVE VIN
Camry	TMMK	1	4 Cyl	4T1BF1FK#GU133508
			V6	4T1BK1FK#GU030194
		2	4 Cyl	4T1BF1FK#GU515061
			V6	4T1BK1FK#GU569888
	SIA	-	HV	4T1BD1FK#GU179126
			4 Cyl	4T4BF1FK#GR523397
Avalon	TMMK	1	V6	4T1BK1EB#FU185834
			HV	4T1BD1EB#FU047505

Warranty Information

OP CODE	DESCRIPTION	MODEL	TIME	OFF	T1	T2
BD1517	Remove and Reinstall Sliding Roof Housing Sub-Assembly	Camry	4.2	63111-06540	91	57
BD1518		Camry HV				
BD1519		Avalon	4.8			
BD1519		Avalon HV	4.9			
BD1517A	Flex Roof Reinforcements and Install Shims	Camry	0.3			
BD1517A		Camry HV				
BD1518A		Avalon				
BD1519A		Avalon HV				

APPLICABLE WARRANTY

- This repair is covered under the Toyota Basic Warranty. This warranty is in effect for 36 months or 36,000 miles, whichever occurs first, from the vehicle's in-service date.
- Warranty application is limited to occurrence of the specified condition described in this bulletin.

Parts Information

PART NUMBER	PART NAME	QTY
08231-00801	Interior Noise Kit	1
63021-06030	Silencer Sub-Assy, Slide Roof (Shim Kit)	1

Moon Roof Assembly Structure Noise

Repair Procedure

1. Confirm that the noise is coming from the moon roof area.
2. Remove the sliding roof housing.

Refer to the Technical Information System (TIS), applicable model and model year Repair Manual:

- [2012](#) / [2013](#) / [2014](#) / [2015](#) / [2016 Camry](#):
Vehicle Exterior – Sliding Roof/Convertible – “Sliding Roof/Convertible: Sliding Roof Housing: Removal”
 - [2012](#) / [2013](#) / [2014](#) / [2015](#) / [2016 Camry HV](#):
Vehicle Exterior – Sliding Roof/Convertible – “Sliding Roof/Convertible: Sliding Roof Housing: Removal”
 - [2013](#) / [2014](#) / [2015](#) / [Avalon](#):
Vehicle Exterior – Sliding Roof/Convertible – “Sliding Roof/Convertible: Sliding Roof Housing: Removal”
 - [2013](#) / [2014](#) / [2015](#) / [Avalon HV](#):
Vehicle Exterior – Sliding Roof/Convertible – “Sliding Roof/Convertible: Sliding Roof Housing: Removal”
3. Flex and manipulate the roof structure to separate the coating between the roof reinforcements. Continue manipulating the roof structure until the crackling noise goes away. Refer to the video for a demonstration of this procedure.

[Demonstration of Flexing Roof Structure](#)

4. Clean out any remaining debris from the roof reinforcements with an air hose blow nozzle.
5. Install the shims in the following locations.

Moon Roof Assembly Structure Noise

Repair Procedure (Continued)

Figure 1.

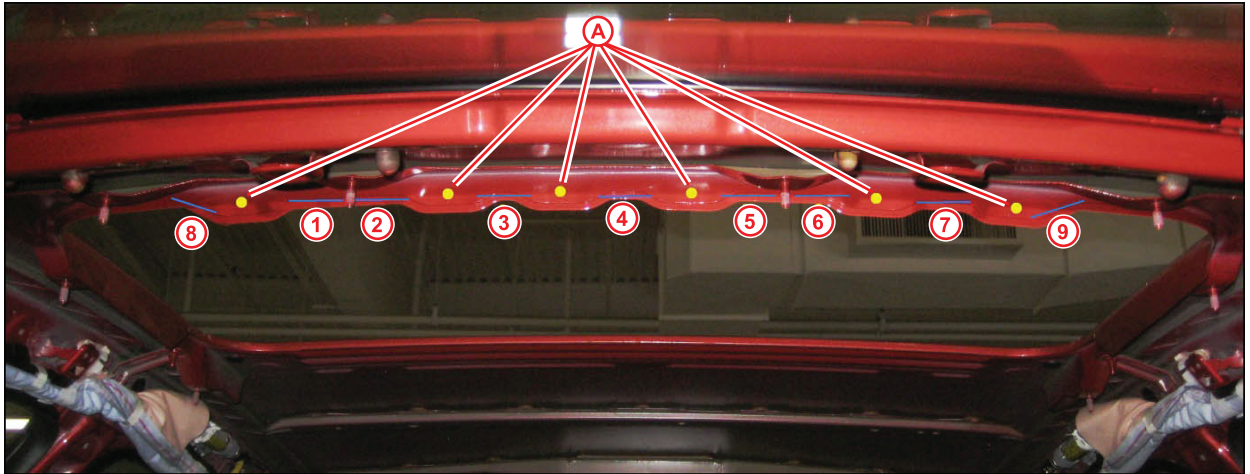

1-9	Shim Installation Locations
-----	-----------------------------

A	Spot Welds
---	------------

- A. At positions 1 – 7 (shown in Figure 1), insert the 7 shims between the spot welds.
Shims 1 – 7: Smaller Rectangle, 12.7 x 43.2 mm (0.5 x 1.7 in.)

NOTE
 At positions 1 – 2 and 5 – 6, two shims are positioned side by side with NO spot weld between them.

Figure 2.

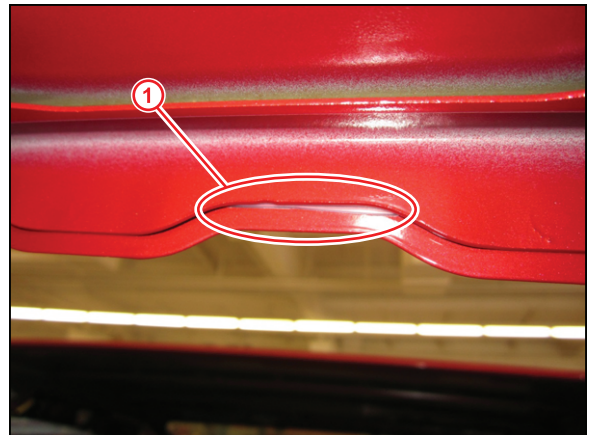

1	Example of Installed Shim
---	---------------------------

- B. At positions 8 and 9 (shown in Figure 1), insert the 2 triangular shims to the outboard sides of the spot welds.
Shims 8 and 9: Triangle

Moon Roof Assembly Structure Noise

Repair Procedure (Continued)

Figure 3.

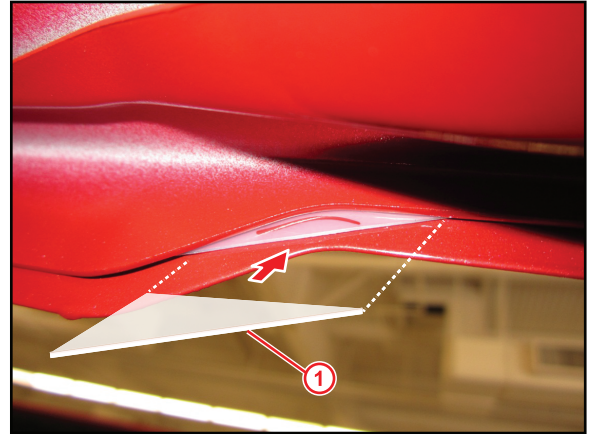

1	Triangular Shim
----------	------------------------

- C. At positions 10 and 11 (shown in Figure 4) on both the RH and LH sides of the moon roof reinforcement structure, insert the 4 shims between the spot welds as indicated.

Shims 10 and 11: Larger Rectangle, 25.4 x 63.5 mm (1.0 x 2.5 in.)

NOTE

LH side is shown.

Figure 4.

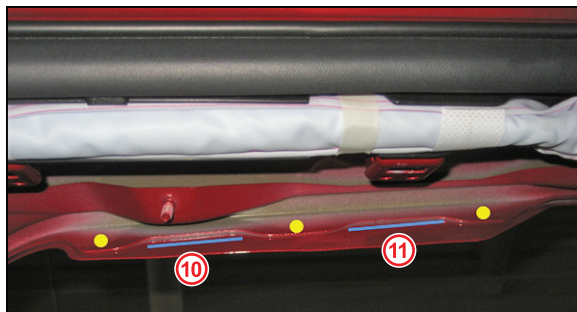
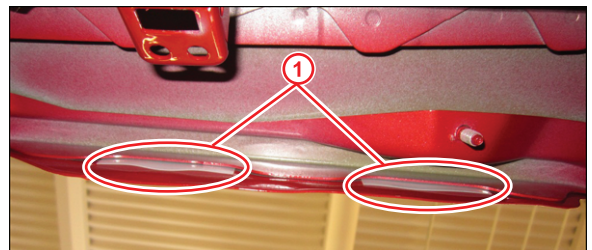

Figure 5.



1	Example of Installed Shims
----------	-----------------------------------

Moon Roof Assembly Structure Noise

Repair Procedure (Continued)

6. From the Interior Noise Kit, use 2 felt strips with the following dimensions:

Length: 300 mm (12.00 in.)

Width: 32 mm (1.25 in.)

Thickness: 0.5 mm (0.02 in. thinnest felt sheet material in the kit)

Temporarily peel back the backing paper at both ends and make a cut in the backing paper ONLY, 2 inches (50.8 mm) away from the ends. Place the backing paper back on the felt.

NOTICE
Do NOT cut the felt, ONLY the backing paper.

Figure 6.

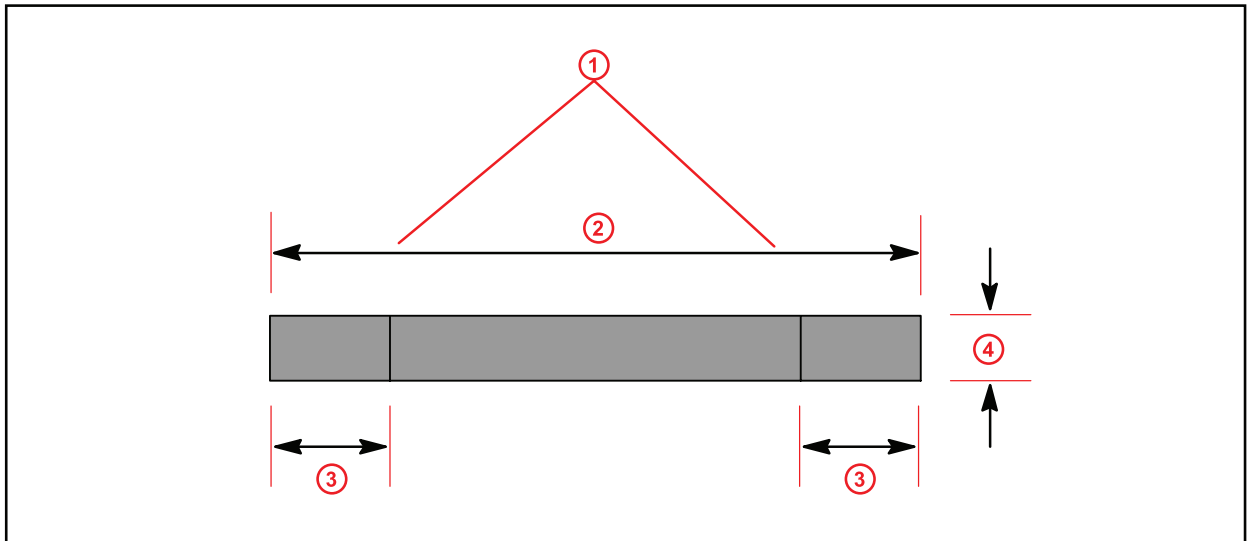

1	Cut Backing Here Before Installing on Roof
2	12.0 in. (300 mm)

3	2.0 in. (50.8 mm)
4	1.25 in. (32 mm)

Moon Roof Assembly Structure Noise

Repair Procedure (Continued)

- Place the felt strips on both corners of the roof structure, between the roof panel and the moon roof mounting structure panel.

NOTICE

Use caution when pulling down on the moon roof mounting structure in the front mounting stud area (to make space for the felt to slide into place) to prevent damage to the roof outer sheet metal.

Once the felt is placed as close to the inner edge as possible, peel off the backing paper at the ends of the felt strip and attach the felt to the roof panel.

NOTE

Do NOT remove the backing paper in the middle of the felt strip.

Figure 7. View Above Driver's Seat



1	Felt Strip
----------	-------------------

Figure 8.

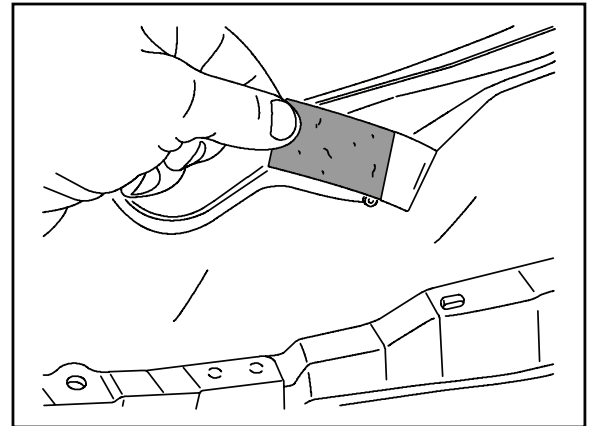

- Perform the felt repair on both front corners of the moon roof structure.

Moon Roof Assembly Structure Noise

Repair Procedure (Continued)

9. Temporarily install the sliding roof housing sub-assembly with the 8 nuts and 8 bolts.

Tighten the RH nut first and then the LH nut shown circled in the Figure below.

Torque: 5.5 N*m (56 kgf*cm, 49 in*lbf)

Figure 9.

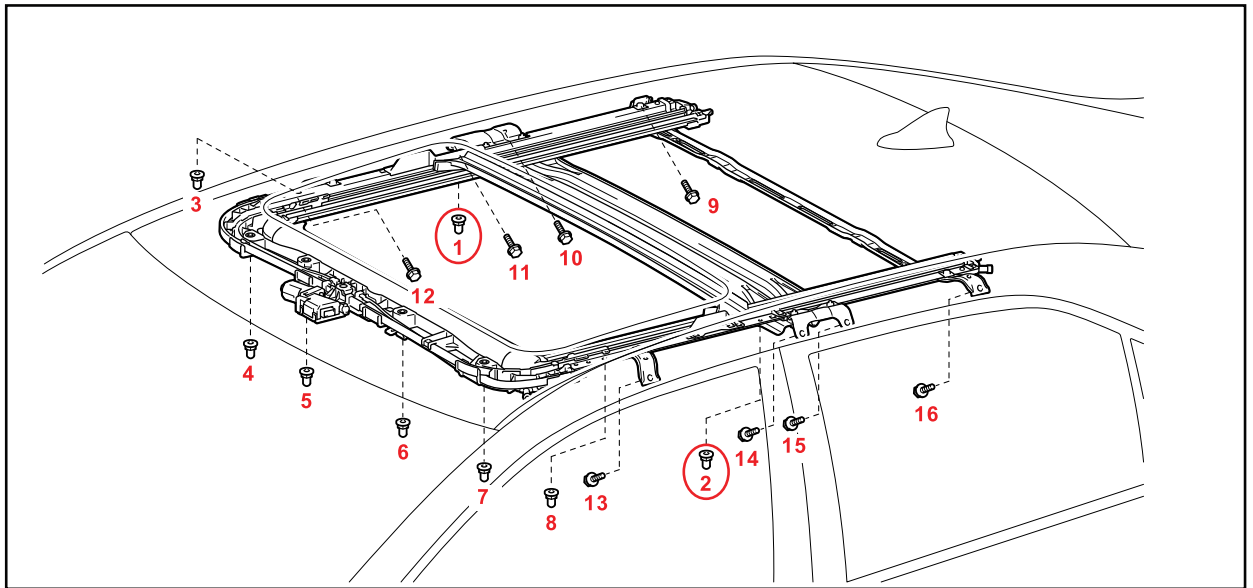

NOTE

RH and LH rear nuts must be tightened before any other moon roof assembly fasteners are tightened.

Moon Roof Assembly Structure Noise

Repair Procedure (Continued)

10. Tighten the remaining 6 nuts.

Torque: 5.5 N*m (56 kgf*cm, 49 in*lbf)

Figure 10.

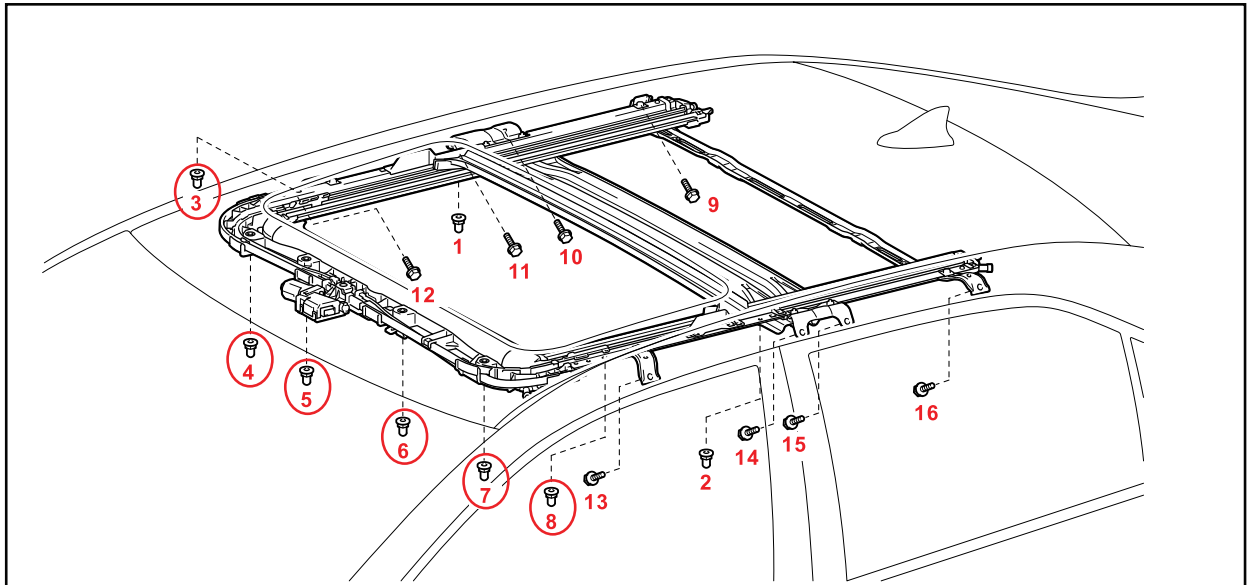

Moon Roof Assembly Structure Noise

Repair Procedure (Continued)

11. Tighten the 8 bolts in the order sequence shown below.

Torque: 8.0 N*m (82 kgf*cm, 71 in*lbf)

Figure 11.

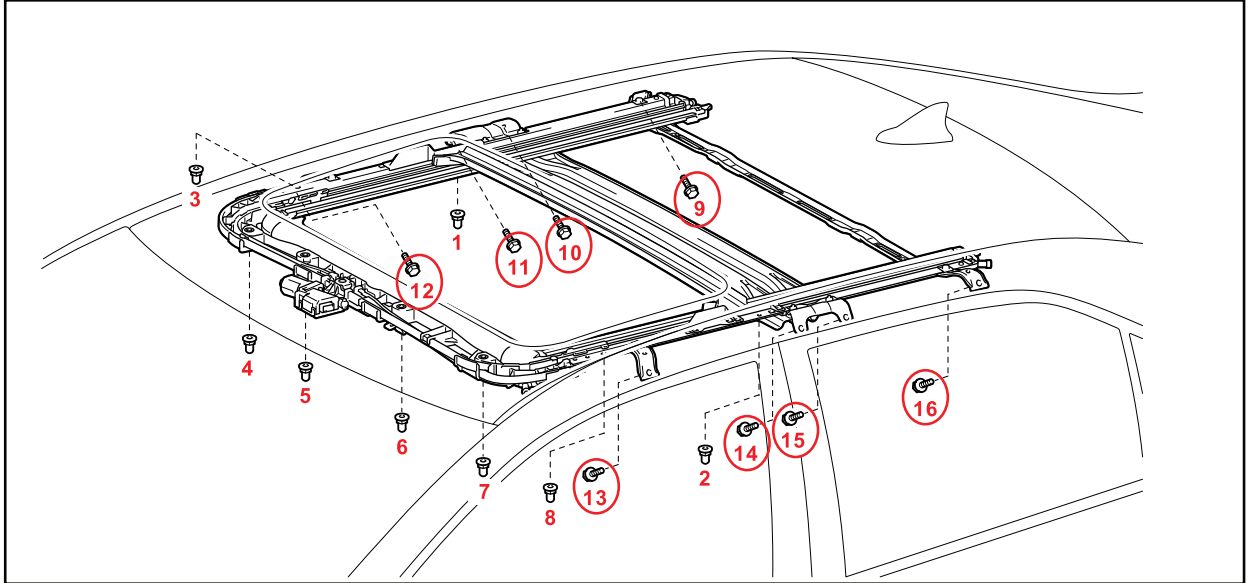

Moon Roof Assembly Structure Noise

Repair Procedure (Continued)

12. Tighten the 8 bolts of the brackets in the order sequence shown below.

Torque: 8.0 N*m (82 kgf*cm, 71 in*lbf)

Figure 12.

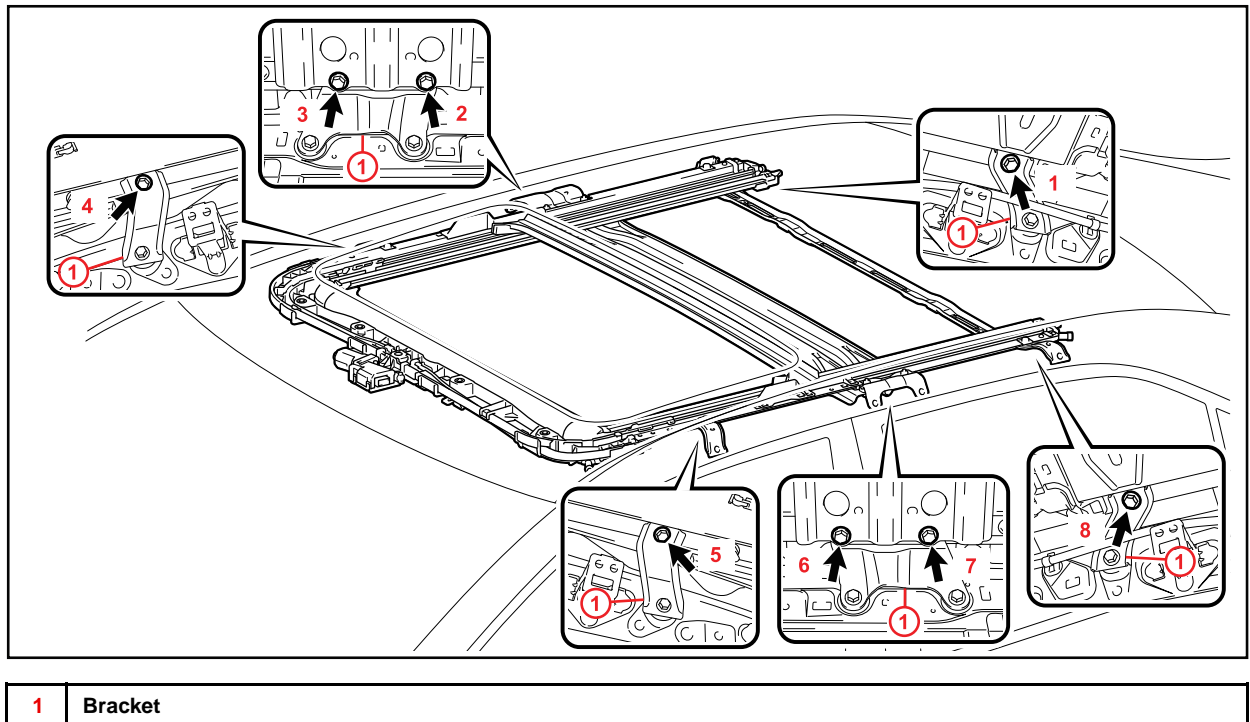

13. Install the remainder of the sliding roof components.

Refer to TIS, applicable model and model year Repair Manual:

- [2012 / 2013 / 2014 / 2015 / 2016 Camry](#):
Vehicle Exterior – Sliding Roof/Convertible – “Sliding Roof/Convertible: Sliding Roof Housing: Install”
- [2012 / 2013 / 2014 / 2015 / 2016 Camry HV](#):
Vehicle Exterior – Sliding Roof/Convertible – “Sliding Roof/Convertible: Sliding Roof Housing: Install”
- [2013 / 2014 / 2015 / Avalon](#):
Vehicle Exterior – Sliding Roof/Convertible – “Sliding Roof/Convertible: Sliding Roof Housing: Install”
- [2013 / 2014 / 2015 / Avalon HV](#):
Vehicle Exterior – Sliding Roof/Convertible – “Sliding Roof/Convertible: Sliding Roof Housing: Install”

14. Test drive the vehicle to verify repair.