

**ATTENTION:**  
 GENERAL MANAGER   
 PARTS MANAGER   
 CLAIMS PERSONNEL   
 SERVICE MANAGER

IMPORTANT - All Service Personnel Should Read and Initial in the boxes provided, right.

© 2015 Subaru of America, Inc. All rights reserved.



QUALITY DRIVEN® SERVICE

## SERVICE INFORMATION

**APPLICABILITY:** 2015MY WRX and STI Models

**NUMBER:** 12-188-15

**SUBJECT:** Side Spoiler Removal Instructions and Precautions

**DATE:** 09/23/15

### INTRODUCTION:

This Service Information bulletin provides instructions and precautions to help protect the paint finish and the adjacent body garnish edge areas when removing or reinstalling the side spoiler assembly.

### SERVICE PROCEDURE / INFORMATION:

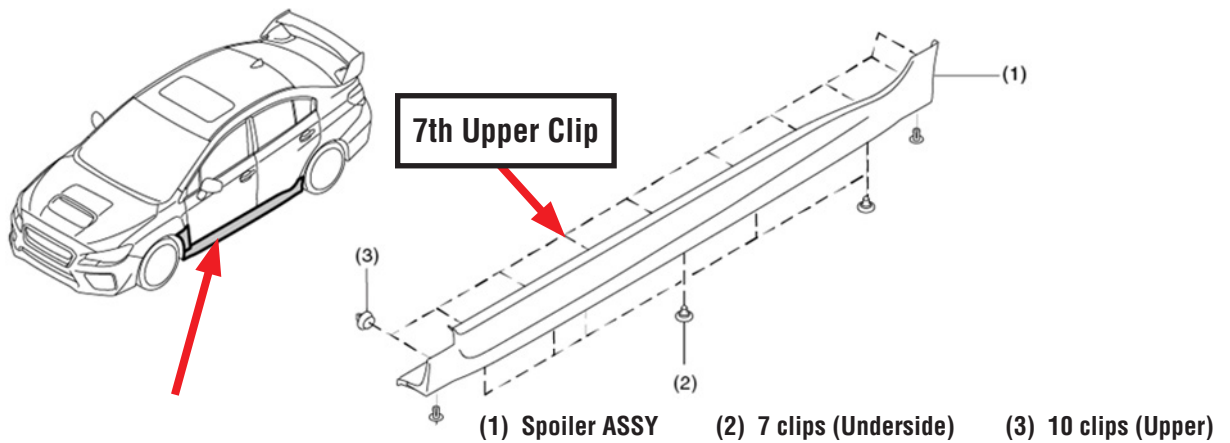

There are 2 methods for protecting the paint finish when removing the side spoiler. Both involve the use of blue Painter's Tape applied to the front gap area of the spoiler as shown in the photos and illustrations below. The blue Painter's Tape (available at any home improvement retailer) is recommended because the adhesive used does not leave any residue behind when removed from the surface it is applied to.

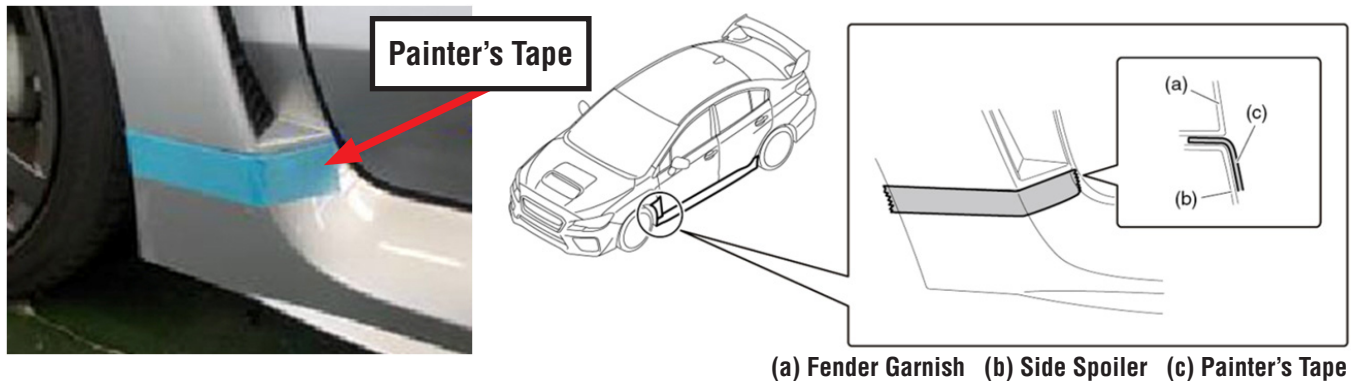

*Continued...*

**CAUTION: VEHICLE SERVICING PERFORMED BY UNTRAINED PERSONS COULD RESULT IN SERIOUS INJURY TO THOSE PERSONS OR TO OTHERS.**

Subaru Service Bulletins are intended for use by professional technicians ONLY. They are written to inform those technicians of conditions that may occur in some vehicles, or to provide information that could assist in the proper servicing of the vehicle. Properly trained technicians have the equipment, tools, safety instructions, and know-how to do the job correctly and safely. If a condition is described, DO NOT assume that this Service Bulletin applies to your vehicle, or that your vehicle will have that condition.

**SUBARU OF AMERICA, INC. IS ISO 14001 COMPLIANT**

ISO 14001 is the international standard for excellence in Environmental Management Systems. Please recycle or dispose of automotive products in a manner that is friendly to our environment and in accordance with all local, state and federal laws and regulations.

**Method 1:** CAREFULLY remove the 7 clips from the underside of the spoiler using the necessary screw driver (flat or Phillips head) and a plastic trim tool. After removing the underside clips, if the gap between the garnish and the spoiler still is too tight to get the tape into, use a helper to CAREFULLY press down on the spoiler in the area shown in the photo below opening the gap enough to apply the Painter's tape. 2 pieces of tape were used in the bottom photo insuring both angles of the spoiler edge were protected.

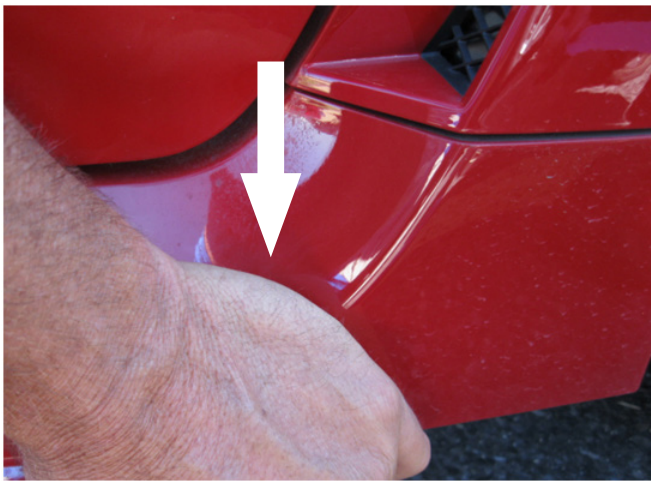

**Method 2:** If the gap is still insufficient to apply the tape, (with the 7 underside clips removed) start from the rear of the spoiler and CAREFULLY release the first 6 upper clips using a plastic trim tool. BEFORE releasing the 7th and remaining clips, there should now be sufficient gap between the front of the spoiler and the fender garnish to install the tape. At this point, the rear of the spoiler must be supported to maintain an approximate 1 ¼" gap (H) between the rear of the spoiler and the front lower edge of the wheel arch. Use either a cloth-covered spacer as shown in the photo and illustration below or a helper (preferred) to support the spoiler while the remaining upper clips are released.

**VERY IMPORTANT:** During spoiler removal or installation, NEVER allow the rear of the spoiler to be unsupported.

*Continued...*

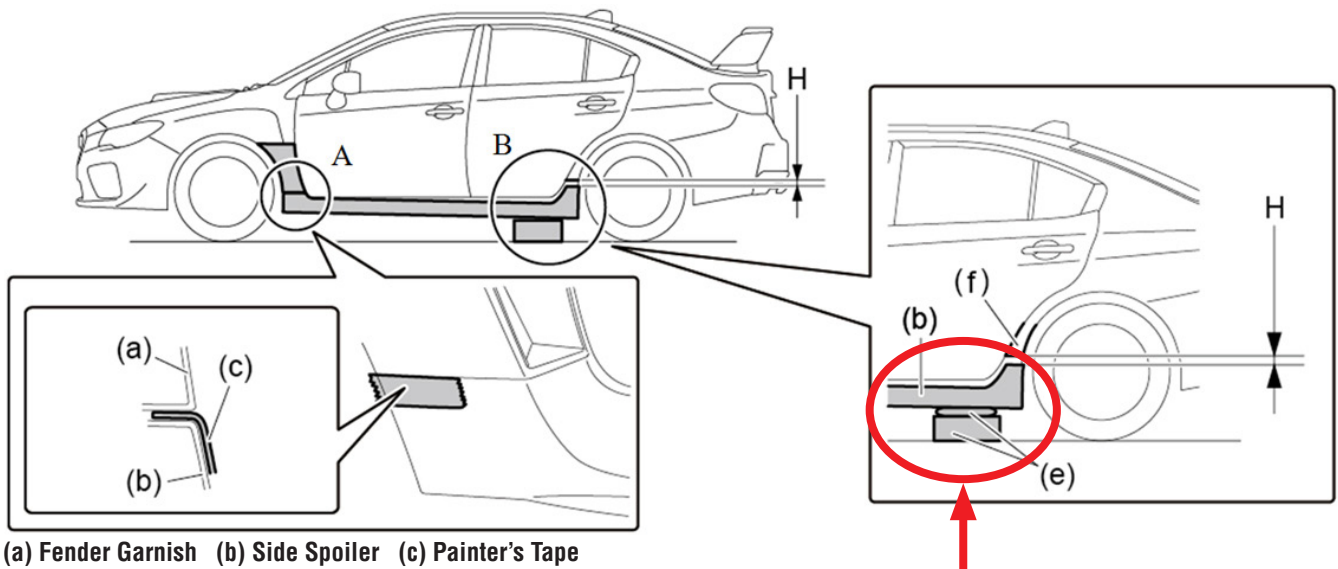

**NOTE:** When reinstalling the spoiler, always make sure all of the Painter's Tape is removed before the spoiler is fully secured into position.

**REMINDER:** SOA strongly discourages the printing and/or local storage of service information as previously released information and electronic publications may be updated at any time.

**Always refer to STIS for the latest service information before performing any repairs.**

*Continued...*