



Service Bulletin

SERVICE UPDATE

SUBJECT: Service Update for Inventory and Customer Vehicles
Incorrect Air Conditioning Vent Assembly
Expires with Base Warranty

MODELS: 2015 Cadillac XTS

This service update includes vehicles in dealer inventory and customer vehicles that return to the dealership for any reason. This bulletin will expire at the end of the involved vehicle's New Vehicle Limited Warranty period.

PURPOSE

This bulletin provides a service procedure to remove the A/C actuator, rotate the bypass door to the full-open position, and reinstall the actuator on **certain** 2015 model year Cadillac XTS vehicles. These vehicles may have been built with an incorrect A/C vent assembly. This condition will prevent adequate heating and cooling for passengers in the rear seats.

This service procedure should be completed as soon as possible on involved vehicles currently in dealer inventory and customer vehicles that return to the dealer for any type of service during the New Vehicle Limited Warranty coverage period.

VEHICLES INVOLVED

All involved vehicles are identified by VIN in the Global Warranty Management System – Investigate Vehicle History Application. Dealership technicians should always check this site to confirm vehicle involvement prior to beginning any required inspections and/or repairs. It is important to routinely use this tool to verify eligibility because not all similar vehicles may be involved regardless of description or option content.

Additionally, a list of involved vehicles currently in dealer inventory is available on the “Service Update Bulletin Information” link under the “Service” tab in GM GlobalConnect (US) or attached to the GlobalConnect message (Canada) used to release this bulletin. Customer vehicles that return for service, for any reason, and are still covered under the vehicle's base warranty should also be checked for vehicle eligibility.

PART INFORMATION

No parts are required for this repair.

SERVICE PROCEDURE

This procedure will permanently affix the AC vent bypass door to the fully open position. The door actuator drive will need to be rotated to align with the opened air door shaft.

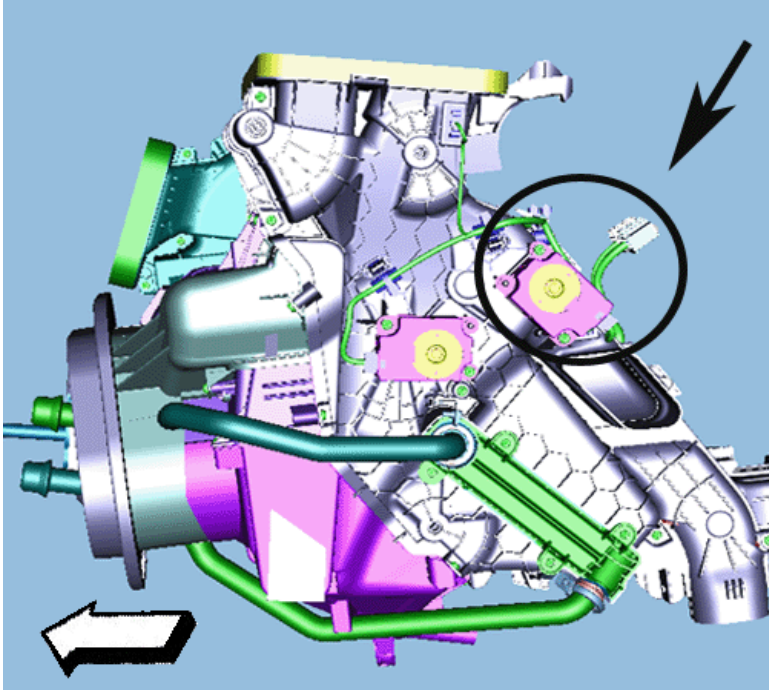

4090315

Reference: AC vent bypass door actuator location

1. Remove the left side floor front air outlet duct. Refer to *Floor Front Air Outlet Duct Replacement - Left Side* in SI.

Note: The console does not have to be removed. The shift cable should be disconnected at the shifter. Refer to *Range Selector Lever Cable Replacement* in SI.

2. Remove the front floor console fasteners and slide the console towards the rear for clearance at the instrument panel. Refer to *Front Floor Console Replacement* in SI.

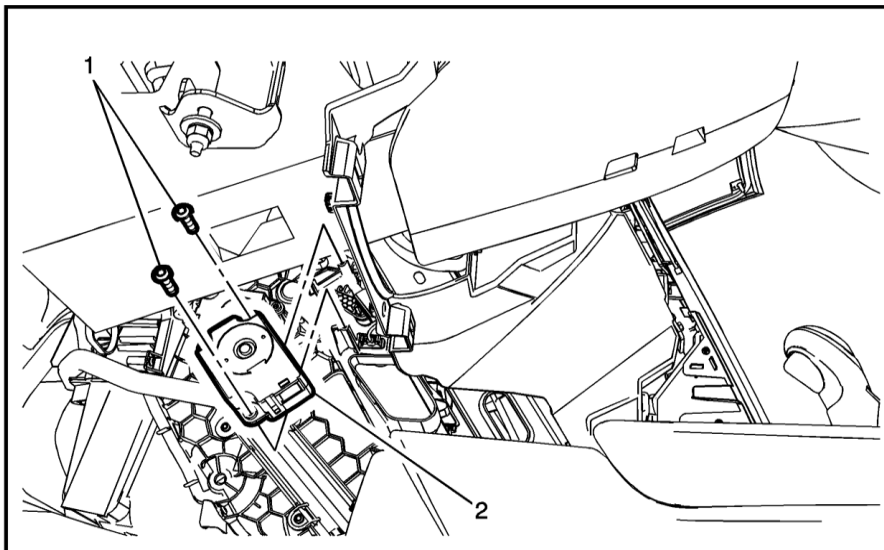
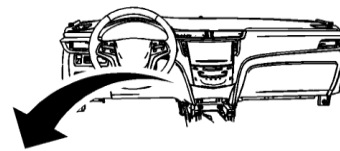

3. Remove the fasteners (1) and the AC vent bypass door actuator (mode valve actuator) (2) from the case. Refer to *Mode Valve Actuator Replacement - Console (With CJ4)* in SI.



4091918

Driver Side Under dash shown

4. Rotate the bypass vent door shaft (1) counter-clockwise to the stop.



4090796

5. Rotate the actuator shaft drive mechanism (1) to align with the vent door shaft.

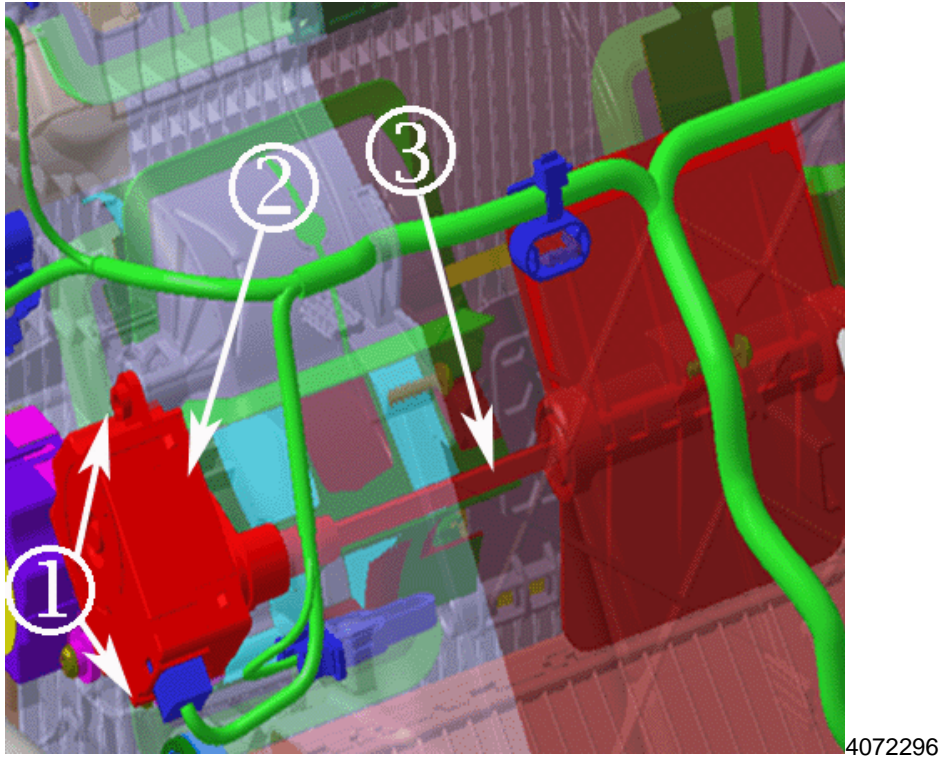

Caution: When using fasteners that are threaded directly into plastic, use extreme care not to strip the mating plastic part(s). Use hand tools only, and do not use any kind of impact or power tools. Fastener should be hand tightened, fully seated, and not stripped.

6. Install the mode valve actuator (2) onto the shaft (3) aligning the mounting holes (1) with the case.
7. Install mode valve actuator fasteners.
8. Install the front floor console fasteners. Refer to *Front Floor Console Replacement* in SI.
9. Install the left side floor front air outlet duct. Refer to *Floor Front Air Outlet Duct Replacement - Left Side* in SI.

WARRANTY TRANSACTION INFORMATION

Submit a transaction using the table below. All transactions should be submitted as a ZFAT transaction type, unless noted otherwise.

Labor Code	Description	Labor Time
9101336	Remove HVAC Door Actuator and Adjust Vent Bypass Door	1.1

DEALER PROGRAM RESPONSIBILITY

Whenever a vehicle subject to this service update enters your vehicle inventory, or is in your facility for service in the future, and the vehicle is still covered under the New Vehicle Limited Warranty, you must take the steps necessary to be sure the service update correction has been made before selling or releasing the vehicle.

GM bulletins are intended for use by professional technicians, NOT a "do-it-yourselfer". They are written to inform these technicians of conditions that may occur on some vehicles, or to provide information that could assist in the proper service of a vehicle. Properly trained technicians have the tools, equipment, safety instructions, and know-how to do a job properly and safely. If a condition is described, **DO NOT** assume that the bulletin applies to your vehicle, or that your vehicle will have that condition. See your dealer for information on whether your vehicle may benefit from the information.



**We Support
Voluntary Technician
Certification**

GM CUSTOMER CARE AND AFTERSALES
DCS3572
URGENT - DISTRIBUTE IMMEDIATELY

Date: March 04, 2015

Subject: 14891– Service Update Bulletin
Incorrect Air Conditioning Vent Assembly

Models: 2015 Cadillac XTS

To: All Cadillac Dealers

Attention: General Manager, Service Advisor, Service Manager, Parts and
Service Director, Parts Manager, New Vehicle Sales Manager,
and Warranty Administrator

General Motors is releasing Service Update Bulletin 14891 today. The total number of U.S. vehicles involved is approximately 127. Please see the attached bulletin for details.

Global Warranty Management (GWM)

The “Investigate Vehicle History” (IVH) screen will be updated March 05, 2015. A list of involved vehicles in dealer inventory is attached to this message.

END OF MESSAGE
GM CUSTOMER CARE AND AFTERSALES