



Service Bulletin

SERVICE UPDATE

SUBJECT: Service Update for Inventory and Customer Vehicles
Insufficient Evaporative Emission Canister Capacity for Vapor Generation

MODELS: 2014-2015 Cadillac ELR
2011-2015 Chevrolet Volt
Expires With Applicable New Vehicle Limited Warranty Coverage Periods,
Including Voltec Component Limited Warranty

The Part Information, Service Procedure and Warranty Transaction Information sections of this bulletin have been revised. Please discard all copies of bulletin 14522A.

This service update includes vehicles in dealer inventory and customer vehicles that return to the dealership for any reason. This bulletin will expire with the Applicable New Vehicle Limited Warranty coverage periods, including Voltec Component Limited Warranty.

PURPOSE

This bulletin provides a service procedure to install an evaporative emissions canister and onboard refueling vapor recovery (ORVR) vent line on certain 2014-2015 model year Cadillac ELR and 2011-2015 Chevrolet Volt vehicles.

This service procedure should be completed as soon as possible on involved vehicles currently in dealer inventory and customer vehicles that return to the dealer for any type of service during Applicable New Vehicle Limited Warranty coverage periods, including Voltec Component Limited Warranty.

VEHICLES INVOLVED

All involved vehicles are identified by VIN in the Global Warranty Management System – Investigate Vehicle History Application. Dealership technicians should always check this site to confirm vehicle involvement prior to beginning any required inspections and/or repairs. It is important to routinely use this tool to verify eligibility because not all similar vehicles may be involved regardless of description or option content.

Additionally, a list of involved vehicles currently in dealer inventory is available on the “Service Update Bulletin Information” link under the “Service” tab in GM GlobalConnect (US) or attached to the GlobalConnect message (Canada) used to release this bulletin.

PART INFORMATION

Parts required to complete this service update are to be obtained from General Motors Customer Care and Aftersales (GMCCA). Please refer to your “involved vehicles listing” before ordering parts. Normal orders should be placed on a DRO = Daily Replenishment Order. In an emergency situation, parts should be ordered on a CSO = Customer Special Order. All dealer orders (placed on or after May 5, 2015) for parts that are being removed from this bulletin will be cancelled. The part numbers affected are 11516078, 11609610 and 11610587. If the order was required for a repair not covered by this bulletin, please enter a new order.

Part Number	Description	Quantity/Vehicle
23294932	Evaporative Emission Canister Assembly	1
23342510	Evaporative Emission Hose Assembly	1

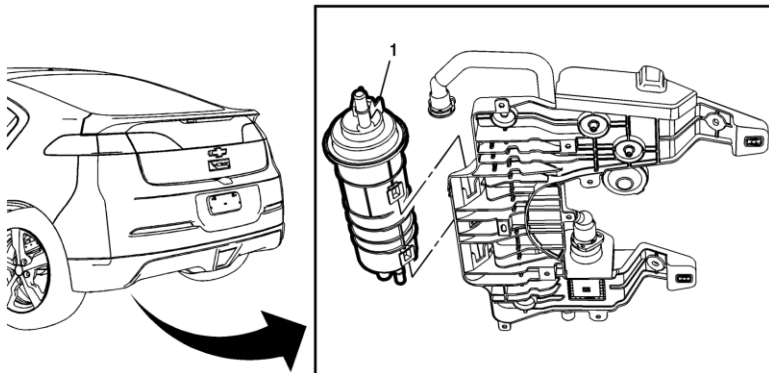
SERVICE PROCEDURE

2440830

1. Remove the evaporative emission canister (1). Refer to *Evaporative Emission Canister Replacement* in SI.

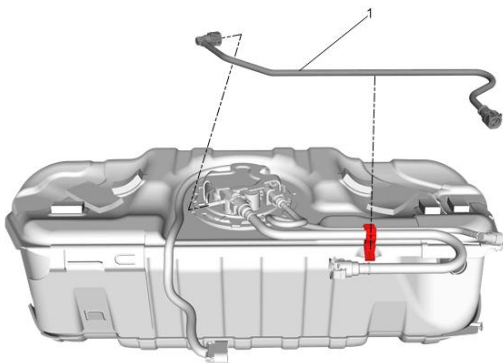

3997266

2. Remove the evaporative emission hose (1). Refer to *Evaporative Emission Hose Replacement* in SI.
3. Install a new evaporative emission hose (1). Refer to *Evaporative Emission Hose Replacement* in SI.

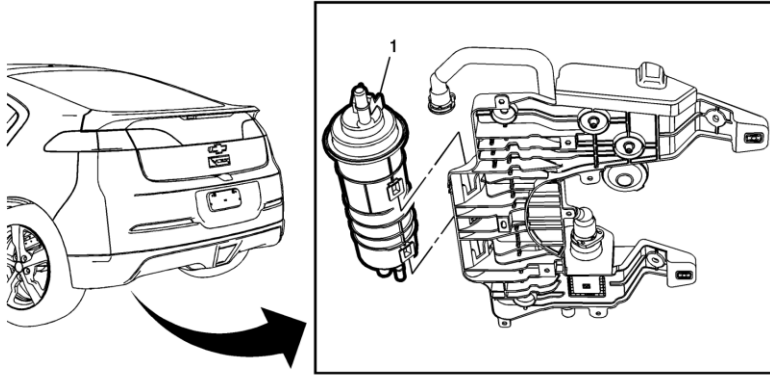

2440830

4. Install a new evaporative emission canister (1). Refer to *Evaporative Emission Canister Replacement* in SI.

WARRANTY TRANSACTION INFORMATION

Submit a transaction using the table below. All transactions should be submitted as a ZFAT transaction type, unless noted otherwise.

Labor Code	Description	Labor Time
9101063	Replace Evaporative Emission Canister and Evaporative Emission Hose	0.5

DEALER PROGRAM RESPONSIBILITY

Whenever a vehicle subject to this service update enters your vehicle inventory, or is in your facility for service in the future, and the vehicle is still covered under Applicable New Vehicle Limited Warranty Coverage Periods, including Voltec Component Limited Warranty, you must take the steps necessary to be sure the service update correction has been made before selling or releasing the vehicle.

GM CUSTOMER CARE AND AFTERSALES
DCS3653
URGENT - DISTRIBUTE IMMEDIATELY

Date: May 8, 2015

Subject: 14522B – Service Update Bulletin
Insufficient Evaporative Emission Canister Capacity for
Vapor Generation
Revised Part Information, Service Procedure and Warranty
Transaction Information Sections

Models: 2014-2015 Cadillac ELR
2011-2015 Chevrolet Volt

To: All Cadillac and Chevrolet Dealers

Attention: General Manager, Service Advisor, Service Manager, Parts and
Service Director, Parts Manager, New Vehicle Sales Manager,
Used Vehicle Sales Manager and Warranty Administrator

The Part Information, Service Procedure and Warranty Transaction sections of
this bulletin have been revised. Please discard all copies of bulletin 14522A.

Labor time updates will be effective May 9, 2015.

END OF MESSAGE
GM CUSTOMER CARE AND AFTERSALES