



Service Bulletin

SERVICE UPDATE

SUBJECT: Service Update for Inventory and Customer Vehicles
Tailpipe Appearance
Expires with Base Warranty

MODELS: 2015 Chevrolet Colorado
2015 GMC Canyon
Equipped with 4-cylinder Engine (RPO LCV)

This service update includes vehicles in dealer inventory and customer vehicles that return to the dealership for any reason. This bulletin will expire at the end of the involved vehicle's New Vehicle Limited Warranty period.

PURPOSE

This bulletin provides a service procedure to replace the muffler and tailpipe assembly on **certain** 2015 model year Chevrolet Colorado and GMC Canyon vehicles equipped with a 4-cylinder engine (RPO LCV). Some vehicles may have been assembled with a muffler and tailpipe assembly that was not coated correctly. This condition could affect the appearance of the tailpipe over time.

This service procedure should be completed as soon as possible on involved vehicles currently in dealer inventory and customer vehicles that return to the dealer for any type of service during the New Vehicle Limited Warranty coverage period.

VEHICLES INVOLVED

All involved vehicles are identified by VIN in the Global Warranty Management System – Investigate Vehicle History Application. Dealership technicians should always check this site to confirm vehicle involvement prior to beginning any required inspections and/or repairs. It is important to routinely use this tool to verify eligibility because not all similar vehicles may be involved regardless of description or option content.

Additionally, a list of involved vehicles currently in dealer inventory is available on the “Service Update Bulletin Information” link under the “Service” tab in GM GlobalConnect (US) or attached to the GlobalConnect message (Canada) used to release this bulletin. Customer vehicles that return for service, for any reason, and are still covered under the vehicle's base warranty should also be checked for vehicle eligibility.

PART INFORMATION

Parts required to complete this service update are to be obtained from General Motors Customer Care and Aftersales (GMCCA). Please refer to your “involved vehicles listing” before ordering parts. Normal orders should be placed on a DRO = Daily Replenishment Order. In an emergency situation, parts should be ordered on a CSO = Customer Special Order.

| Part Number | Description | Quantity/Vehicle |
|-------------|---------------------------|------------------|
| 94779902 | MUFFLER, EXH (W/EXH PIPE) | 1 |

SERVICE PROCEDURE

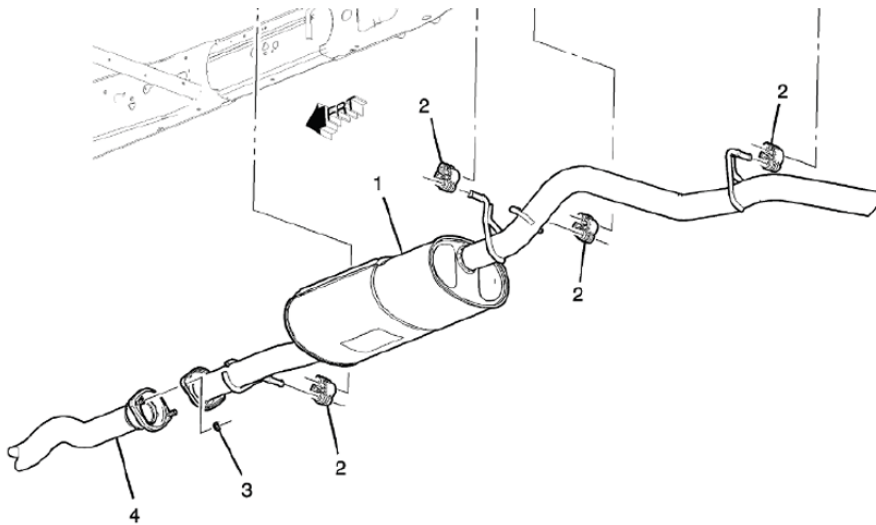

4140229

1. Replace the muffler and tailpipe assembly. Refer to *Exhaust Muffler Replacement (LCV)* in SI.

WARRANTY TRANSACTION INFORMATION

Submit a transaction using the table below. All transactions should be submitted as a ZFAT transaction type, unless noted otherwise.

| Labor Code | Description | Labor Time |
|------------|---------------------------------------|------------|
| 9101426 | Replace Muffler and Tailpipe Assembly | 0.5 |

DEALER PROGRAM RESPONSIBILITY

Whenever a vehicle subject to this service update enters your vehicle inventory, or is in your facility for service in the future, and the vehicle is still covered under the New Vehicle Limited Warranty, you must take the steps necessary to be sure the service update correction has been made before selling or releasing the vehicle.

GM bulletins are intended for use by professional technicians, NOT a "do-it-yourselfer". They are written to inform these technicians of conditions that may occur on some vehicles, or to provide information that could assist in the proper service of a vehicle. Properly trained technicians have the tools, equipment, safety instructions, and know-how to do a job properly and safely. If a condition is described, **DO NOT** assume that the bulletin applies to your vehicle, or that your vehicle will have that condition. See your dealer for information on whether your vehicle may benefit from the information.



We Support
Voluntary Technician
Certification

GM CUSTOMER CARE AND AFTERSALES
DCS3690
URGENT - DISTRIBUTE IMMEDIATELY

Date: June 26, 2015

Subject: 15184 – Service Update Bulletin
Tailpipe Appearance

Models: 2015 Chevrolet Colorado
2015 GMC Canyon
Equipped with 4-cylinder Engine (RPO LCV)

To: All Chevrolet and GMC Dealers

Attention: General Manager, Service Advisor, Service Manager, Parts and
Service Director, Parts Manager, New Vehicle Sales Manager
and Warranty Administrator

General Motors is releasing Service Update Bulletin 15184 today. The total number of U.S. vehicles involved is approximately 9,357. Please see the attached bulletin for details.

Global Warranty Management (GWM)

The “Investigate Vehicle History” (IVH) screen will be updated June 27, 2015. A list of involved vehicles in dealer inventory is attached to this message.

END OF MESSAGE
GM CUSTOMER CARE AND AFTERSALES