



Program Bulletin

CUSTOMER SATISFACTION PROGRAM

SUBJECT: Backup Alarm Not Installed On Vehicle

MODELS: 2015 Chevrolet Colorado
2015 GMC Canyon
Equipped with Backup Alarm (SEO 8S3)

.....
THIS PROGRAM IS IN EFFECT UNTIL JUNE 30, 2017.
.....

CONDITION

Certain 2015 model year Chevrolet Colorado and GMC Canyon model vehicles equipped with a Backup Alarm SEO 8S3 may have a condition in which the backup alarm module was not installed to the vehicle during assembly.

CORRECTION

Dealers are to install the backup alarm assembly using the service procedure outlined in this bulletin.

VEHICLES INVOLVED

All involved vehicles are identified by Vehicle Identification Number on the Investigate Vehicle History screen in GM Global Warranty Management system. Dealership service personnel should always check this site to confirm vehicle involvement prior to beginning any required inspections and/or repairs. It is important to routinely use this tool to verify eligibility because not all similar vehicles may be involved regardless of description or option content.

For dealers with involved vehicles, a listing with involved vehicles containing the complete vehicle identification number, customer name, and address information has been prepared and will be provided to US and Canadian dealers through the GM GlobalConnect Recall Reports. Dealers will not have a report available if they have no involved vehicles currently assigned.

The listing may contain customer names and addresses obtained from Motor Vehicle Registration Records. The use of such motor vehicle registration data for any purpose other than follow-up necessary to complete this program is a violation of law in several states/provinces/countries. Accordingly, you are urged to limit the use of this report to the follow-up necessary to complete this program.

PART INFORMATION

Parts Pre-Ship Information – For US and Canada

Important: An initial supply of parts required to complete this recall will be pre-shipped to the 4 involved dealers of record. This pre-shipment began June 9, 2015. Pre-shipped parts will be charged to dealer's open parts account.

Additional parts, if required, are to be obtained from GMCC&A. Please refer to your “involved vehicles listing” before ordering parts. Normal orders should be placed on a DRO = Daily Replenishment Order. In an emergency situation, parts should be ordered on a CSO = Customer Special Order.

Part Number	Description	Quantity/Vehicle
12101855	CONNECTOR-MDL-ELEK IGN CONT	1 (If Req'd)
22799757	HARNESS ASM-B/U ALARM WRG	1 (If Req'd)
25824475	ALARM ASM-B/U	1
11570903	BOLT	2
11546377	NUT	2
01839906	SPLICE CLIP	1 (If Req'd)
19300089	SPLICE CONNECTOR (SALMON)	1 (If Req'd)
12354999	SHRINK TUBING	1 (If Req'd)
8919354	CONDUIT	1 (If Req'd)

SERVICE PROCEDURE

Vehicles Built Without RPO Z82 Trailering Option

1. Disconnect the negative battery cable. Refer to *Battery Negative Cable Disconnection and Connection* in SI.
2. Raise and support the vehicle. Refer to *Lifting and Jacking the Vehicle* in SI.
3. Remove the spare tire. Refer to *Spare Wheel Carrier Hanger Replacement (Pickup)* in SI.

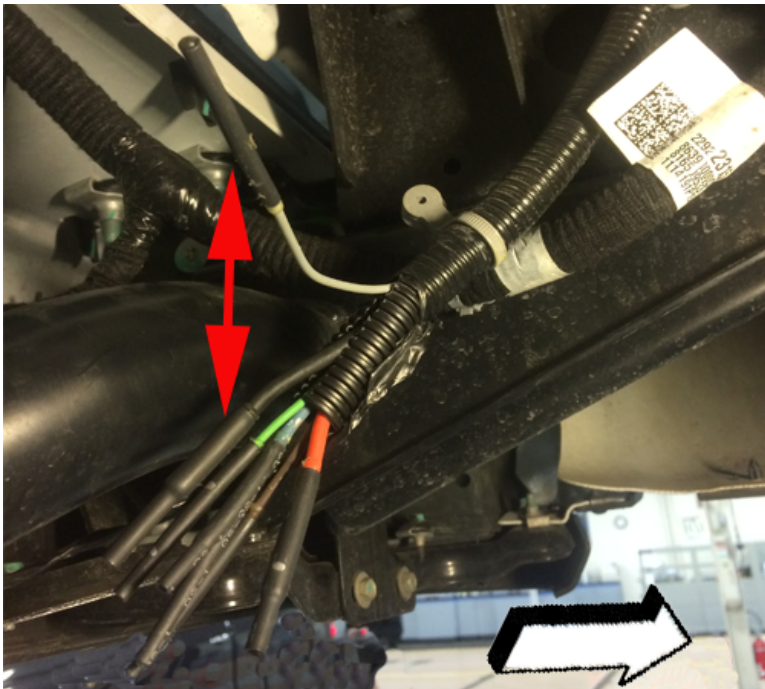

4195318

4. Locate the blunt-cut trailer harness extending from the conduit located under the truck bed along the left rear frame rail at the trailer hitch area.
5. Remove any tape, and identify the thin grey (CKT 1624), and thick black (CKT 22A) wires.
6. Remove the shrink tubing from the ends of the two wires using a suitable tool.
7. Strip approximately 5.0 mm (0.20 in) of insulation from the end of each wire.

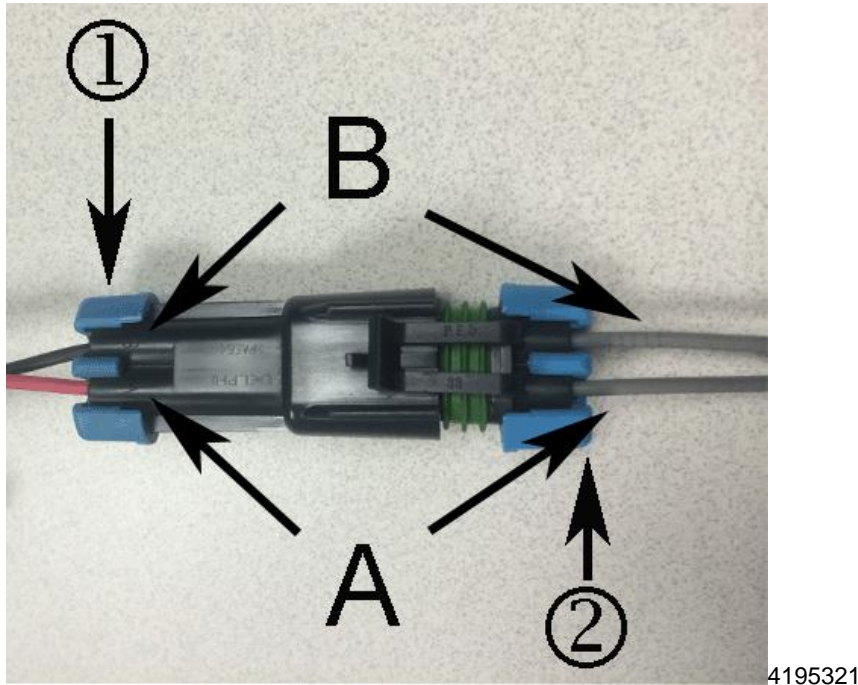

Backup alarm connector (1) terminals A/B shown with 12101855 connector (2).

8. Strip approximately 5.0 mm (0.20 in) of insulation from the end of each 12101855 connector wire.
9. Splice 12101855 connector wire going to terminal A of alarm to the thin gray wire (CKT 1624) of the vehicle harness with the salmon 19300089 Duraseal connector. Refer to *Splicing Copper Wire Using Splice Sleeves* in SI for splicing instructions.

Note: BEFORE performing step 10, insert 3 ½" length of shrink tubing over wire. Only use heat shrink tube P/N 12354999, or an equivalent flexible adhesive-lined/moisture resistant heat shrink tube to perform the repair in this bulletin.

10. Splice 12101855 connector wire going to terminal B of alarm to the thick black wire (CKT 22A) of the vehicle harness using splice clip 01839906.

Caution: Use only the EL-28125-5 Ultra Torch or another butane fueled soldering iron to splice the terminal leads to avoid inducing voltage into the circuit, which may damage electrical components.

Note: Keep the heat shrink away from the splice when soldering to ensure that it is not prematurely shrunk and closed down over the wire or the splice area due to the heat from the soldering iron.

11. Solder splice clip connection on black wire.
12. Position shrink tube midpoint over soldered connection on black wire.
13. Seal the shrink tube with the Ultra Torch.
14. Seal the Duraseal connection with the Ultra Torch.
15. Install a length of wiring conduit over the exposed harness wires.

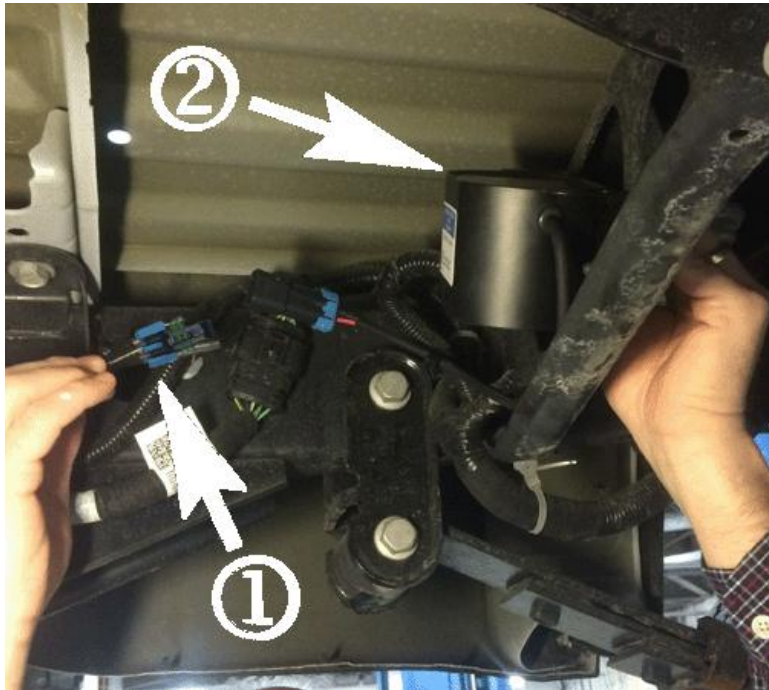

4195326

Backup alarm (2) and harness connector (1).

16. Install the backup alarm to the existing holes of the rear frame crossmember with the mounting nuts and bolts. The crossmember mounting location is near the leaf spring rear shackles. The alarm speaker must be pointing down.
17. Connect the rear harness connector (1) to the alarm (2) harness.
18. Tie strap the complete alarm harness to the existing wiring harness, securing it every 3 inches.
19. Lower the vehicle.
20. Connect the negative battery cable. Refer to *Battery Negative Cable Disconnection and Connection* in SI.
21. Turn the ignition to ON/RUN, and place gear selector into REVERSE to engage the backup alarm.
22. Raise the vehicle and install the spare tire. Refer to *Spare Wheel Carrier Hanger Replacement (Pickup)* in SI.

Vehicles Built With Z82 Trailering Option

1. Disconnect the negative battery cable. Refer to *Battery Negative Cable Disconnection and Connection* in SI.
2. Raise and support the vehicle. Refer to *Lifting and Jacking the Vehicle* in SI.
3. Remove the spare tire. Refer to *Spare Wheel Carrier Hanger Replacement (Pickup)* in SI.
4. Locate the trailer harness located under the truck bed along the left rear frame rail at the trailer hitch area.

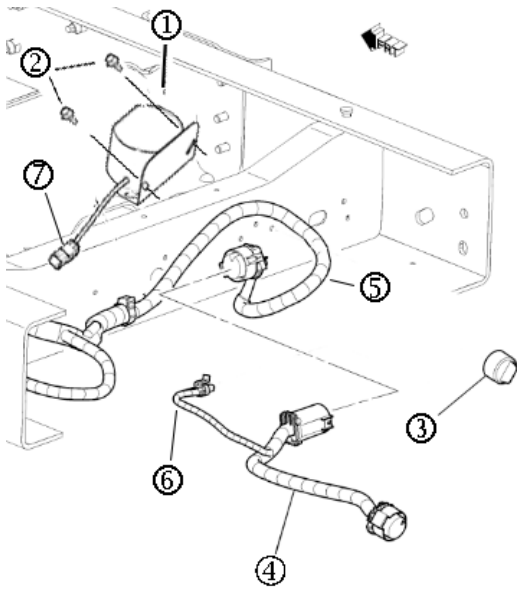

4195331

5. Connect the vehicle harness (5) to the long 7 pin male terminal plug on the 25922469 jumper harness (4).

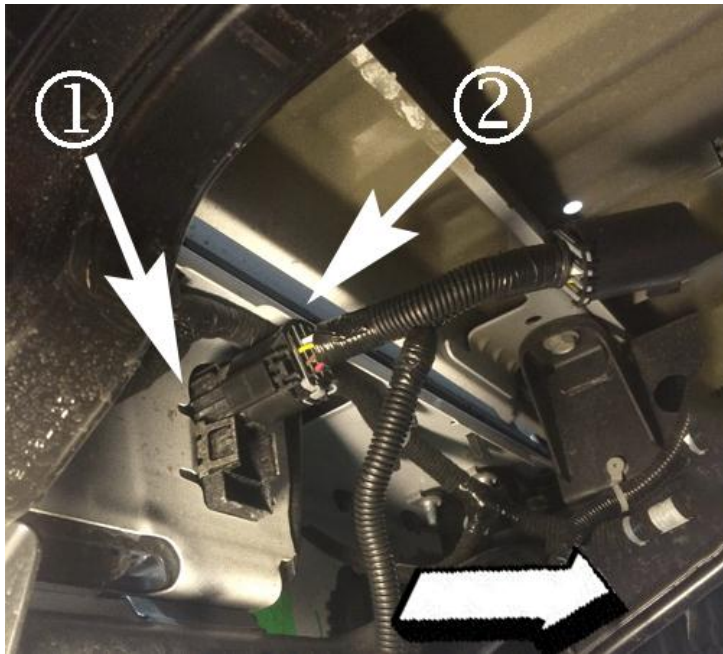

4195329

6. Insert the short 7 pin female terminal plug (2) into the backside of the trailer wiring connector (1) at the rear of the bumper.

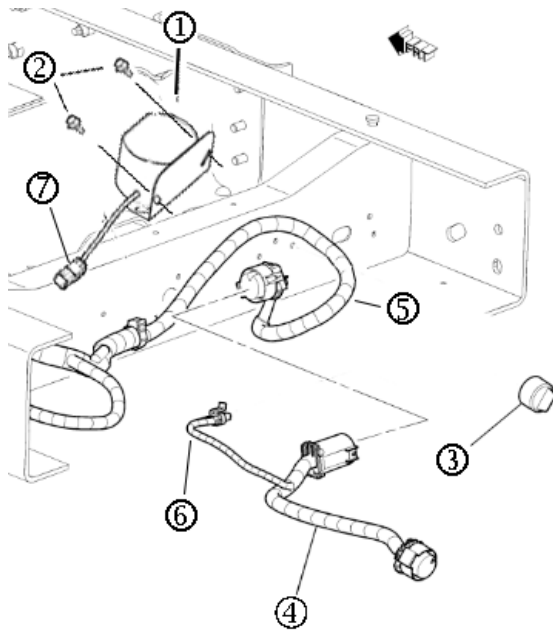

4195331

7. Install the backup alarm (1) to the existing holes of the rear frame crossmember with the mounting nuts and bolts (2). The crossmember mounting location is the forward face, near the leaf spring mid-point. The alarm speaker must be pointing down.
8. Connect the rear harness connector (6) to the alarm harness (7).
9. Tie strap the complete alarm harness to the existing wiring harness, securing it every 3 inches.
10. Lower the vehicle.
11. Connect the negative battery cable. Refer to *Battery Negative Cable Disconnection and Connection* in SI.
12. Turn the ignition to ON/RUN, and place gear selector into REVERSE to engage the backup alarm.
13. Raise the vehicle and install the spare tire. Refer to *Spare Wheel Carrier Hanger Replacement (Pickup)* in SI.

COURTESY TRANSPORTATION – For US and Canada

The General Motors Courtesy Transportation program is intended to minimize customer inconvenience when a vehicle requires a repair that is covered by the New Vehicle Limited Warranties. The availability of courtesy transportation to customers whose vehicles are within the warranty coverage period and involved in a product program is very important in maintaining customer satisfaction. Dealers are to ensure that these customers understand that shuttle service or some other form of courtesy transportation is available and will be provided at no charge. Dealers should refer to the General Motors Service Policies and Procedures Manual for Courtesy Transportation guidelines.

WARRANTY TRANSACTION INFORMATION

Submit a transaction using the table below. All transactions should be submitted as a ZFAT transaction type, unless noted otherwise.

Labor Code	Description	Labor Time	Net Item
9101577	Install Backup Alarm and Harness W/Z82	0.8	N/A
9101578	Install Backup Alarm and Harness WO/Z82	1.1	N/A
9101579	Reimbursement for Omitted Back-Up Alarm (Not for dealer use)	0.2	N/A

CUSTOMER NOTIFICATION – For US and Canada

General Motors will notify customers of this program on their vehicle. (see copy of customer letter included with this bulletin).

CUSTOMER NOTIFICATION – For Export

Letters will be sent to known owners of record located within areas covered by the US National Traffic and Motor Vehicle Safety Act. For owners outside these areas, dealers should notify customers using the attached sample letter.

DEALER PROGRAM RESPONSIBILITY

All unsold new vehicles in dealers' possession and subject to this program must be held and inspected/repaired per the service procedure of this program bulletin before customers take possession of these vehicles.

Dealers are to service all vehicles subject to this program at no charge to customers, regardless of mileage, age of vehicle, or ownership, through June 30, 2017. Customers who have recently purchased vehicles sold from your vehicle inventory, and for which there is no customer information indicated on the involved vehicle listing, are to be contacted by the dealer. Arrangements are to be made to make the required correction according to the instructions contained in this bulletin. A copy of the customer letter is provided in this bulletin for your use in contacting customers. Program follow-up cards should not be used for this purpose, since the customer may not as yet have received the notification letter.

In summary, whenever a vehicle subject to this program enters your vehicle inventory, or is in your facility for service through June 30, 2017 you must take the steps necessary to be sure the program correction has been made before selling or releasing the vehicle.



June 2015

This notice applies to your vehicle, **VIN:** _____

Dear General Motors Customer:

We have learned that your 2015 model year Chevrolet Colorado or GMC Canyon model vehicle may have a condition in which the backup alarm module was not installed to the vehicle during assembly.

Your satisfaction with your vehicle is very important to us, so we are announcing a program to correct this condition.

What We Will Do: Your GM dealer will install the backup alarm module. This service will be performed for you at **no charge until June 30, 2017**. After that, any applicable warranty will apply.

What You Should Do: To limit any possible inconvenience, we recommend that you contact your dealer as soon as possible to schedule an appointment for this repair. By scheduling an appointment, your dealer can ensure that the necessary parts will be available on your scheduled appointment date.

If you have any questions or concerns that your dealer is unable to resolve, please contact the appropriate Customer Assistance Center at the number listed below.

Division	Number	Text Telephones (TTY)
Chevrolet	1-800-222-1020	1-800-833-2438
GMC	1-800-462-8782	1-888-889-2438
Guam	65-6267-1752	
Puerto Rico – English	1-800-496-9992	
Puerto Rico – Español	1-800-496-9993	
Virgin Islands	1-800-496-9994	

We sincerely regret any inconvenience or concern that this situation may cause you. We want you to know that we will do our best, throughout your ownership experience, to ensure that your GM vehicle provides you many miles of enjoyable driving.

Alicia S. Boler-Davis
Sr. Vice President
Global Connected Customer Experience

GM CUSTOMER CARE AND AFTERSALES
DCS3679
URGENT - DISTRIBUTE IMMEDIATELY

Date: June 11, 2015

Subject: 15182 - Customer Satisfaction Program
Backup Alarm Not Installed On Vehicle

Models: 2015 Chevrolet Colorado
2015 GMC Canyon
Equipped with SEO 8S3

To: All Chevrolet and GMC Dealers

Attention: General Manager, Service Advisor, Service Manager, Parts and
Service Director, Parts Manager, New Vehicle Sales Manager,
and Warranty Administrator

General Motors is releasing Customer Satisfaction Program 15182 today. The total number of U.S. vehicles involved is 4. An initial supply of parts required to complete this recall was pre-shipped to the four involved dealers of record. This pre-shipment began June 9, 2015. Pre-shipped parts will be charged to dealer's open parts account.

Please see the attached bulletin for details.

Customer Letter Mailing

The customer letter mailing will begin June 25, 2015.

Global Connect (GWM)

The "Investigate Vehicle History" (IVH) screen was updated June 10, 2015

Campaign Initiation Detail Report (CIDR)

The CIDR will be available June 16, 2015.

END OF MESSAGE

GM CUSTOMER CARE AND AFTERSALES