

REFERENCE:	Nova Bus Manuals
SECTION:	12: Interior Furnishings
RS N°:	MQR 7621-849
EFFECTIVE IN PROD.:	N/A

APPLICATION DEADLINE: 2017JA22  
CLAIM REFERENCE NUMBER: WB-3448

SUBJECT:	Bum rest shells replacement
JUSTIFICATION:	Bum rest shells cracking and anchor points may loosen with time and vibration.

LEVEL	DESCRIPTION	DIRECT CHARGES		TIME
		LABOUR	MATERIAL	
1	Bushing added to prevent torquing of bolt directly on the shell.	Nova Bus	Nova Bus	1 h
2	–	–	–	–

**MATERIAL**

QTY	PART N°	REV.	DESCRIPTION	REPLACES PART N°
<b>LEVEL 1</b>				
1	N81705	–	SHELL REAR (CUT OUT)	N58090
1	N81704	–	SHELL FRONT (CUT OUT)	N74699
8	N31991	–	UPPER BOLT PAD M6 X 50 SS GR.A2 DIN 931	–
1	N35535-01	–	SIKAFLEX 552 AEROGRAY DARK/400	–
7	N81726	–	SCREW M12X75 HEX SS CL A2-70	–
7	N8902765	–	BUSHINGS	–
7	N79659	–	WASHER NORD-LOCK M12 O/S OD SS	–
<b>LEVEL 2</b>				
–	–	–	–	–

Materials will be available within 50 days. To order, please contact Prevost Parts by phone at 1-800-771-6682, by fax at 1-888-668-2555 or by email at prevostparts.commandes@volvo.com. Specify document number, quantity of parts required and shipping address.

**DISPOSAL OF PARTS**

REMOVED PARTS ARE:	DISCARDED *	RETAINED	* Dispose of the unused parts and the defective parts in accordance with local environmental standards in effect.
	Yes	–	

**REVISION HISTORY**

REV.	DATE	CHANGE DESCRIPTION	WRITTEN BY
NR	2015DEC02	Initial release	André Pelletier

CLIENT	ORDER	ROAD NUMBER		VIN (2NVY/4RKY...)		QTY
		FROM	TO	FROM	TO	
Clemson Area Transit - South Carolina	L769	—	—	S92U1D4 [REDACTED]	S92U1D4 [REDACTED]	1
CT Transit - Connecticut	L814	1462	1473	S92LXE4 [REDACTED]	S92L4E4 [REDACTED]	12

**WARNING**

Follow your internal safety procedures.

**PROCEDURE**

- 1.1. Remove the front and the rear bum rest shells. Retain the removed parts. See Figure 1.

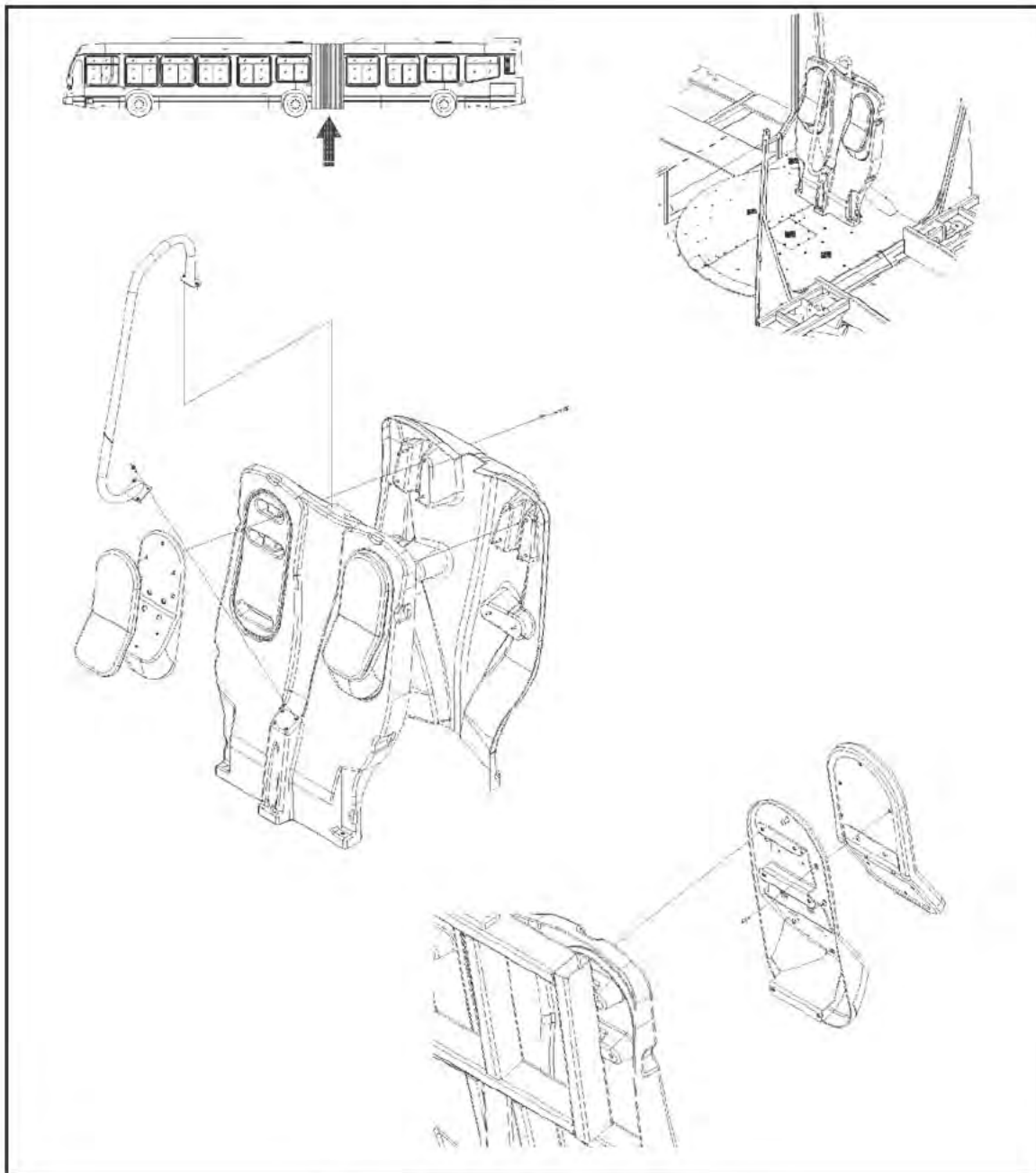

Figure 1 - Front and Rear Bum Rest Views

- 1.2. Install the new bum rest shells using the new bushing N8902765, self-locking washer N79659 and screw N81726. Torque to 30.2 lb-ft (41 N•m). See Figure 2. Typical for 7 locations.

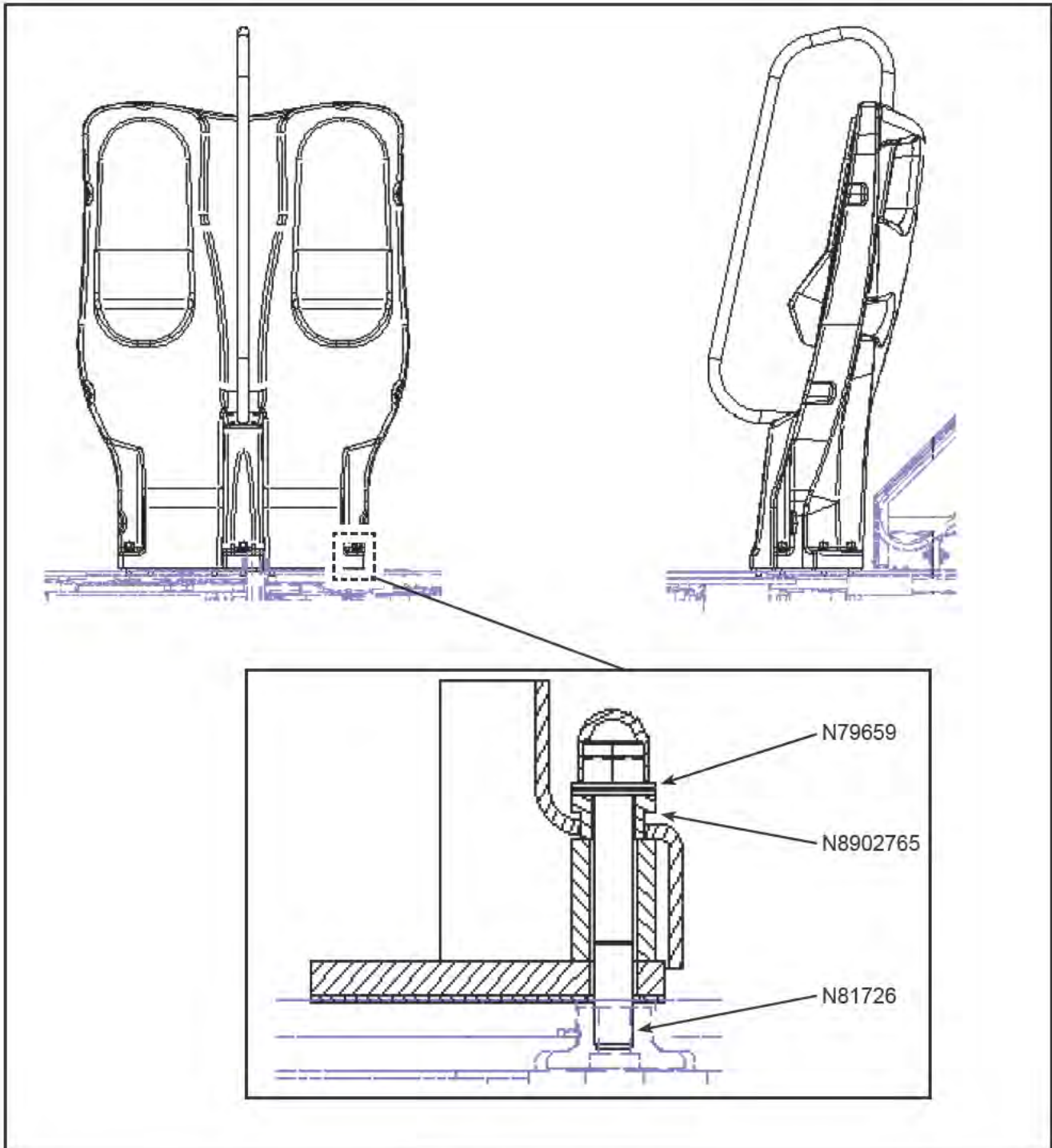

Figure 2 - Hardware Location

- 1.3. Re-install bum rest parts and hardware. New upper pad bolts N31991 are provided.
- 1.4. Apply Sikaflex N35535-01 to make a finishing seam between the rear and the front shell. ❖