



	Date	Group	No.	Release	Page
The Field Service Bulletin replaces bulletin FSB 221-010 dated 9.2013.	8.2015	221	010	03	1(7)

Diagnostic Trouble Codes (DTCs), Low Oil Pressure
CXU, GU, LEU, MRU
MP7 US2010, OBD2013, US2014, OBD2015

FSB 221-010, Diagnostic Trouble Codes (DTCs), Low Oil Pressure

(August 2015)

Information

During long hard pull conditions, diagnostic trouble codes (DTC) SPN 100 FMI 1 or P052400 can log, or engine shut down may occur on certain high mileage MACK CXU, GU, LEU and MRU vehicles built between January 1, 2010 and April 2, 2015 with MP7 engines. These DTC may occur during the conditions described in this bulletin, with or without an engine shut down lamp.

If there are no obvious signs of oil dilution, replace the pressure reduction valve, oil cooler and piston cooling nozzles using the procedure below. Also reprogram the engine control module if required based on the table below.

Note: Drain all engine oil into a clean container for reuse. Do not reuse engine oil if it is not reusable or the engine is due for normal oil change service.

Required Parts

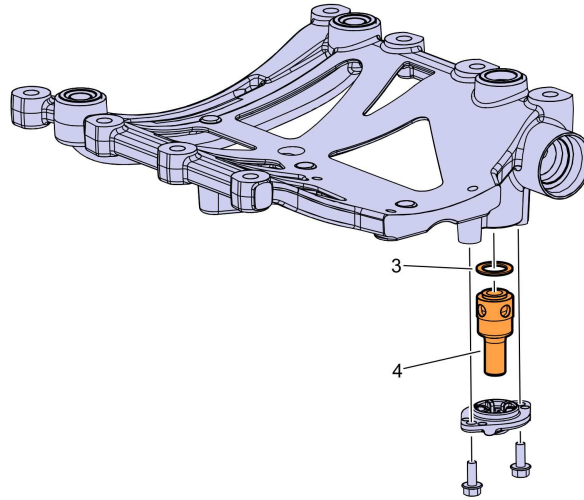

W2084376

Item Number	Part Number	Description	Quantity
3	469846	O-Ring, Internal	1
4	22416685	Pressure Reduction (Relief) Valve, Purple	1

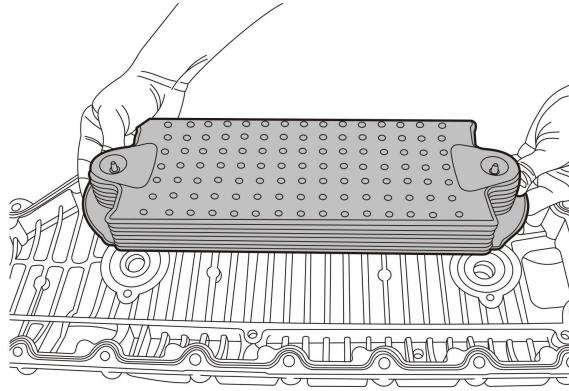

W2006072

Part Number	Description	Quantity
85125094	Oil Cooler Kit	1
993664	O-Ring (substitute for 471626 in oil cooler kit)	1
85116577	Turbocharger Installation Kit	1
85124530	EGR Cooler Kit	1

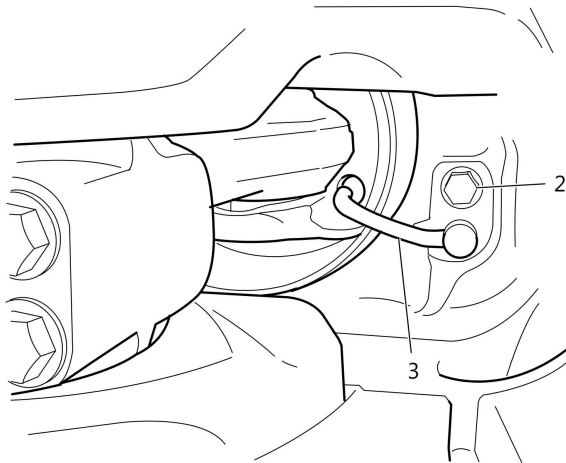

W2103580

Item Number	Part Number	Description	Quantity
2	994445	M8*16 Piston Cooling Nozzle Screws	6
3	22577447	Piston Cooling Nozzle	6

Check Engine Control Module Software Level

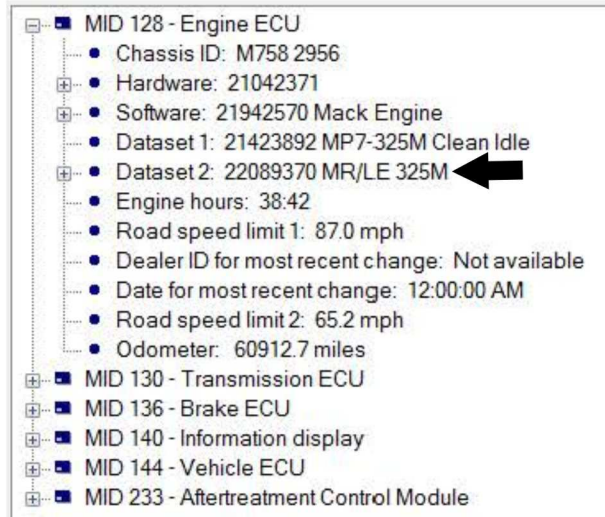

W2103598

US2010 and US2010 + 6 Control Unit Information

Data Set 2	US2010, January 1, 2010 to May 8, 2011	22494237 or less	Proceed with software update
		22709801 or higher	Open an eService and report the issue
	US2010 + 6, May 9, 2011 to December 31, 2012 (Includes LEU and MRU)	22488261 or less	Proceed with software update
		22711499 or higher	Open an eService and report the issue

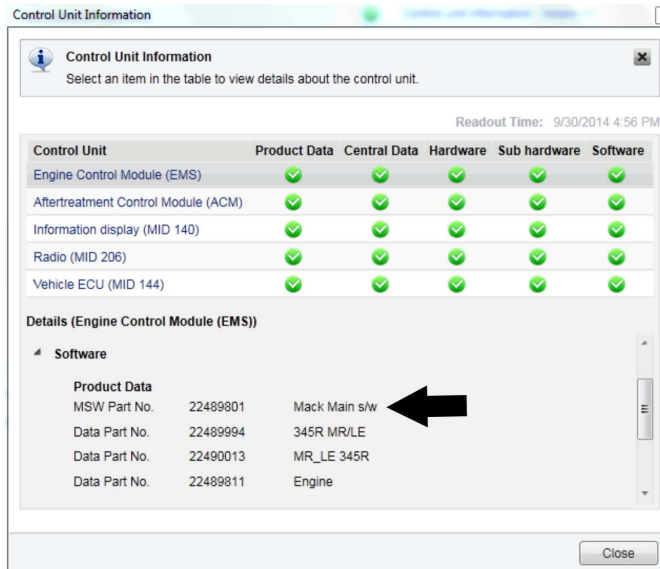

W2102733

OBD 2013, US2014 (GHG) and OBD2015 Control Unit Information

Main Software Part Number	OBD 2013, January 1, 2013 to December 31, 2013	22578181 or less	Proceed with software update
		22672847 or higher	Open an eService and report the issue
	US2014 (GHG), January 1, 2014 to December 31, 2014	22572319 or less	Proceed with software update
		22665162 or higher	Open an eService and report the issue
	OBD2015, January 1, 2015 to March 24, 2015	22616343 or less	Proceed with software update
		22644017 or higher	Open an eService and report the issue

Procedure

You must read and understand the precautions and guidelines in Service Information, Function Group 20, "Engine Safety Practices" before performing this procedure. If you are not properly trained and certified in this procedure, ask your supervisor for training before you perform it.

DANGER

Do not attempt to repair or service this vehicle without having sufficient training, the correct service literature and the proper tools. Failure to follow this could make the vehicle unsafe and lead to serious personal injury or death.

- 1 Secure the vehicle for service by parking it on a flat level surface, applying the parking brake, chocking the rear wheels, and placing the transmission in neutral or park.
- 2 Disconnect all battery cables from the negative (ground) battery terminals to prevent personal injury from electrical shock and prevent damage to electrical components.
- 3 Remove the oil pan. Refer to Function Group 21.
- 4 Remove and replace the pressure reduction (relief) valve in the oil valve body and replace the internal O-ring. Tighten cover fasteners to 10 ± 2 Nm (88 ± 17 in-lbs).

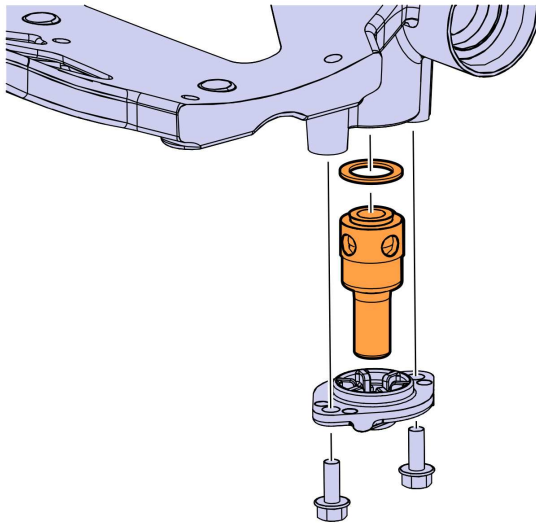

W2082023

Note: Make sure the valve is fully seated and the cover close to the valve housing prior to threading in the retaining screws. Otherwise the valve can make contact with the edge just ahead of the seating surface and damage the valve. Do not use power tools to install this valve. Do **NOT** disturb the pressure reduction valve located in the oil filter housing.

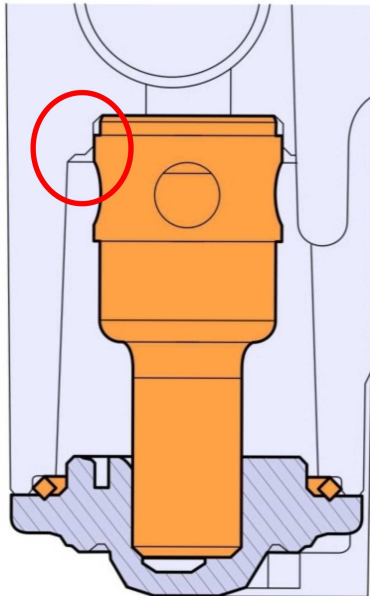

W2102180

- 5 Remove and replace the piston cooling nozzles. Refer to Function Group 22. Replace the single use screws. Tighten the new screws to 24 ± 3 Nm (18 ± 2 ft-lb).
- 6 Remove and replace the oil cooler. Refer to Function Group 223.
- 7 Install the oil pan. Refer to Function Group 21.
- 8 Refill the engine oil to the proper level.
- 9 Reconnect all previously removed cables to the negative (ground) battery terminals.
- 10 Reprogram the engine control module if required based on the reference table. Refer to Function Group 28.
- 11 Start engine, check for leaks and proper operation. Clear any DTC.

Reimbursement

This repair may be eligible for reimbursement if a product failure was experienced within time and mileage limits of the applicable Warranty coverage. Reimbursement is obtained via the normal claim handling process.

MACK Trucks reserves the right to make any changes in design or to make additions to or upon its products without incurring any obligations to install the same on vehicles previously built.