

ATTENTION:
 GENERAL MANAGER
 PARTS MANAGER
 CLAIMS PERSONNEL
 SERVICE MANAGER

IMPORTANT - All Service Personnel Should Read and Initial in the boxes provided, right.

© 2015 Subaru of America, Inc. All rights reserved.



QUALITY DRIVEN® SERVICE

SERVICE INFORMATION

APPLICABILITY: 2010-14MY Legacy and Outback **NUMBER:** 12-178-15
SUBJECT: Hood Latch and Striker Mounting Bolt Change **DATE:** 01-30-15

INTRODUCTION

This Service Information bulletin announces a change to the appearance of the hood latch and striker mounting bolts. The original bolts had a black-colored finish while the new bolts are silver in color. There is no change to the shape or strength of the bolts.

COUNTERMEASURE IN PRODUCTION:

The new silver-colored bolts were incorporated into production during February, 2014 starting with the following VINS:

- Legacy: **E*029476**
- Outback: **E*293637**

PART INFORMATION:

Bolt Color **BLACK** p.n. **901000332**

Bolt Color **SILVER** p.n. **901000407**



SERVICE PROCEDURE / INFORMATION

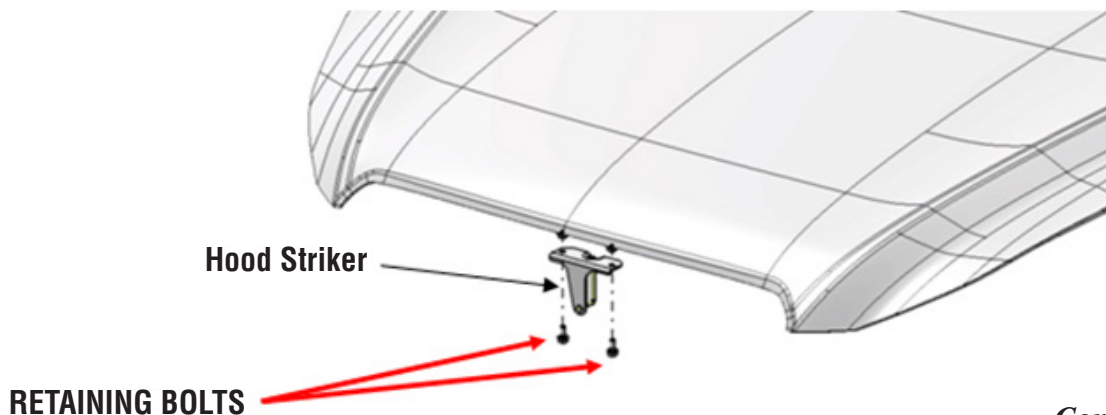

Continued...

CAUTION: VEHICLE SERVICING PERFORMED BY UNTRAINED PERSONS COULD RESULT IN SERIOUS INJURY TO THOSE PERSONS OR TO OTHERS.

Subaru Service Bulletins are intended for use by professional technicians ONLY. They are written to inform those technicians of conditions that may occur in some vehicles, or to provide information that could assist in the proper servicing of the vehicle. Properly trained technicians have the equipment, tools, safety instructions, and know-how to do the job correctly and safely. If a condition is described, DO NOT assume that this Service Bulletin applies to your vehicle, or that your vehicle will have that condition.

SUBARU OF AMERICA, INC. IS ISO 14001 COMPLIANT

ISO 14001 is the international standard for excellence in Environmental Management Systems. Please recycle or dispose of automotive products in a manner that is friendly to our environment and in accordance with all local, state and federal laws and regulations.

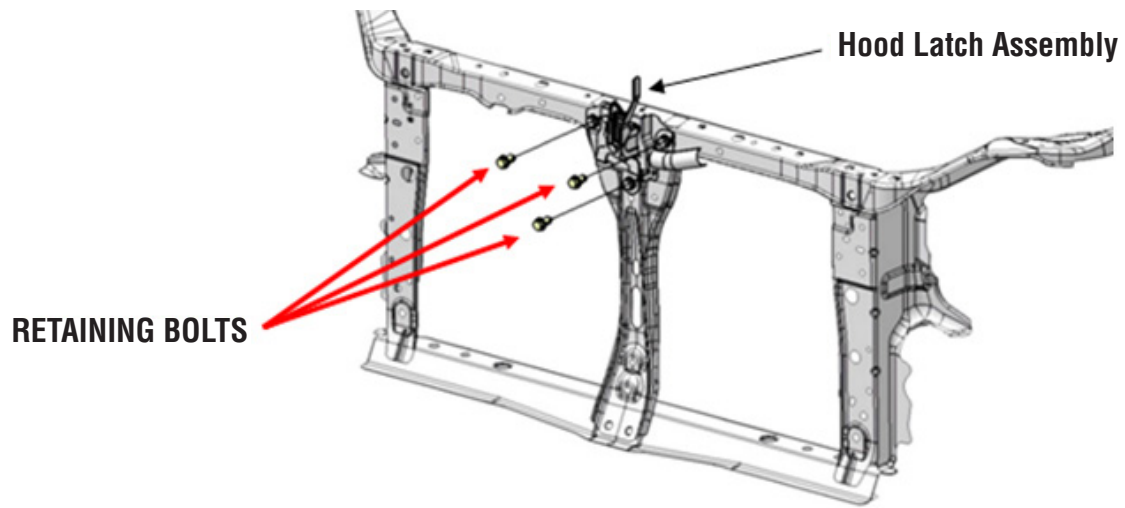

- When replacing any of these bolts, replace with the same part number as originally installed.
- The hood latch and striker bolts are the same. Do not mix new and old on the same vehicle.

The torque specifications are also unchanged:

- Hood Latch bolts (3): torque to 24.3 ft. lbs
- Hood Striker bolts (2): torque to 18.4 ft. lbs.

REMINDER: SOA strongly discourages the printing and/or local storage of service information as previously released information and electronic publications may be updated at any time.

- **Always refer to STIS for the latest service information before performing any repairs.**