

PREVOST

**WARRANTY
BULLETIN**

WB15-10

DATE :	APRIL 2015	SECTION :	01 - Engine
EXPIRATION:	APRIL 2017		
SUBJECT :	ENGINE OIL FLEXIBLE TUBE INSPECTION AND REPLACEMENT		

APPLICATION

NOTICE TO SERVICE CENTERS	
<i>Verify vehicle eligibility by checking warranty bulletin status with SAP or via ONLINE WARRANTY SYSTEM available on Service / Warranty tab of Prevost website.</i>	
Model	VIN 
H3-41, H3-45 coaches Model Year : 2014 - 2015	From 2PCH33494 <u>EC712595</u> up to 2PCH33494 <u>FC712890</u> incl.
H3-45 VIP motorhomes Model Year : 2014 – 2015	From 2PCVS3491 <u>EC712608</u> up to 2PCVS3499 <u>FC712888</u> incl.
X3-45 coaches Model Year : 2014- 2015	From 2PCG33499 <u>EC735611</u> up to 2PCG33492 <u>FC735841</u> incl.
X3-45 VIP commercial use Model Year : 2014 - 2015	From 2PCCS3492 <u>EC735614</u> up to 2PCCS3494 <u>FC735812</u> incl.
X3-45 VIP motorhomes Model Year : 2015	The following individual vehicles : 2PCBS3490 <u>FC735740</u> , 2PCBS3495 <u>FC735779</u> , 2PCBS3498 <u>FC735789</u> , 2PCBS3499 <u>FC735798</u> , 2PCBS3498 <u>FC735808</u> , 2PCBS3497 <u>FC735816</u> , 2PCBS3490 <u>FC735818</u>
This bulletin does not necessarily apply to all the above-mentioned vehicles, some vehicles may have been modified before delivery. The owners of the vehicles affected by this bulletin will be advised by a letter indicating the Vehicle Identification Number (VIN) of each vehicle concerned.	

DESCRIPTION

On the vehicles affected by this bulletin, inspect the lower oil fill tube flexible tube. If it is made of black material (EDPM), replace tube. Green and blue silicone hoses are accepted.

MATERIAL

Order the following parts:

Part No.	Description	Qty
012933	HOSE SILICONE POLYESTER	1

NOTE

Material can be obtained through regular channels.

PROCEDURE



DANGER

Park vehicle safely, apply parking brake, stop engine and set battery master switch(es) to the OFF position prior to working on the vehicle.

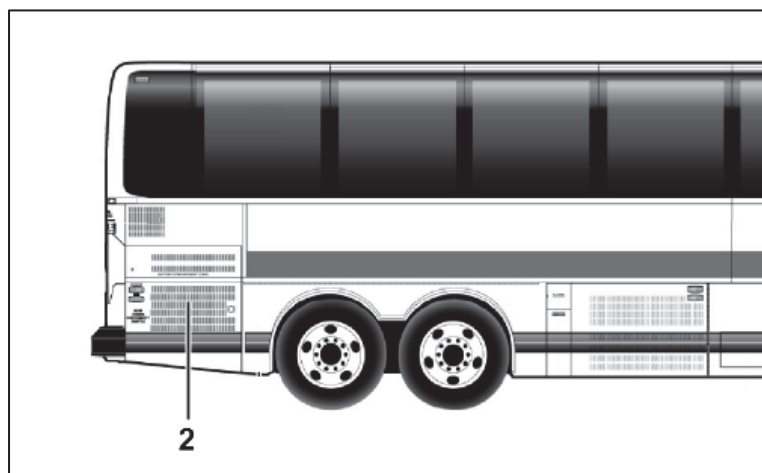

Figure 1

A: Inspection

- A. Open curb side engine compartment door. (Item 2, Fig. 1)
- B. Visually inspect the lowest section of the oil fill tube. (Fig. 2) The hose connecting the steel tube to the oil pan should be green or blue. (Fig 3 & 4)
- C. If hose is black, perform replacement according to Step **B** below. Otherwise, this is the end of the bulletin.

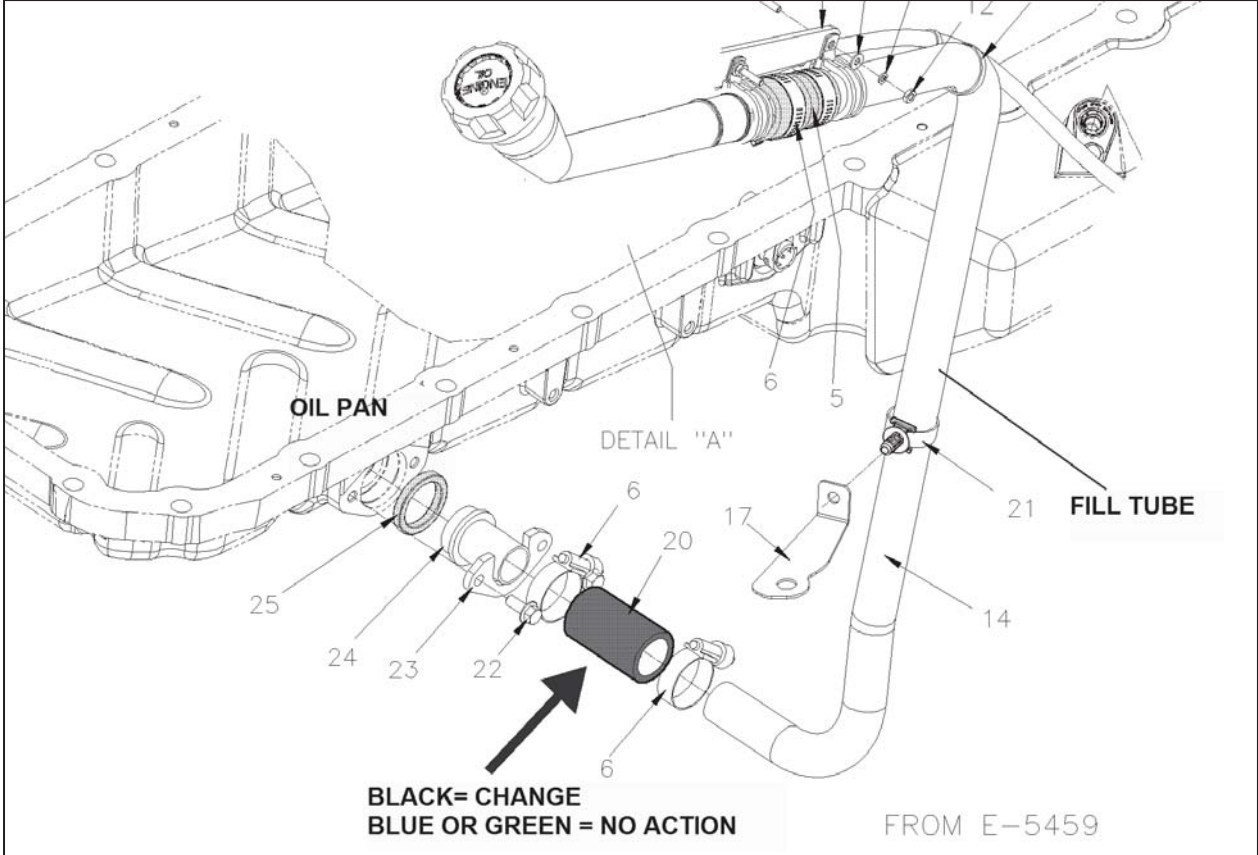

Figure 2

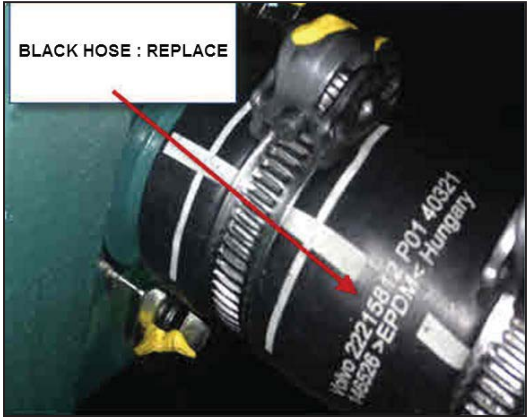

Figure 3



Figure 4

B: Replacement instructions

- 1) Apply parking brake and block front wheels.(Fig. 5)

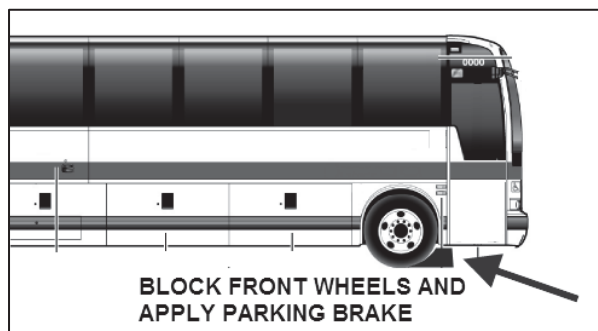

Figure 5

- 2) Using two mobile column lifts, jack vehicle about 38 cm (15 in) by drive axle to allow oil to move to the forward section of the oil pan.
- 3) Use a suitable container to collect any remaining oil that may drip while performing replacement.
- 4) Perform tube removal by undoing the two clamps. (Fig. 2) Dispose of tube according to regulations.
- 5) Install new tube 012933. Tighten clamps to 3,4 N-m (30 lbf-in).
- 6) Apply a torque seal of different color from the original seal to clearly mark change.
- 7) Lower vehicle. Confirm proper operation. Confirm installation is oil tight.

PARTS / WASTE DISPOSAL

DO NOT RETURN THE REPLACED PARTS. Discard waste according to applicable environmental regulations (Municipal/State[Prov.]/ Federal)

WARRANTY

This modification is covered by Prevest's normal warranty.

Step A, inspection only: we will reimburse you fifteen minutes (15 min) of labor. Or for **Steps A and B** we will reimburse you the parts and 3/4 of an hour (45 min) of labor, upon receipt of a warranty claim.

Please submit claim via our Online Warranty System, available at www.prevestcar.com (under Service \ Warranty section). Use Claim Type: "Bulletin/Recall" and select "Warranty Bulletin WB15-10".

OTHER

VBC Bulletin	N/A
Fail Code	01.00
Defect Code	09
Syst.Cond.	B
Causal Part	1136335

Access all our Service Bulletins on
<https://secureus5.volvo.com/technicalpublications/en/pub.asp>
or scan the QR-Code with your smart phone.

E-mail us at technicalpublications_prev@volvo.com and type
"ADD" in the subject to receive our warranty bulletins by e-mail.

