

This Service Program replaces PV729-SP366-003, "Front Radar, Failure (USA71403)" dated 08.2015.

Date 10.2015 Group **366** No. **003** Release **02** Page 1(25)

Front Radar, Failure
VN

SP 366-003, Front Radar, Failure

(October 2015)

Certain VOLVO VN trucks built between 11/11/2013 and 01/14/2015, equipped with front radar may experience loss of front object detection or erratic operation of cruise control functions. The terminal seals of the harness is allowing moisture and corrosion to build up in the front radar harness and/or radar antenna module. To ensure proper operation of the front radar, the harness is inspected for the proper seal and/or corrosion, and the module is inspected for signs of corrosion. If the harness, seal or module fail inspection, replacement of the harness and/or radar antenna is required. Follow the inspection and repair procedures outlined in this Service Program (SP).

If the truck is eligible for this repair, call 1-877-986-5862 and provide the following information: 17 digit Vehicle Identification Number (VIN), Product Improvement Number (SP366-003), Dealer Code, and the Purchase Order (PO) Information.

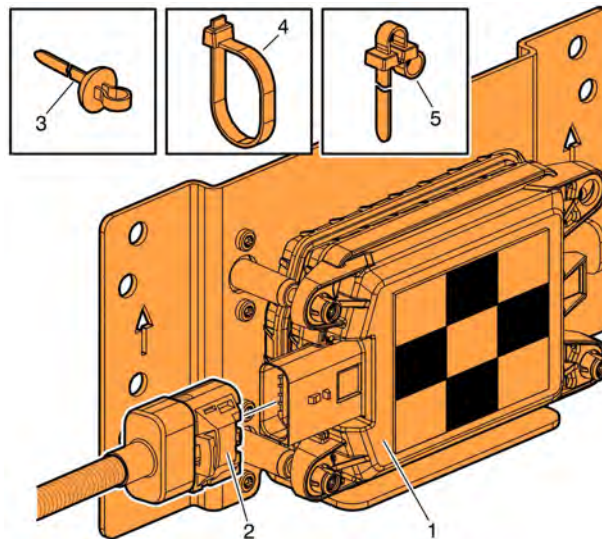

W3103446

Required Parts

Front Radar Replacement Parts			
Item	Description	Part Number	Qty
1	Sensor, Front Radar	85142824	1
2	Harness, Front Antenna	22638506	1
3	Clamp, Universal	25170732	2
4	Cable Tie	980464	9
5	Cable Tie	20395795	1

Decommissioning the Truck for Repair

You must read and understand the precautions and guidelines in Service Information, group 30, "General Safety Practices, Electrical" before performing this procedure. If you are not properly trained and certified in this procedure, ask your supervisor for training before you perform it.

NOTE: Information is subject to change without notice. Illustrations are used for reference only and can differ slightly from the actual vehicle being serviced. However, key components addressed in this information are represented as accurately as possible.

- 1 Park the vehicle on a flat and level surface.
- 2 Apply the parking brake.
- 3 Place the transmission in neutral or park.
- 4 Install the wheel chocks.

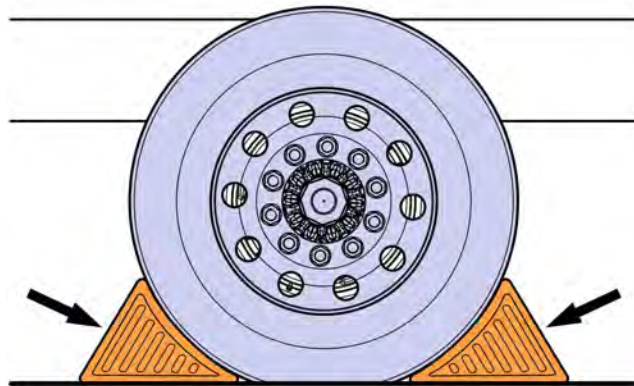

W7086748

5 Disconnect all of the cables from the battery's negative terminals.

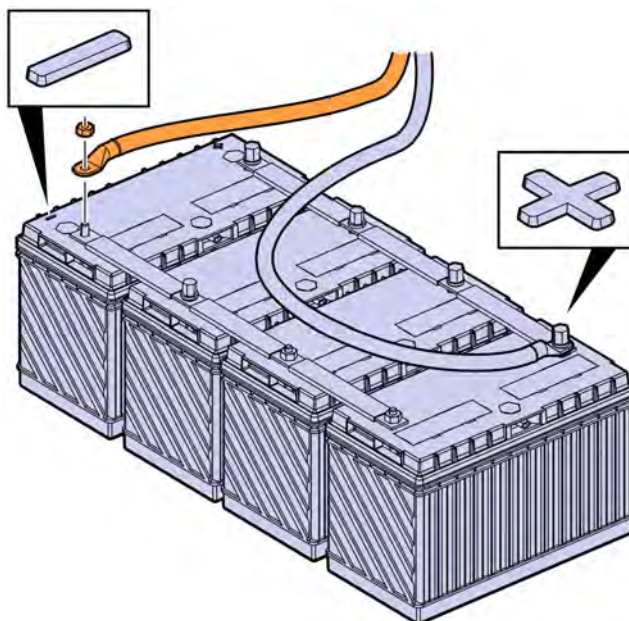

W3086747

Front Radar Inspection

1 Disconnect the radar connector.

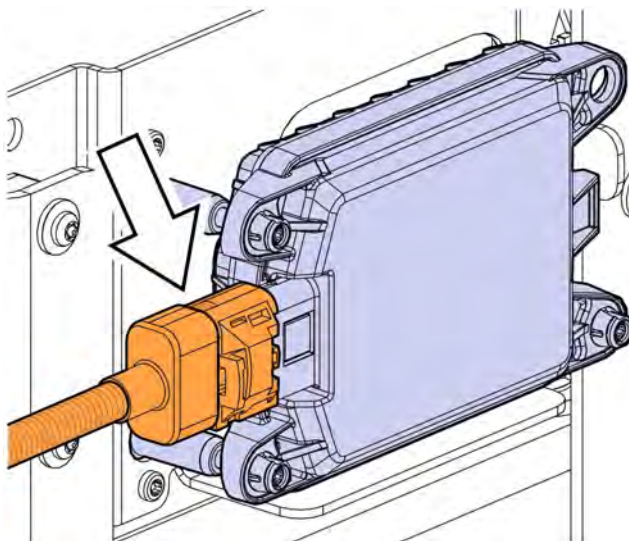

W3103447

- 2 Inspect the radar connector for water intrusion and corrosion on the terminal pins.

Note: If there are signs of water intrusion, corrosion of the harness and front radar module, continue to page 11 (**Front Radar and Harness Replacement**) section and follow the repair procedure.

- 3 Inspect the connector to determine if the proper seal was installed in the connector housing.

Note: If the color of the terminal seals are (**BLACK**) and no corrosion is present, connect the radar connector, and no further action is required. Continue to page 24, (**Commission the truck for Operation**), and follow steps 1 – 2.

Note: If the color of the terminal seals are (**YELLOW**), and no corrosion is present, continue to page 5, (**Front Radar Harness Replacement**) and replace the harness only.

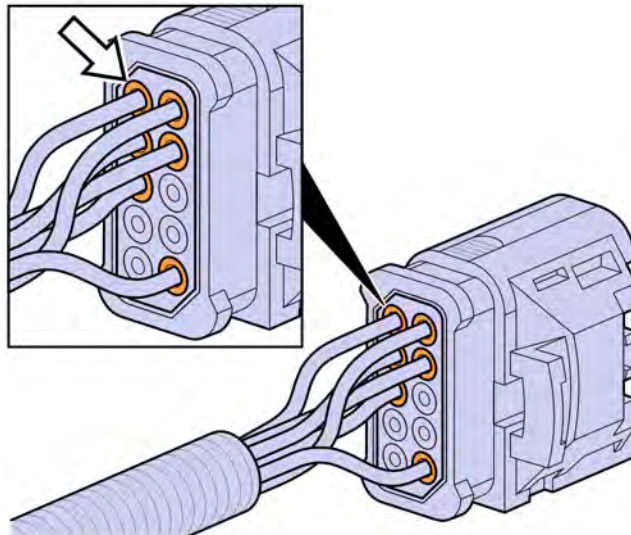

W3103448

Front Radar Harness Replacement

- 1 Remove the fasteners securing the grille.

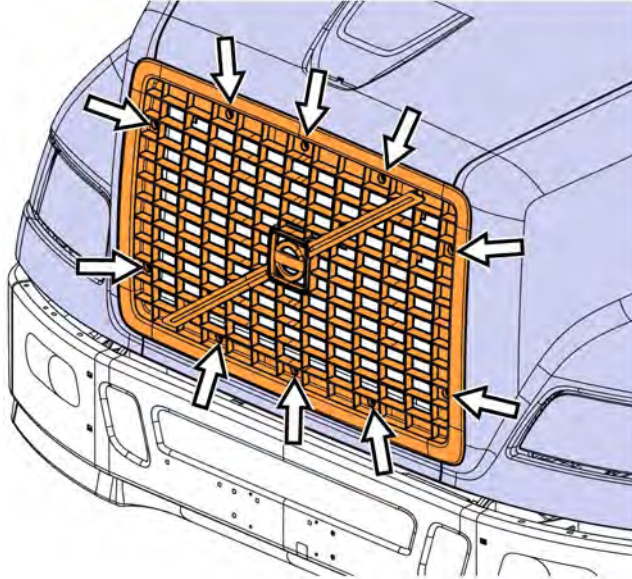

W2083544

- 2 Remove the grille.

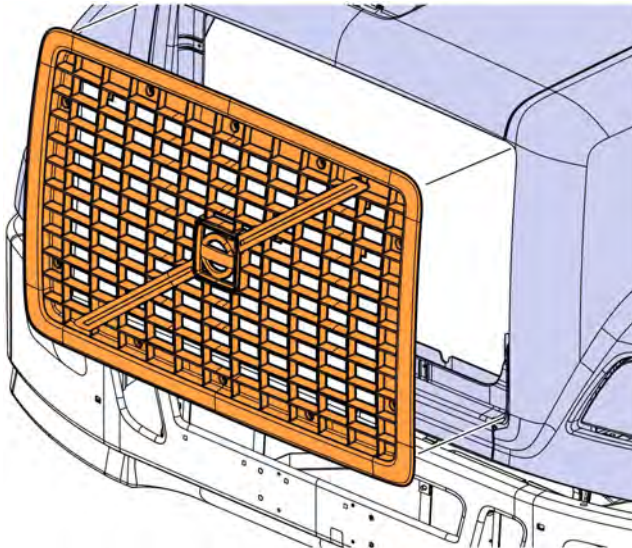

W2083545

3 Open the hood.

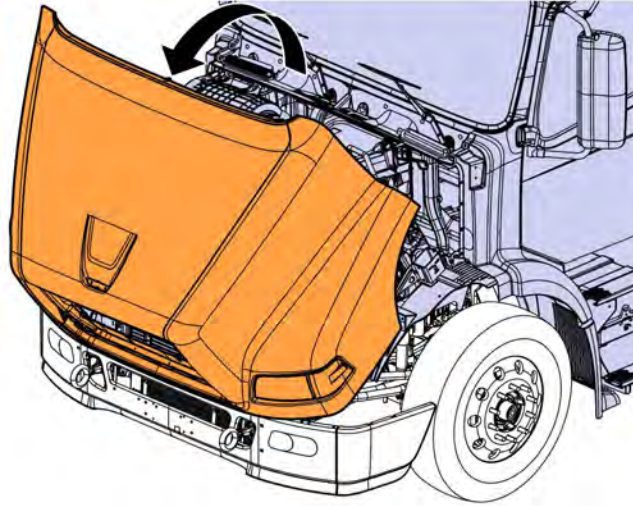

W8090036

4 Remove the cable ties securing the front radar harness.

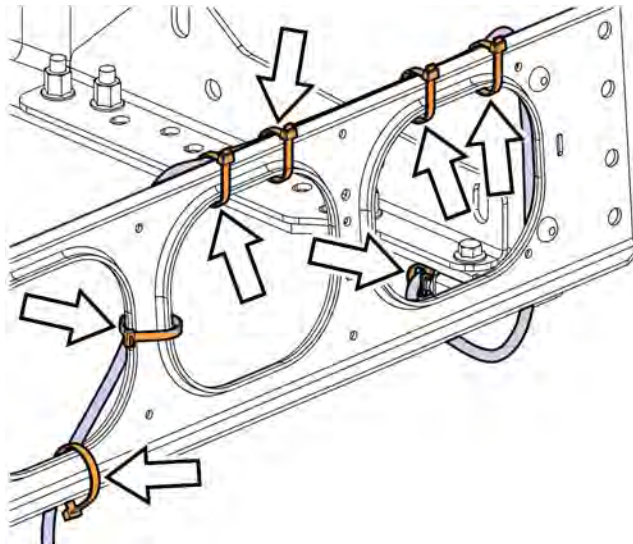

W3103449

- 5 Disconnect the front radar harness from the main cab harness at the front bumper end cap.

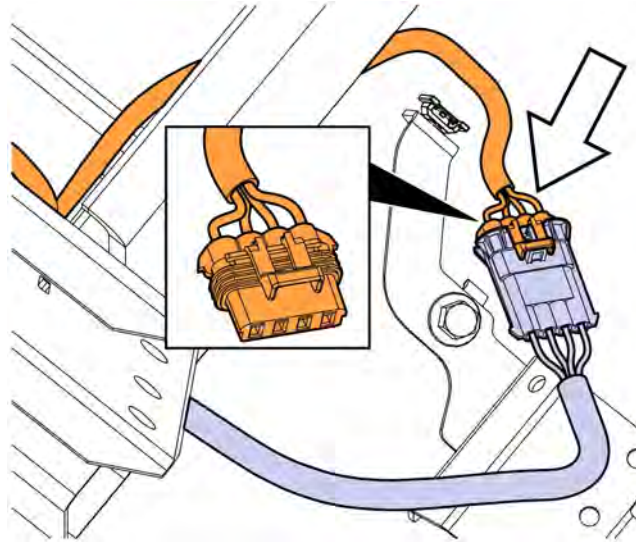

W3103450

- 6 Remove the existing front radar harness.

Note: Note the routing of the existing harness for installation of the replacement harness.

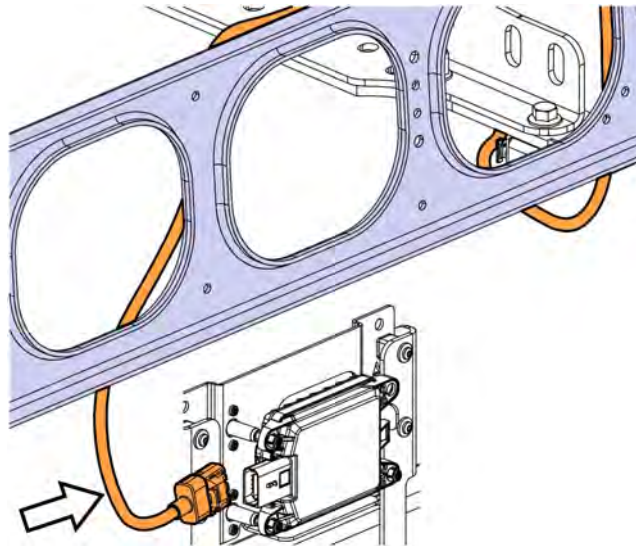

W3103451

- 7 Route the replacement front radar harness into position as shown.

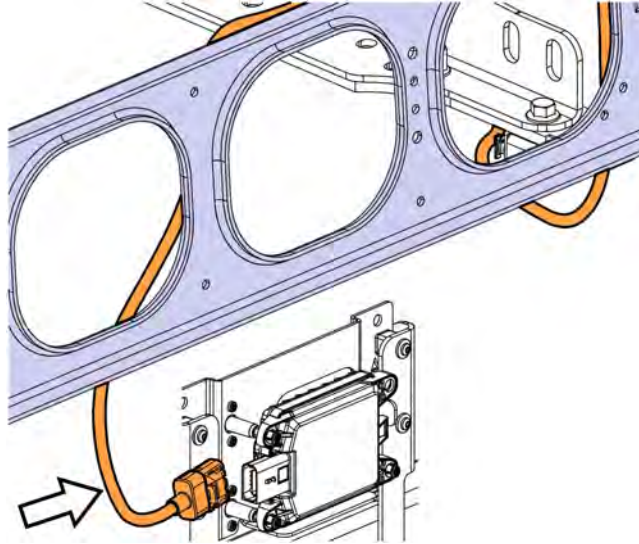

W3103451

- 8 Connect the replacement front radar harness to the main cab harness at the bumper end cap.

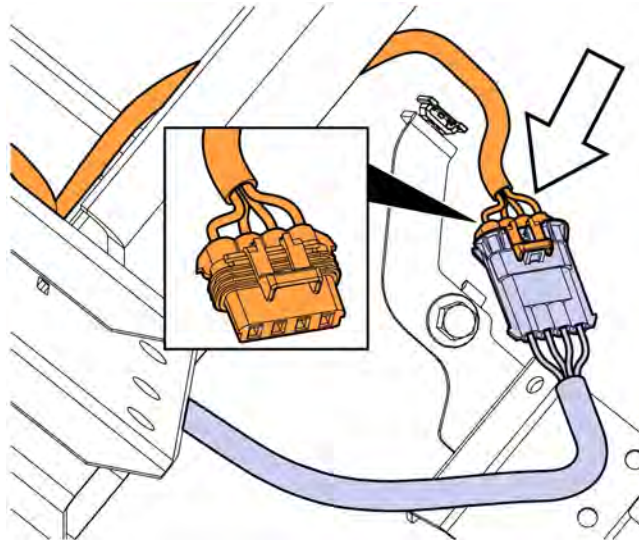

W3103450

9 Connect the front radar harness to the radar module.

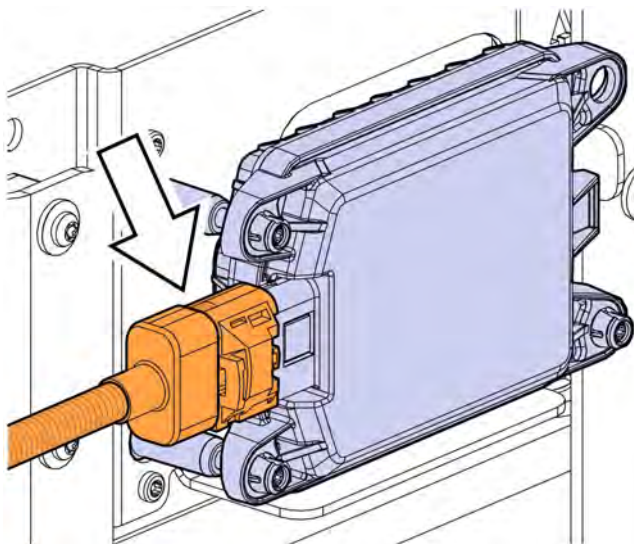

W3103447

10 Using cable ties, secure the front radar harness as shown.

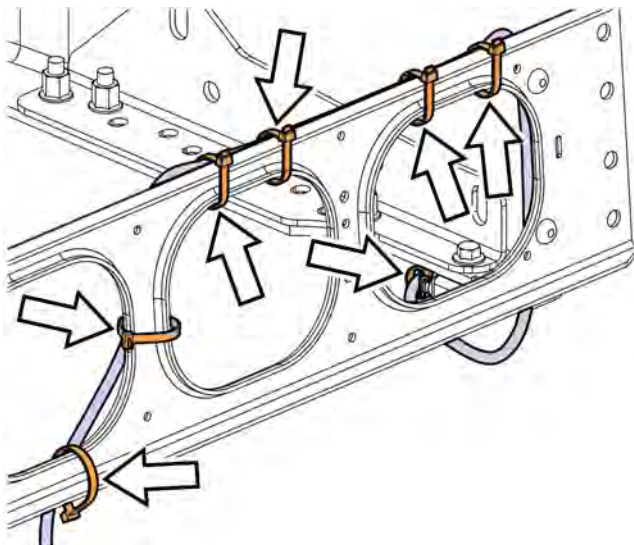

W3103449

11 Close the hood.

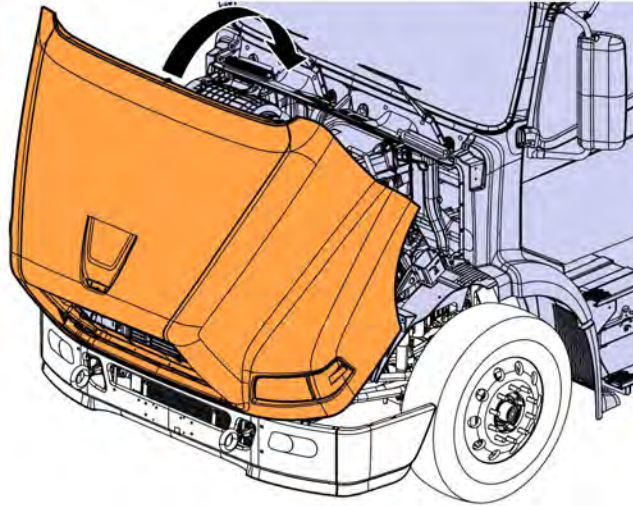

W8090037

12 Position the grille.

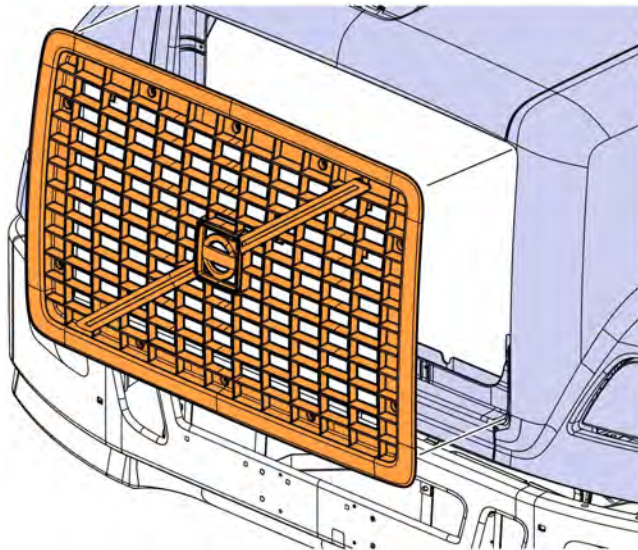

W2083545

13 Install the fasteners securing the grille.

14 Tighten the grille fasteners to 2 ± 0.3 Nm (17 ± 3 in-lb).

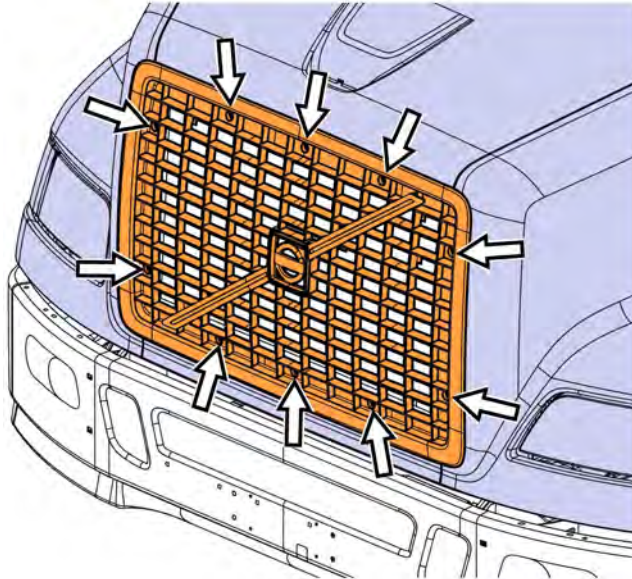

W2083544

15 Continue to page 15, and **(Commission the truck for Operation)**.

Front Radar and Harness Replacement

1 Remove the fasteners securing the radar assembly.

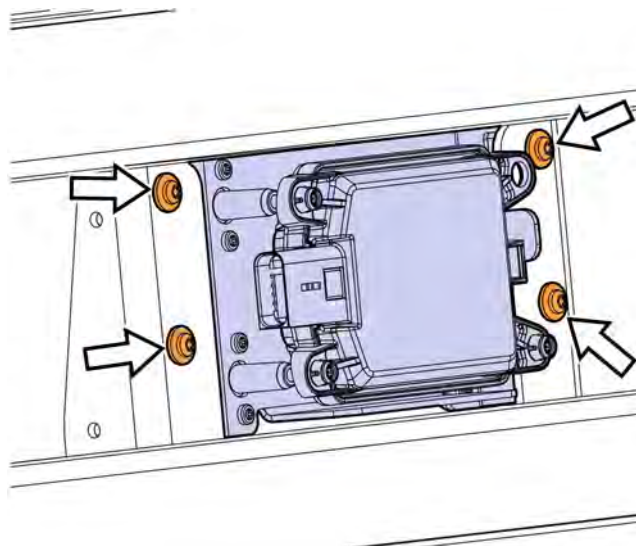

W3103452

2 Remove the radar sensor assembly.

Note: Return radar assembly to the Core Hub for credit and processing.

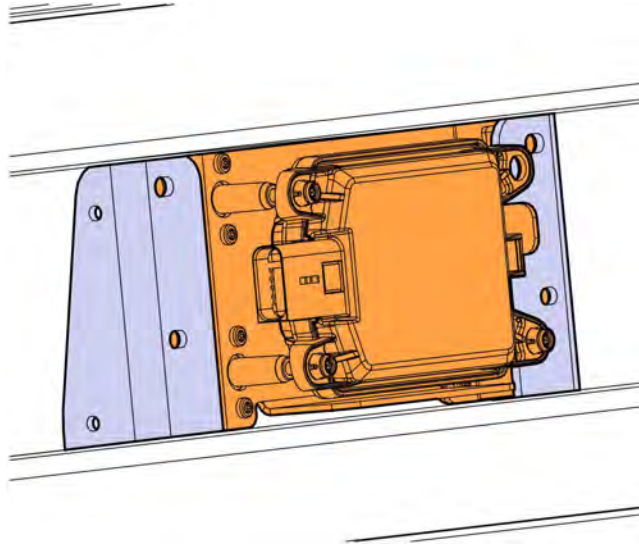

W3103453

3 Position the replacement radar assembly.

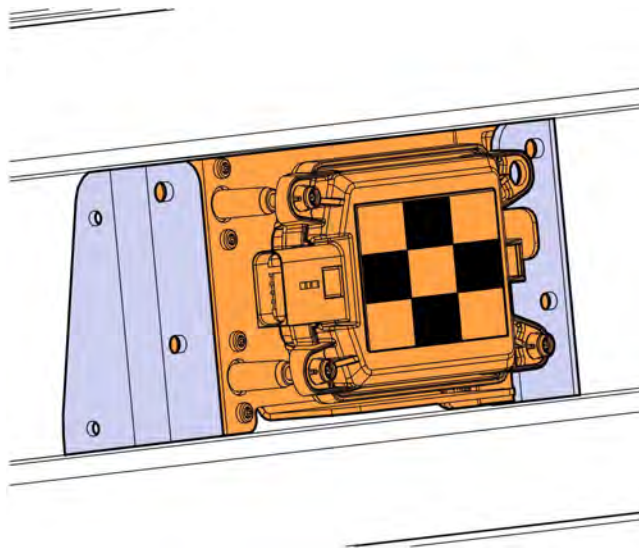

W3103454

- 4 Install the fasteners securing the front radar assembly.
- 5 Tighten the radar assembly fasteners to 2 ± 0.3 Nm (17 ± 3 in-lb).

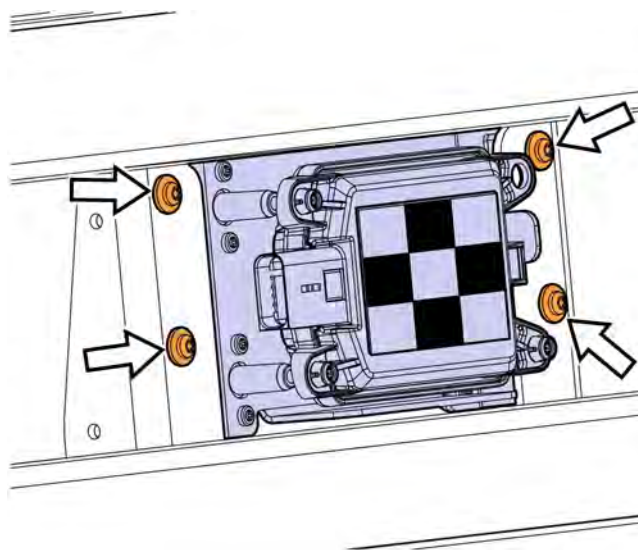

W3103455

- 6 Remove the fasteners securing the grille.

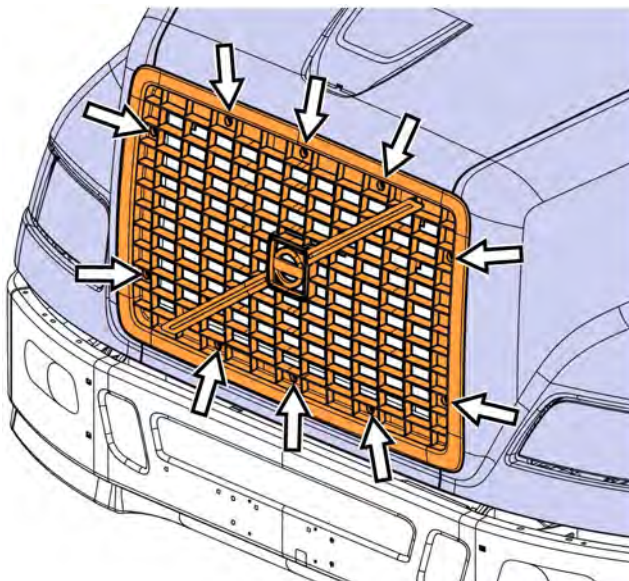

W2083544

7 Remove the grille.

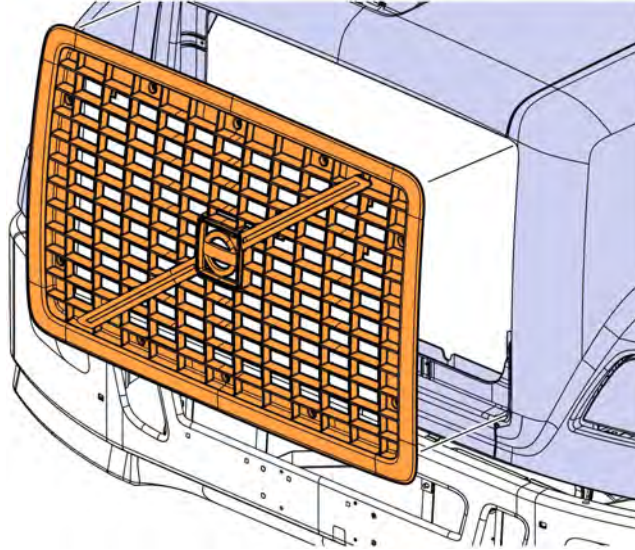

W2083545

8 Open the hood.

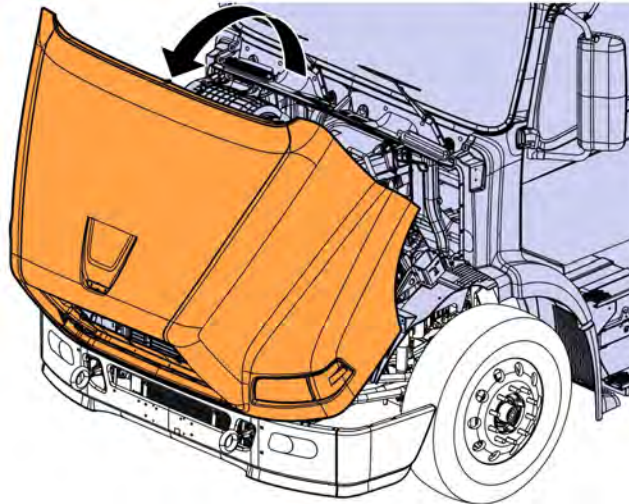

W8090036

9 Remove the cable ties securing the front radar harness.

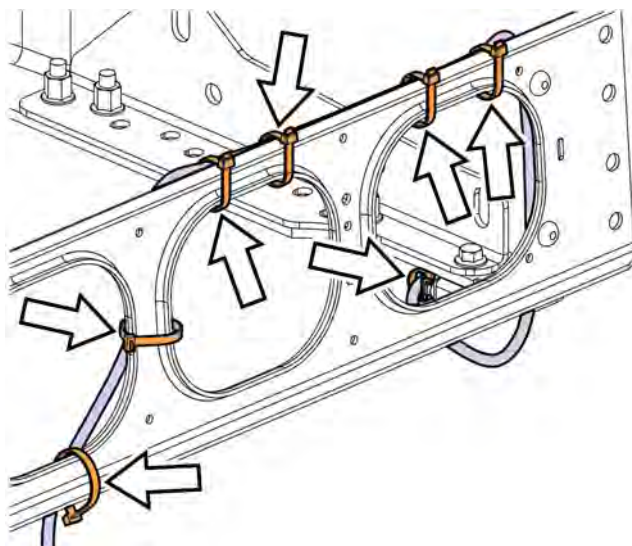

W3103449

10 Disconnect the front radar harness from the main cab harness at the front bumper end cap.

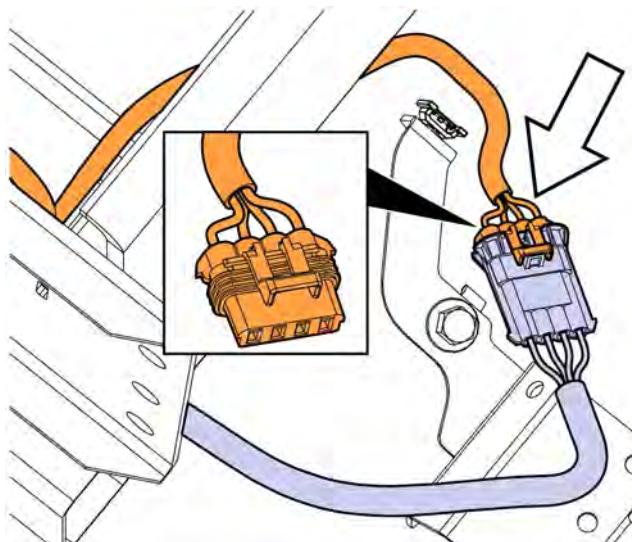

W3103450

11 Remove the existing front radar harness.

Note: Note the routing of the existing harness for installation of the replacement harness.

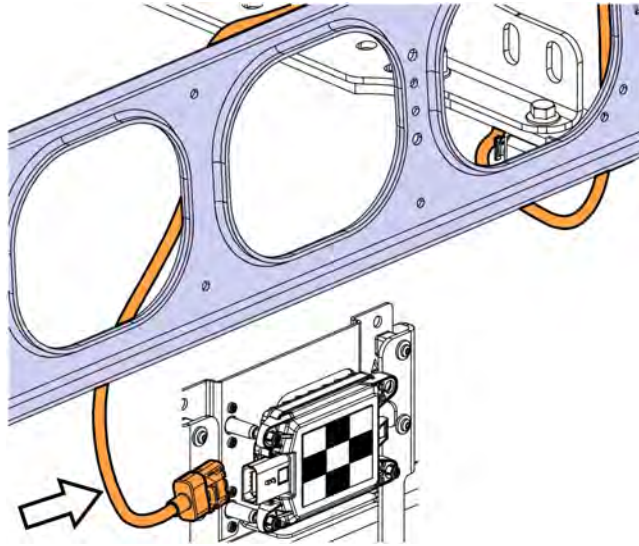

W3103463

12 Route the replacement front radar harness into position as shown.

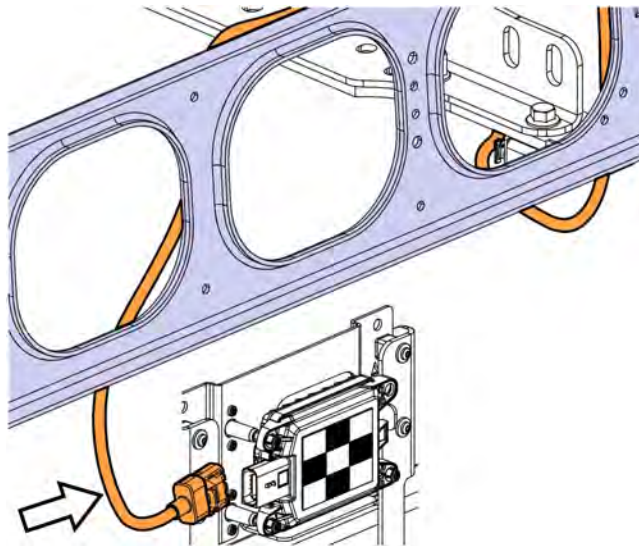

W3103463

13 Connect the replacement front radar harness to the main cab harness at the bumper end cap.

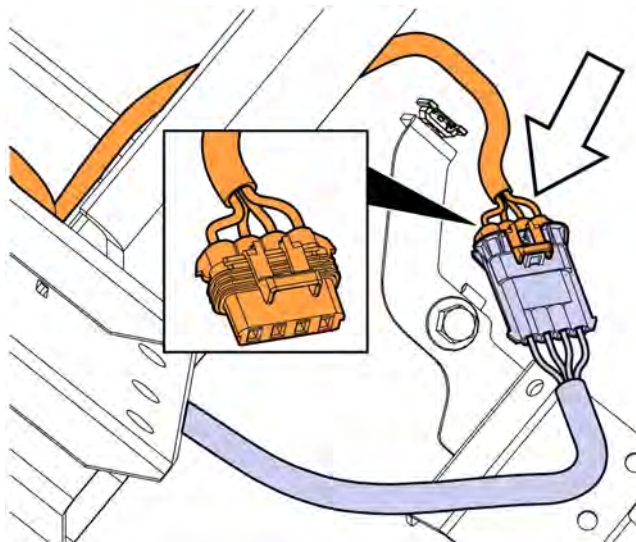

W3103450

14 Connect the front radar harness to the radar module.

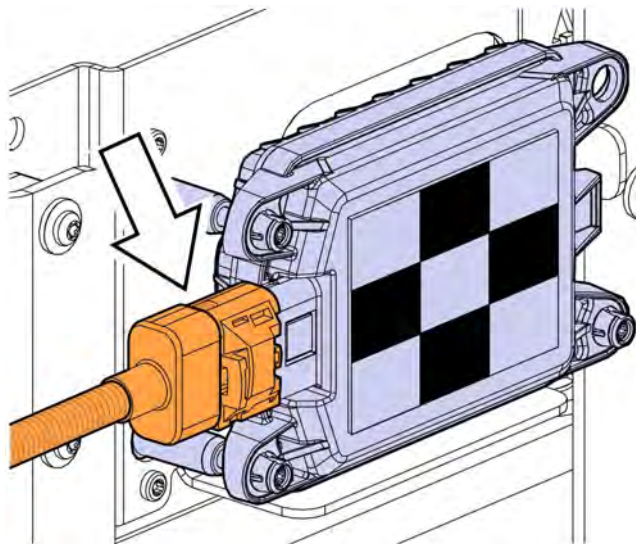

W3103462

15 Using cable ties, secure the front radar harness as shown.

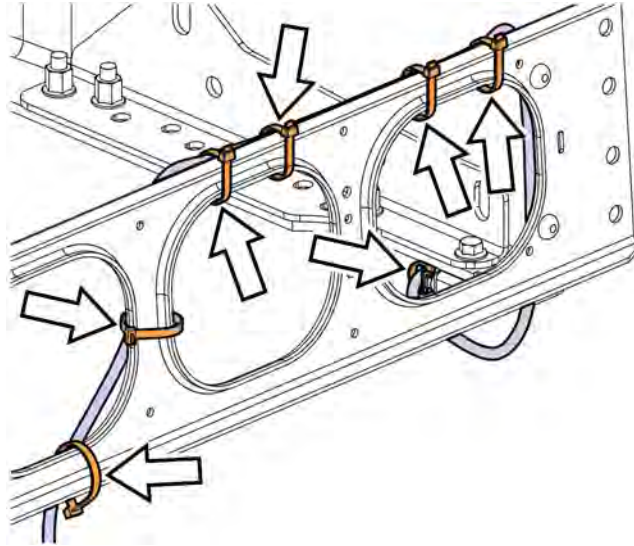

W3103449

16 Close the hood.

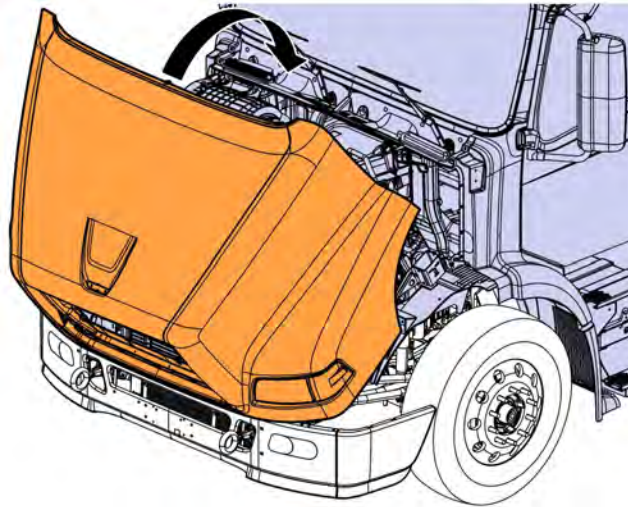

W8090037

17 Position the grille.

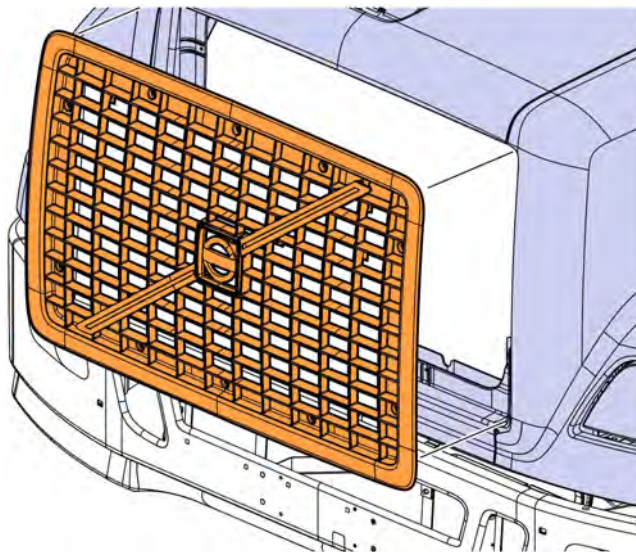

W2083545

18 Install the fasteners securing the grille.

19 Tighten the grille fasteners to 2 ± 0.3 Nm (17 ± 3 in-lb).

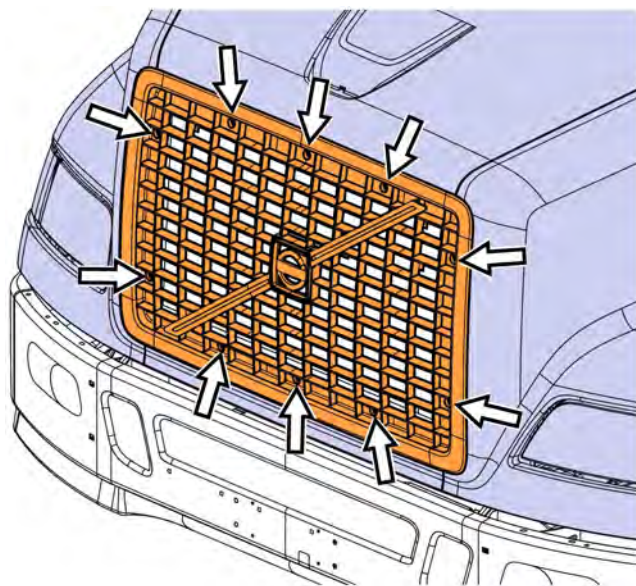

W2083544

20 Perform the Sensor, VOLVO Enhanced Cruise (VEC), Alignment Check and Adjustment procedure as shown in steps 21 – 31.

21 Place a digital angle gauge on top of the vehicle frame rail as shown. Reset the digital gauge to 0 degree.

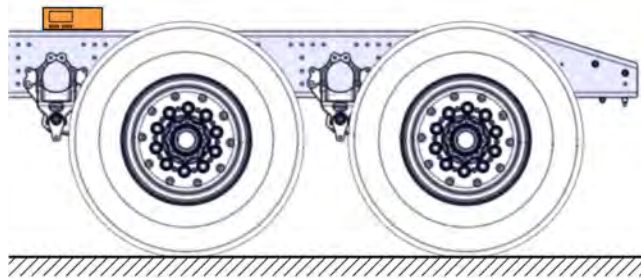

W8085795

22 Attach Bendix Alignment tool (part number K065284) to the front of the radar sensor cover.

Note: A cover (2) is included with the replacement radar sensor. If the cover is missing, use assistance to hold the alignment tool (1) on the radar sensor.

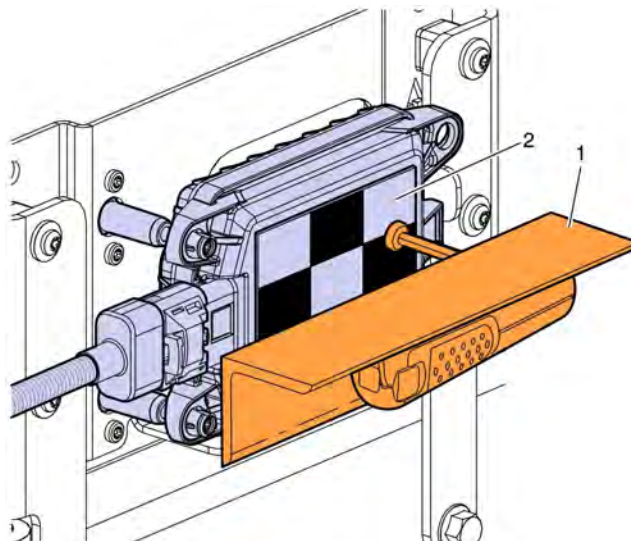

W3103456

23 Attach the digital angle gauge to the alignment tool.

24 Check the vertical alignment tool and ensure the digital angle gauge is reading 0 degrees.

Note: If the vertical alignment tool with the angle gauge is not reading 0 degrees, adjustment of the radar sensor's vertical angle is required.

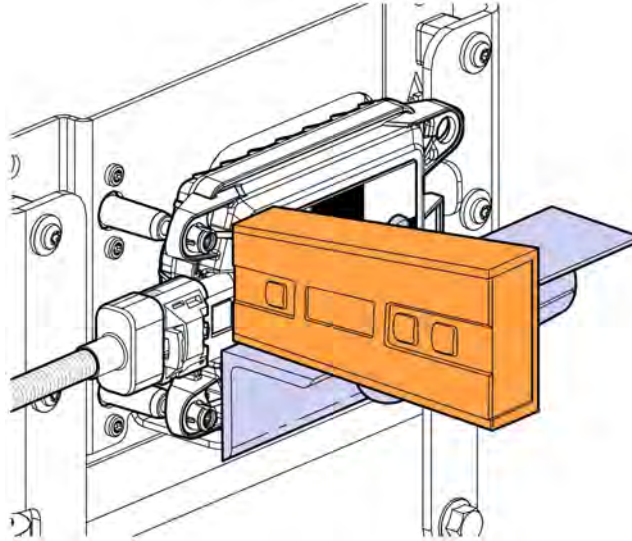

W3103457

25 If applicable, adjust the vertical alignment of the radar sensor to 0 degrees.

Note: Periodically recheck the alignment tool and angle gauge during the vertical alignment procedure.

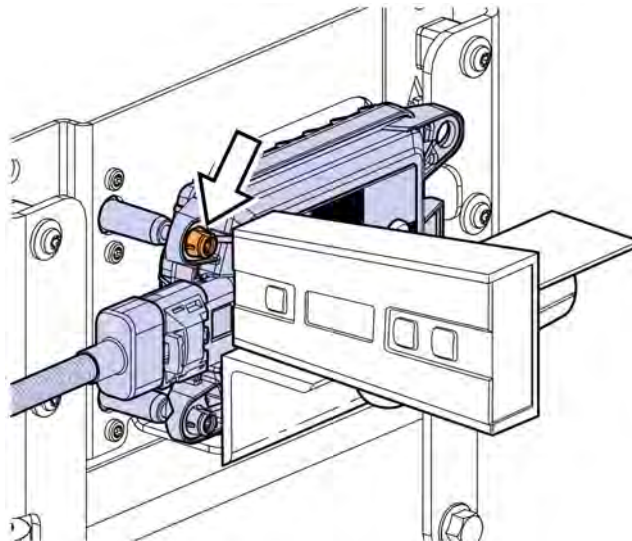

W3103458

26 Using the alignment tool. turn the laser on and check the sensor's lateral alignment.



CAUTION

Do not stare into the laser beam (2).

Note: Use the tow hook receptacles (1) or frame rail ends as a measuring point if possible.

27 After the first lateral measurement (3), turn the laser off.

28 Flip the laser and orient it towards the opposite side of the truck.

29 Turn the laser on, and record the second lateral measurement (3) from the tow hook receptacle (1).

Note: If the lateral measurements vary by more than 3 mm (0.125 in) of each other, adjust the lateral alignment of the radar sensor.

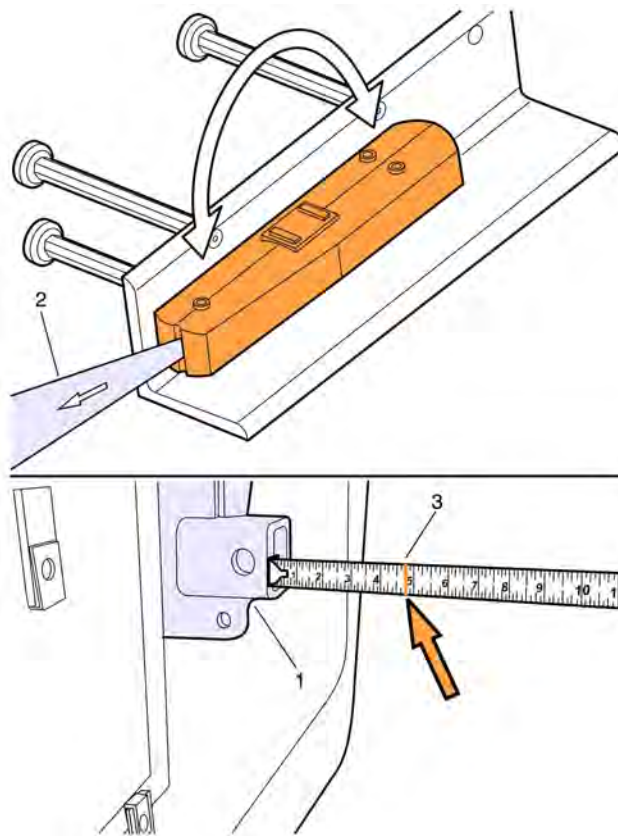

30 If applicable, adjust the lateral alignment of the radar sensor until the two measurements are (Less than 3 mm (.125 in) of each other).

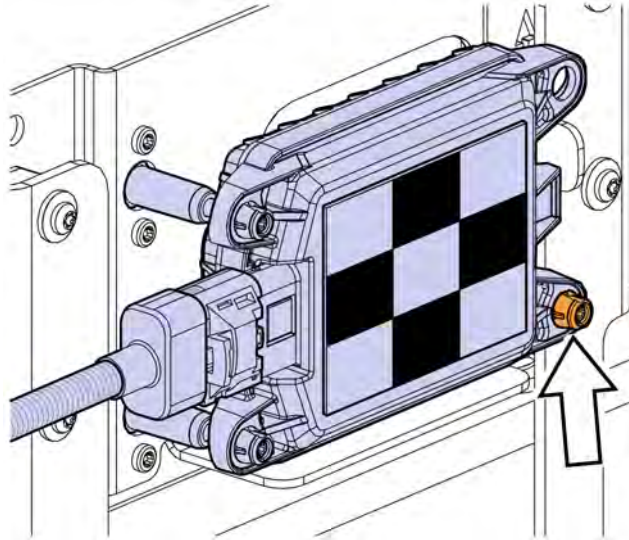

W3103460

31 If applicable, remove the cover from the front of the radar sensor.

Note: Failure to remove the cover will cause a Diagnostic Fault Code (DTC).

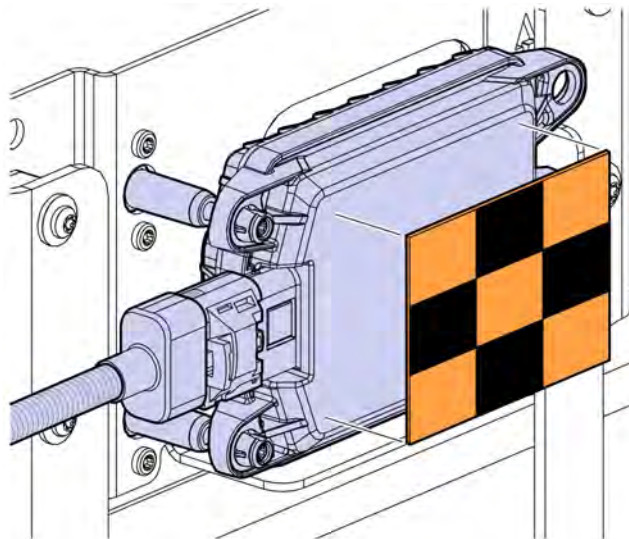

W3103461

32 Continue to page 24, and (**Commission the truck for Operation**).

Commissioning the Truck for Operation

- 1 Connect all of the cables to the battery's negative terminals.

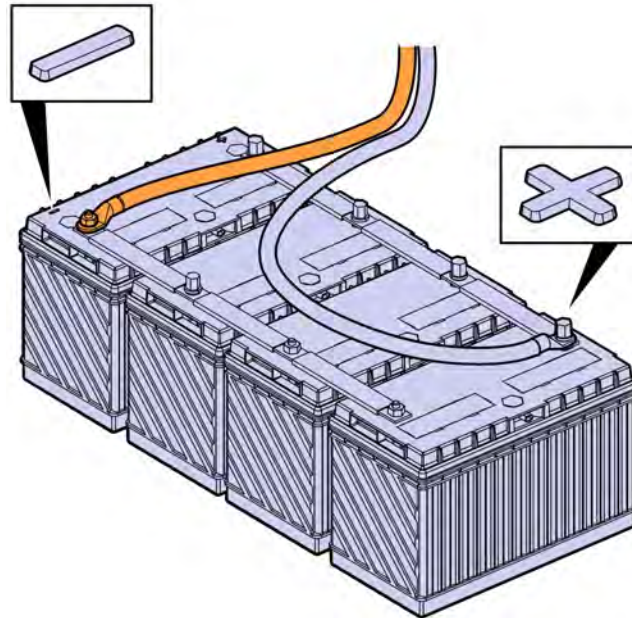

W3086758

- 2 Remove the wheel chocks.

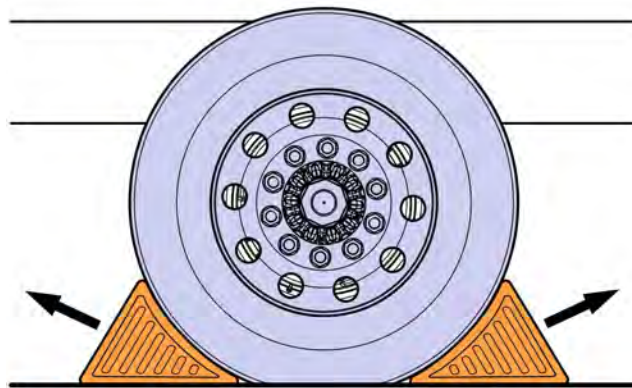

W7086759

- 3 Check the operation of the **(Adaptive Cruise Control)**.

Note: If a diagnostic trouble code (DTC) is logged after the repairs are complete, connected the truck to a PC with BENDIX A-Com software to clear the DTC.

- 4 Test drive the truck and check the operation of the adaptive cruise control.

Note: This is a separate operation.

Reimbursement

This repair is covered by an authorized Service Program. Reimbursement is obtained via the normal claim handling process.	UHP Reimbursement	eWarranty Reimbursement
Claim Type (used only when uploading from the Dealer Bus. Sys.)	B	B
Recall Status		
Vehicle inspected, repair not required		1- Inspected OK
Vehicle repaired per instruction		2- Modified per instruction
Labor Code		
Primary Labor Code (Front Radar Harness Inspection)	3000-06-09-01 0.3 hrs	36605-0-01 0.3 hrs
Labor Code (Front Radar Harness Replacement)	3665-03-09-02 1.1 hrs	36605-0-02 1.1 hrs
Labor Code (Front Radar and Harness Replacement)	3665-03-09-03 1.4 hrs	36605-0-03 1.4 hrs
Take to take charge and determine campaign status	1700-16-01-01 0.3 hrs	17003-0-01 0.3 hrs
Causal Part	22134349	22134349
SCC Code	S6932	NA
Authorization Number	NA	SP366-003
Expiration Date	30-AUG-2016	30-AUG-2016

Note: Take Charge Time is not included in the Labor Code for this operation. Take charge may be eligible but can only be used once per repair visit. If vehicle is having other warranty repairs performed, take charge should be charged to the warranty repair, otherwise take charge can be charged to this service program.