



SERVICE INFORMATION BULLETIN

Subject: COMMERCIAL FLEET CRADLE ENGINE MOUNT REINFORCEMENT

Models Affected: ALL 2011, 2012 AND 2014 MODEL YEAR VEHICLES

BACKGROUND

Some model MV-1 vehicles, typically operated under “Commercial Fleet” conditions, may experience over time excessive wear of the Left Engine Mount Plate. In cases where damage has resulted, a Suspension Cradle replacement may be necessary. For Engine Mount Plates exhibiting minor stress yield, and for preventative maintenance of undamaged plates, installation of the Cradle Engine Mount Reinforcement Kit is recommended.

WARRANTY

The provisions of the normal warranty policy apply. If installation is for preventative maintenance, the kit and installation time is paid by the customer.

INSTALLATION TIME

The recommended installation time is 1.0 hour. Labor operation 09M330.

PARTS

Kit PN SP002141 can be obtained through the Dealer Communications System (DCS). Order one kit per vehicle.

CRADLE ENGINE MOUNT REINFORCEMENT KIT PN SP002141

The following parts are included in kit SP002141:

ITEM	DESCRIPTION	PART NUMBER	QTY
1	Instructions	SPD000014	1
2	Bracket - Reinf Cradle Eng Mnt, LH	PT020491	1
3	Bolt, M8 X 1.25 X 20	PT006745	4
4	Nut - Hex M8 X 1.25	PT020473	4
5	Shim - Reinf Brkt Cradle Eng Mnt, 2.3mm	PT020504	1
6	Shim - Reinf Brkt Cradle Eng Mnt, 0.9mm	PT020505	2
7	Shim - Reinf Brkt Cradle Eng Mnt, 0.5mm	PT020506	1
8	Template - Reinf Brkt Cradle Eng Mnt, RR	PT020659	1
9	Template - Reinf Brkt Cradle Eng Mnt, FRT	PT020657	1
10	O-RING, Hose ASM, Rack to Cooler, Chassis Side	SP000626	1
11	O-RING, P/S Pressure Hose, Strg Rack Side of Hose	SP000630	1
12	O-RING, Backup, P/S Pr. Hose, Strg Rack Side of Hose	SP000629	1

PROCEDURE

1. Inspect the Engine Mount Plate and adjacent front and rear welded brackets under the left Engine Mount for damage or cracking. Verify suspected cracks with an appropriate dye kit. If multiple cracks are present, it is recommended to replace Suspension Cradle (See Figure 1).

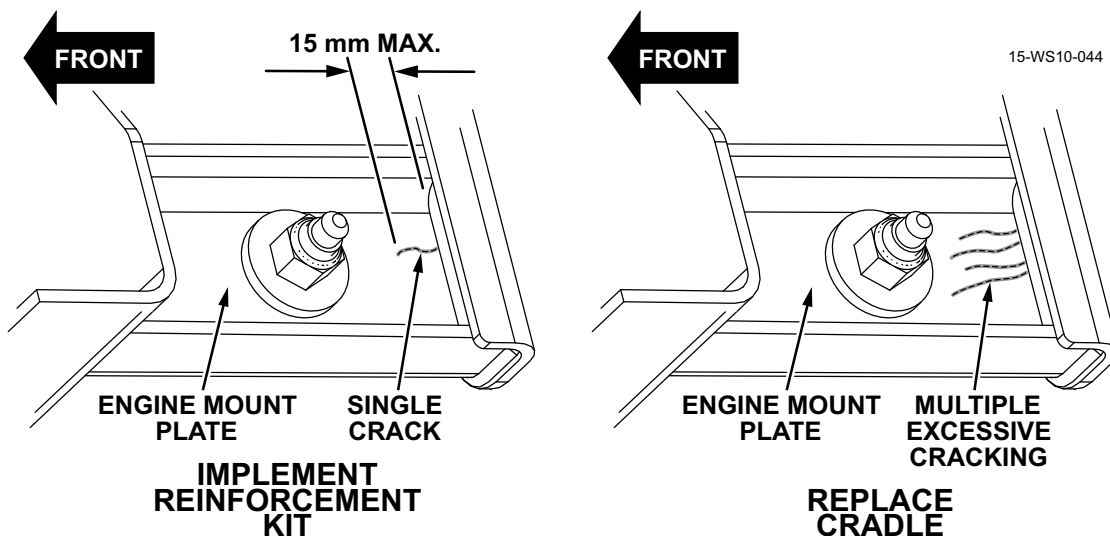

Figure 1: Engine Plate and Bracket Inspection

2. If a single crack is verified of no greater than 15mm, drill-stop at the crack end(s) where accessible with a 3/16" bit. Paint any newly exposed metal and install the reinforcement kit.

Note: It is recommended to coordinate this kit installation with a scheduled Engine Oil and Filter change, as the oil filter must be removed.

3. Remove the Oil Filter. Remove left side Engine Mount nut and set aside for re-installation.
4. Disconnect the Power Steering Lines to the Rack & Pinion. Remove the two Rack & Pinion-to-Cradle bolts and nuts; **do not** disconnect the Tie Rod ends. Lay the Rack & Pinion assembly across the lower control arms (See Figure 2).

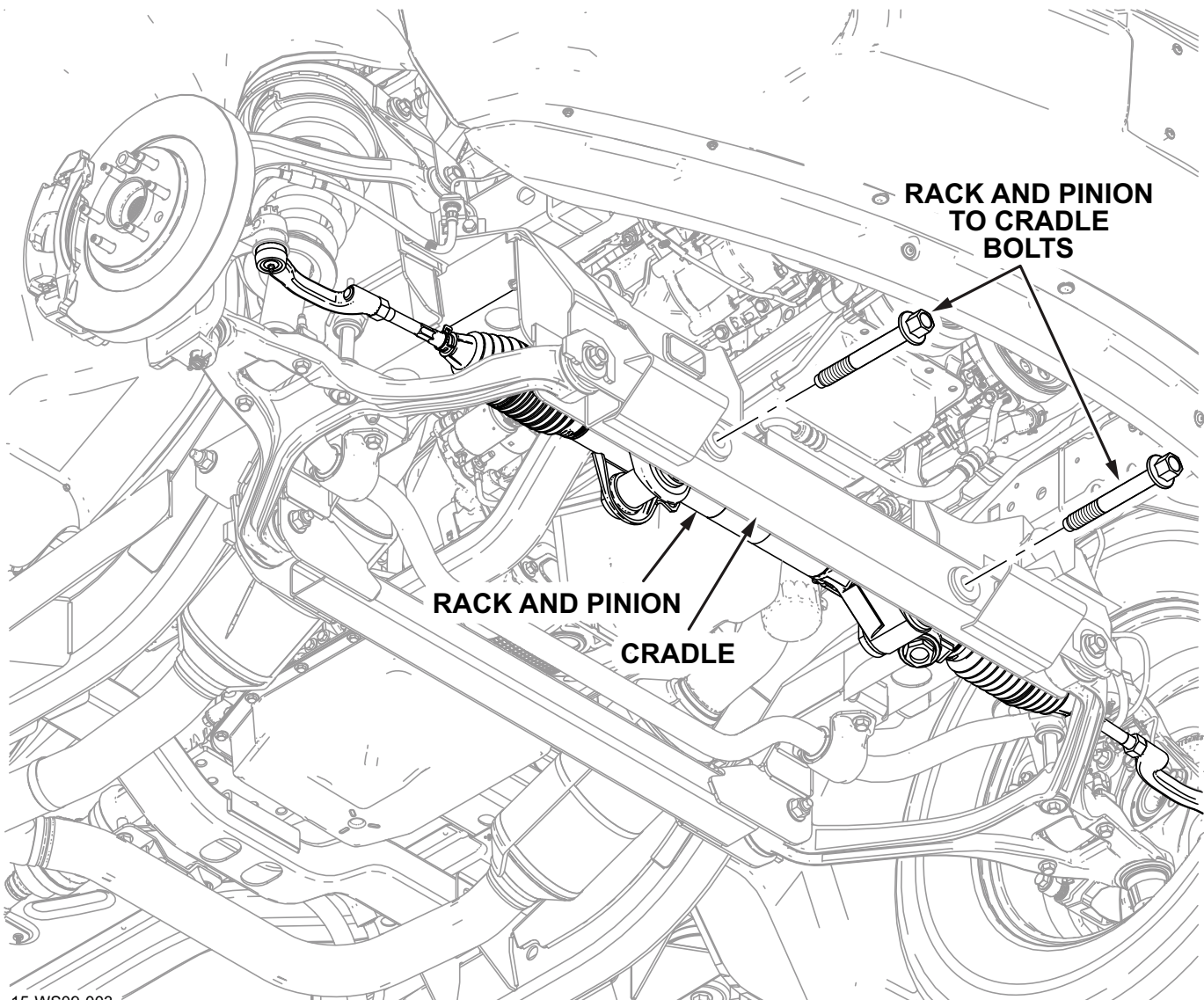

Figure 2: Remove Rack & Pinion Assembly from Crossmember

- Using Front Engine Mount Bracket Template, align the positioning arm against the Engine Mount Plate (See Figure 3). Mark two locations for drilling on the Front Engine Mount Bracket.

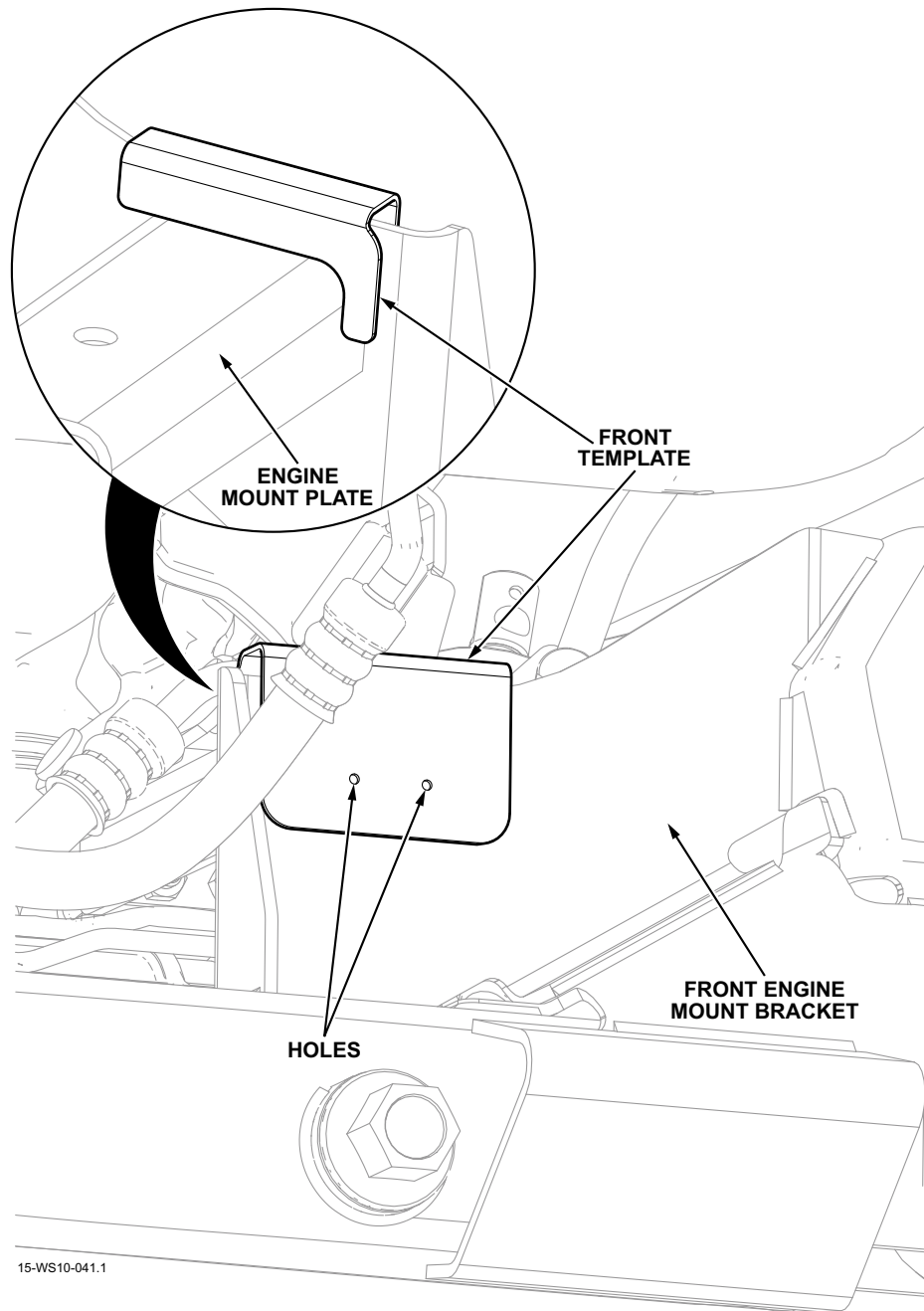
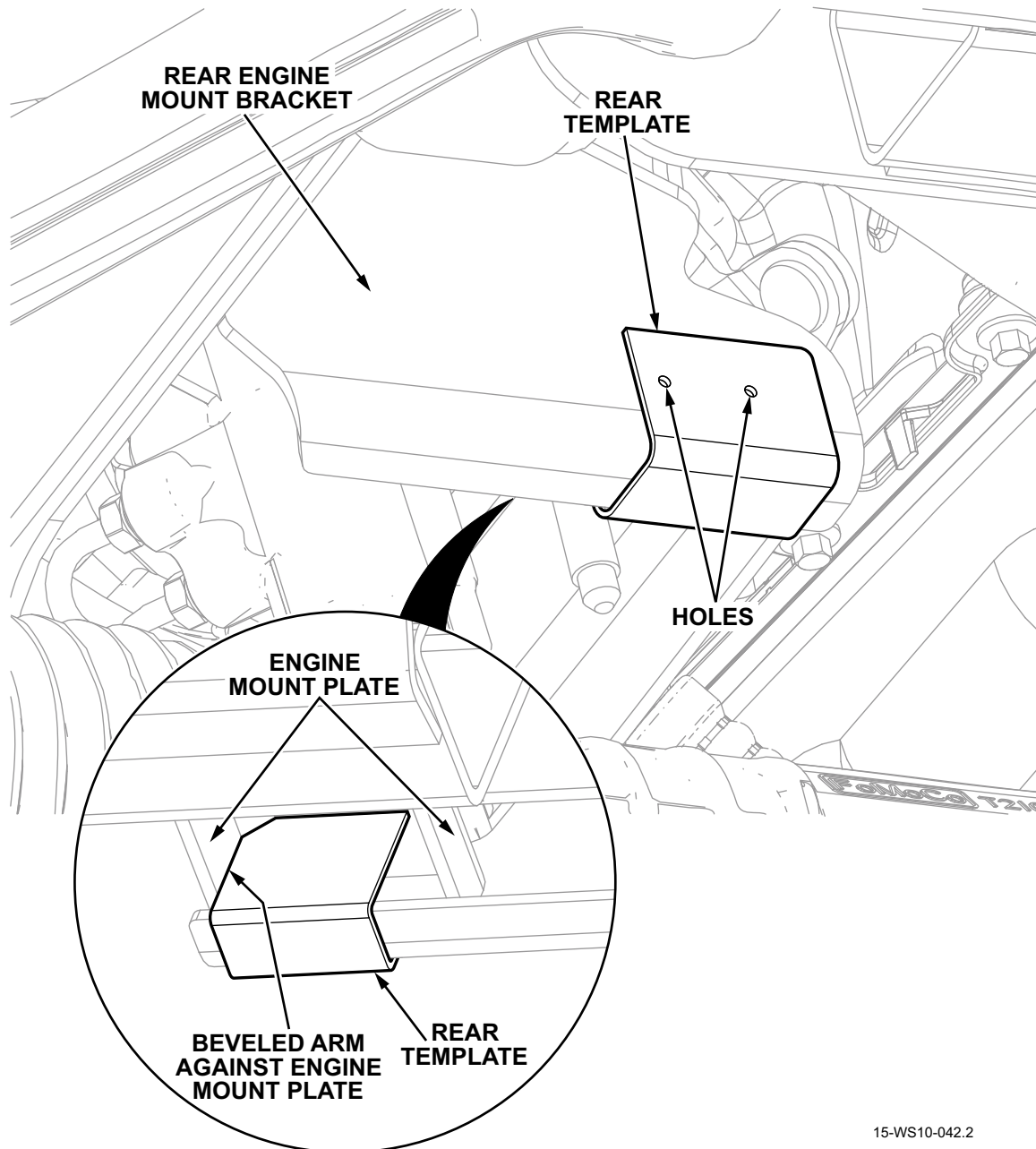

Figure 3: Aligning Template on the Front Left Engine Mount Bracket

- Using a 11/32-inch bit, drill two holes in the front Engine Mount Bracket where marked. Paint any newly exposed metal.

- Using the Rear Engine Mount Bracket Template, align the beveled arm inside and against the Engine Mount Plate (See Figure 4). Mark two locations for drilling on the Rear Engine Mount Bracket.



15-WS10-042.2

Figure 4: Aligning Template on the Rear Left Engine Mount Bracket

- Using a 11/32-inch bit, drill two holes in the rear Engine Mount Bracket where marked. Paint any newly exposed metal.

9. Angle the Reinforcing Cradle Mount Bracket up and against the rear engine mount bracket (lift engine slightly if needed), and align with the holes drilled in the previous steps. Hold against the rear bracket and *lightly secure* with the Engine Mount Nut (See Figure 5).

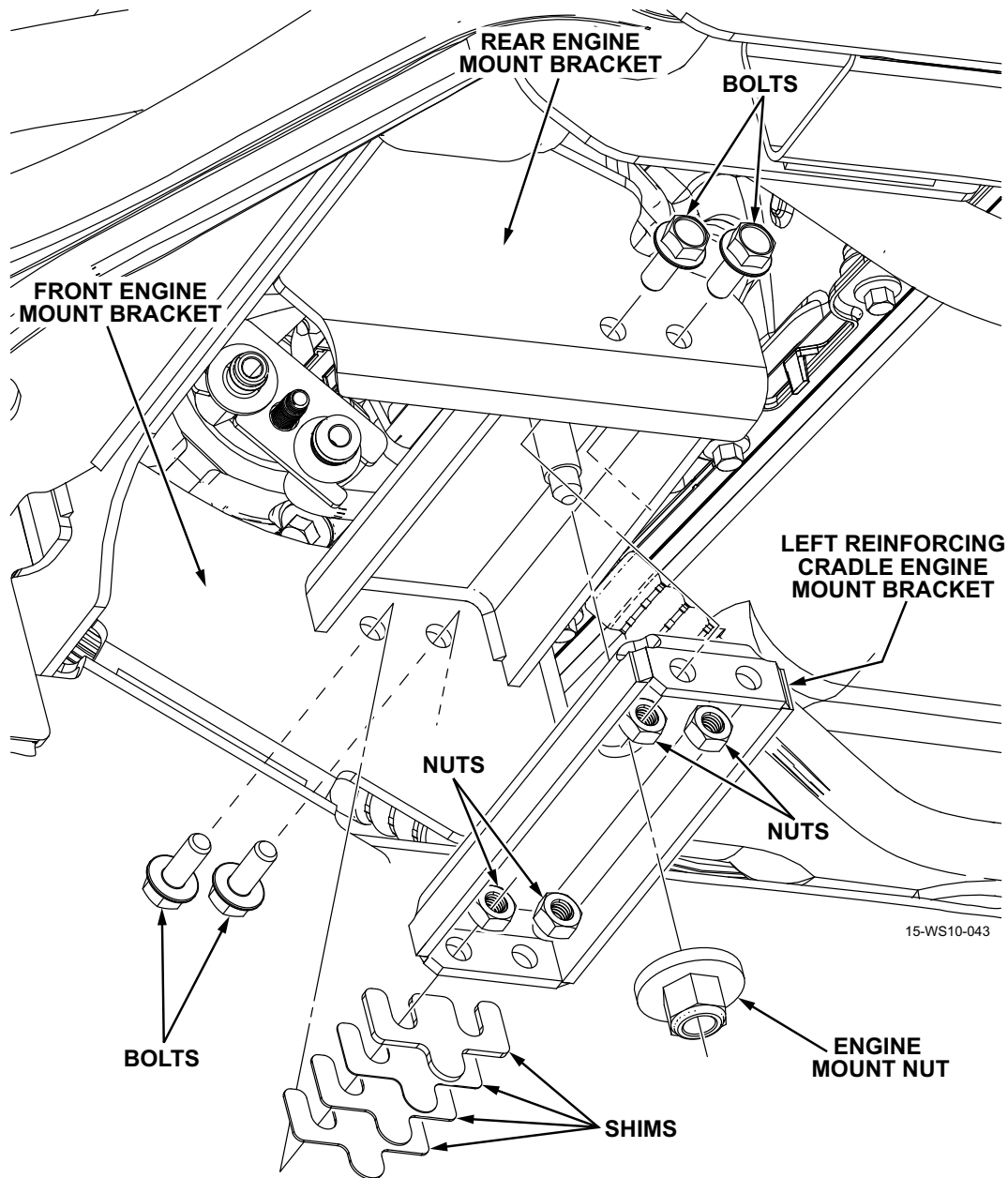

Figure 5: Reinforcing Cradle Mount Bracket Installation

10. Apply high strength thread locking fluid to four bolts and loosely secure the new Reinforcing Bracket to the drilled front and rear engine mount brackets (See Figure 5).
11. Using the supplied shims, insert the necessary mix and quantity between the new Reinforcement Bracket and the front engine mount bracket to eliminate any void.
12. Tighten the original Engine Mount Nut and torque to 85 Nm (63 lb-ft).
13. Tighten the four bracket nuts to 37 Nm (27.3 lb-ft).

14. Install an Oil Filter and replace any removed oil.
15. Install the Rack & Pinion by using the two Steering Rack & Pinion bolts and nuts. Apply medium-strength thread locking fluid and tighten to 440 Nm (325 lb-ft).

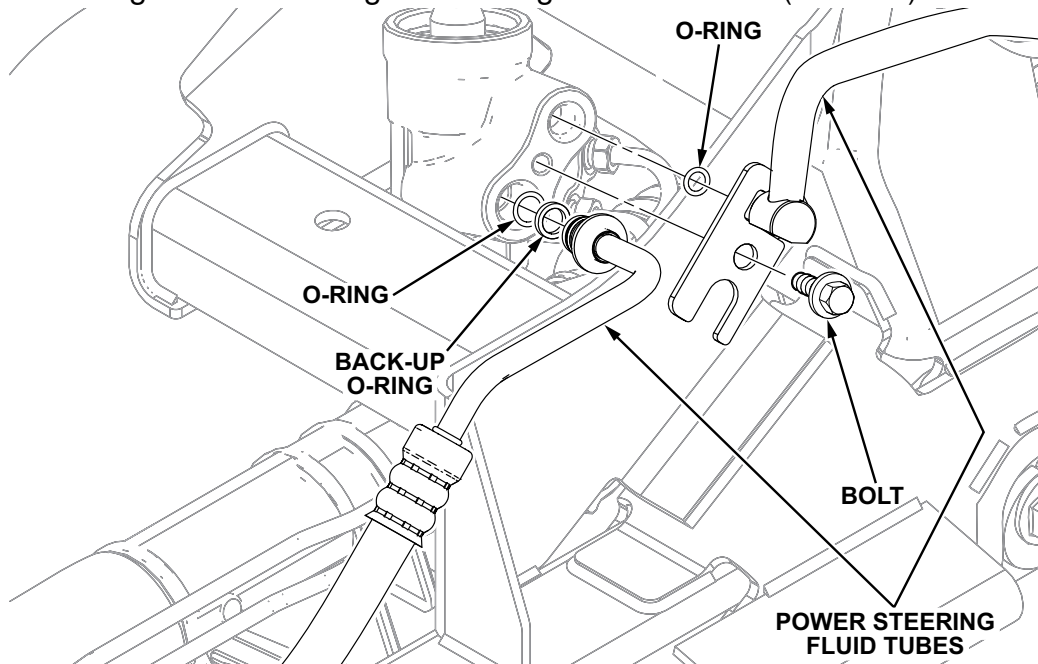

Figure 6: Power Steering Hose Connections

16. Install new O-ring seals on the power steering pressure line and the lower power steering rack-to-cooler hose (See Figure 6).
17. Connect the power steering pressure line and the lower power steering rack-to-cooler hose and install the steering line clamp plate bolt. Torque to 23 Nm (17 lb-ft).
18. Fill the power steering system.
 - Fill the power steering fluid reservoir between the “MIN” and "MAX" level.
 - With the cap off, turn the key to the “ON” position.
 - Raise the vehicle off the ground enough to turn the steering wheel from lock-to-lock repeatedly.
 - Check fluid for air bubbles.
 - Add fluid if necessary.
 - If air bubbles exist, repeat lock-to-lock process
19. Install the reservoir cap and start the vehicle.

NOTE: Repeat this until signs of cavitation or fluid aeration (pump noise/whining) have stopped.

20. Lower the vehicle to the ground and turn steering wheel from lock to lock.
 - Shut the vehicle off.
 - Recheck the fluid levels with the cap/dipstick.
 - Add fluids if necessary.