

# Special Bulletin SB-10060335-6324 SP15-325

Date	Expiration	Release	Page
05.2015	05.2017	1	1(7)

Release 1: This release replaces any previous version  
 May 21, 2015 Part list: added bushing. Images 2 & 3 update. Add image to step 6.

## BI-FOLD DOOR IMPROVEMENTS Prevast vehicles

### DESCRIPTION

On the vehicles affected by this bulletin, perform various improvements on the bi-fold door mechanism.

### MODEL YEAR(S) AND VEHICLES INVOLVED

NOTICE TO SERVICE CENTERS	
Verify vehicle eligibility by checking warranty bulletin status with <b>SAP</b> or via <b>ONLINE WARRANTY SYSTEM</b> available on Service / Warranty tab of Prevast website.	
Model	VIN
X3-45 Commuter Model Year : 2014 - 2015	Single units: 2PCG33495EC735590, 2PCG33498EC735602 From 4RKG33497F9737001 up to 4RKG33499F9737033 incl. And from 4RKG33492F9737035 up to 4RKG33492F9737066 incl.
This bulletin does not necessarily apply to all the above-mentioned vehicles, some vehicles may have been modified before delivery. The owners of the vehicles affected by this bulletin will be advised by a letter indicating the Vehicle Identification Number (VIN) of each vehicle concerned.	

### MATERIAL NEEDED

Order the following parts:

Part No.	Description	Qty
500920	Nylon Washer	1
2800984	Shoulder Screw 16mm Dia. ; M12 x 1.75, Xylan Coated.	4

Other parts that may be required:

Part No.	Description	Qty
685072	Thread Locker Loctite #243 / Blue / 5ml	1
642228	Cylinder end bushing	1
-	Torque Seal Paint Tube, Yellow	1

<b>NOTE</b>
Material can be obtained through regular channels.



## DANGER

Park vehicle safely, apply parking brake, stop engine. Prior to working on the vehicle, set the ignition switch to the OFF position and trip the main circuit breakers equipped with a trip button. On Commuter type vehicles, set the battery master switch (master cut-out) to the OFF position.

- 1) Locate the front entrance door on the vehicle.(Fig. 1)

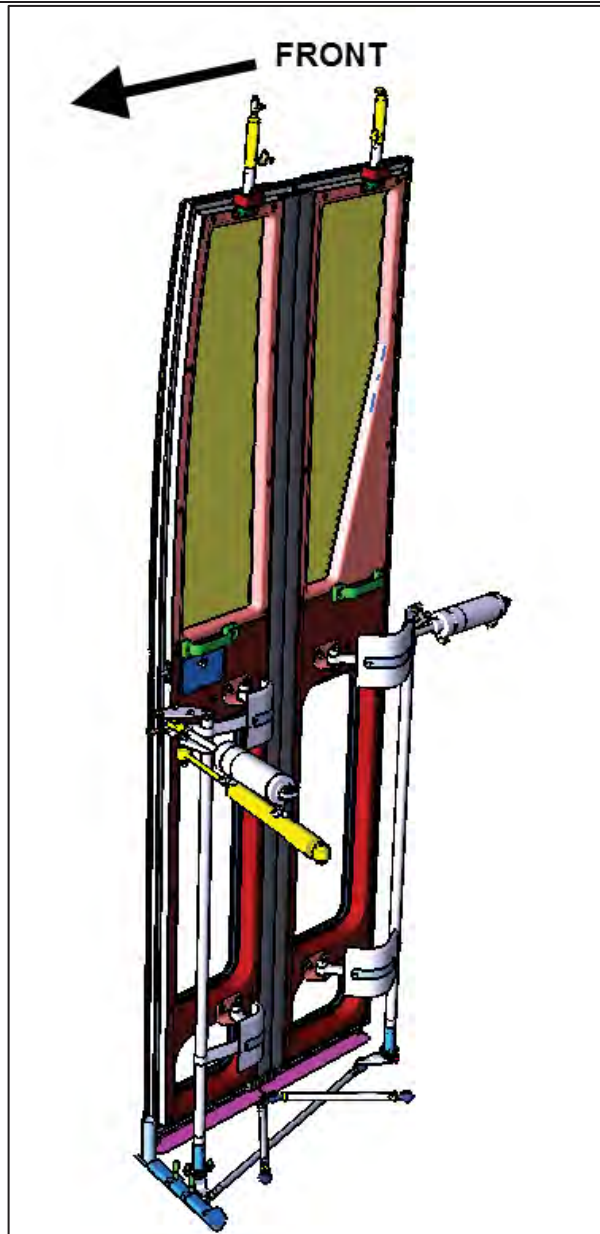

Figure 1

**TORQUE REFERENCE.** *Do not tighten hardware yet!* This will be performed further in the bulletin.

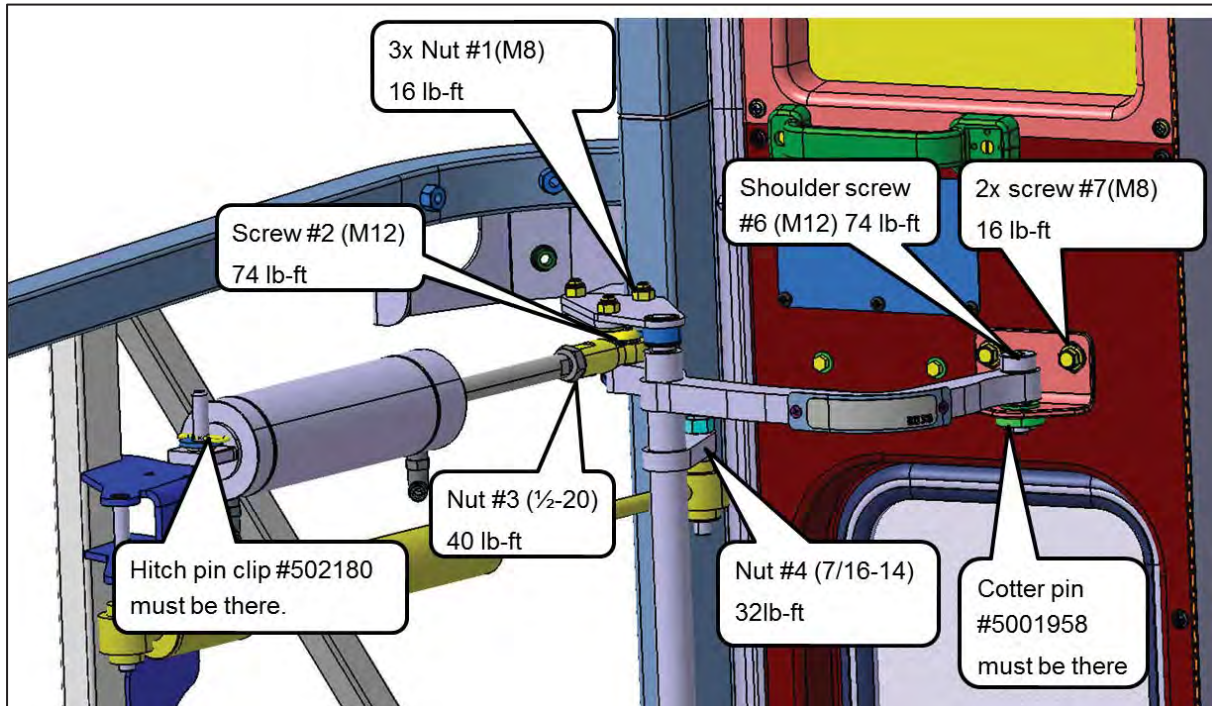

Figure 2 Torque reference, fore door links

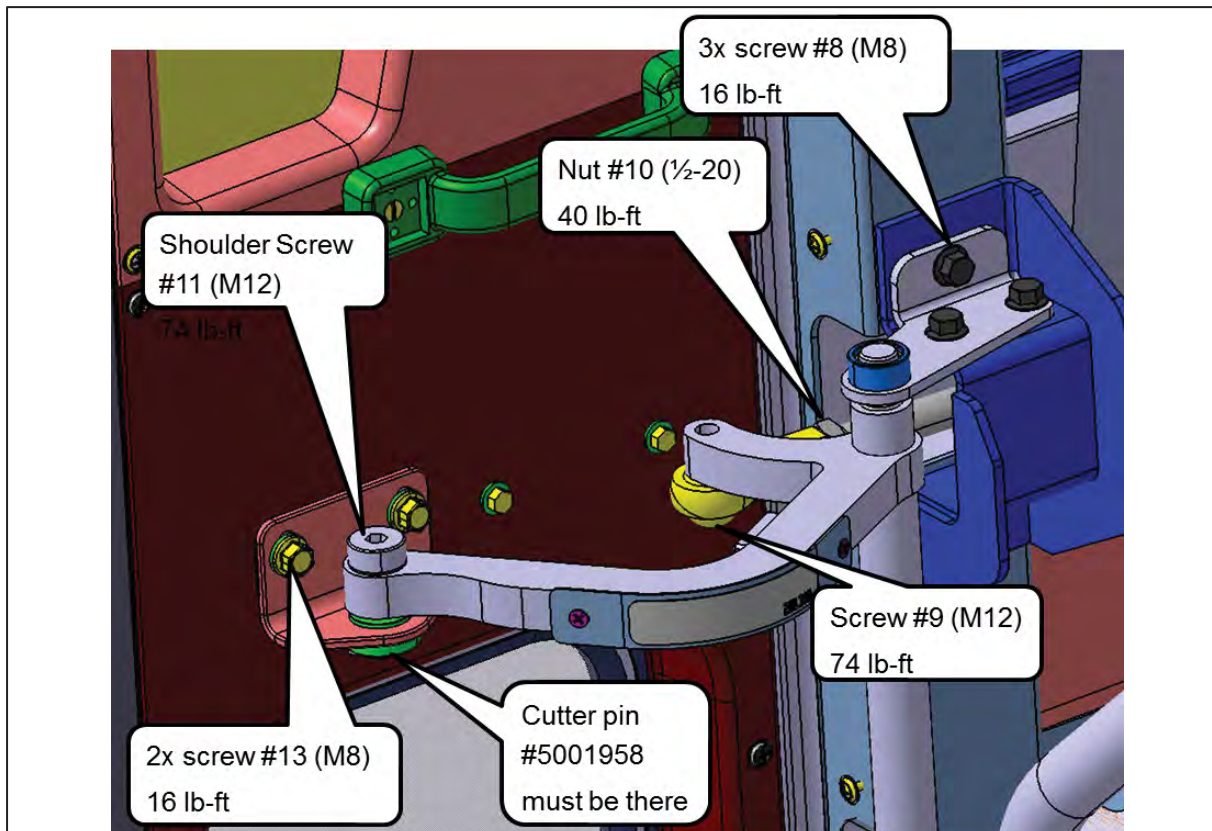

Figure 3 Torque reference, aft door links

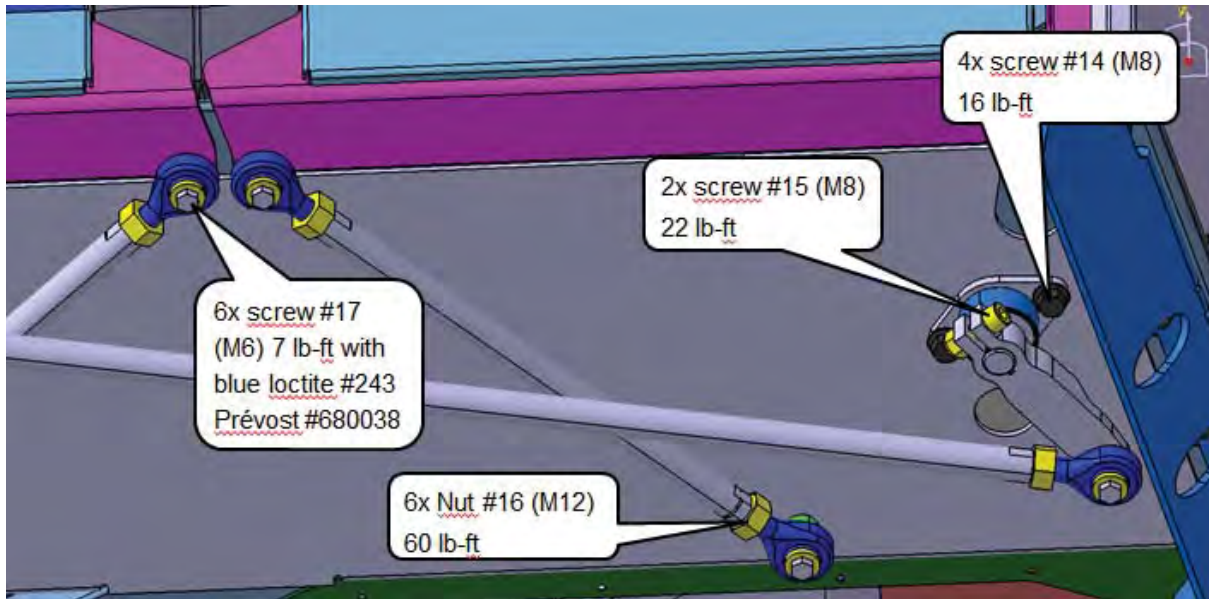

Figure 4 Torque reference, bottom linkage

- 1) On fore and aft cylinder, adjust rod end to dimension shown in fig. 5.
- 2) On fore and aft air cylinders, tighten rod end nut to **40 lbf-ft**. Apply torque seal.

(#3,fig. 2) ; (#10 fig. 3)

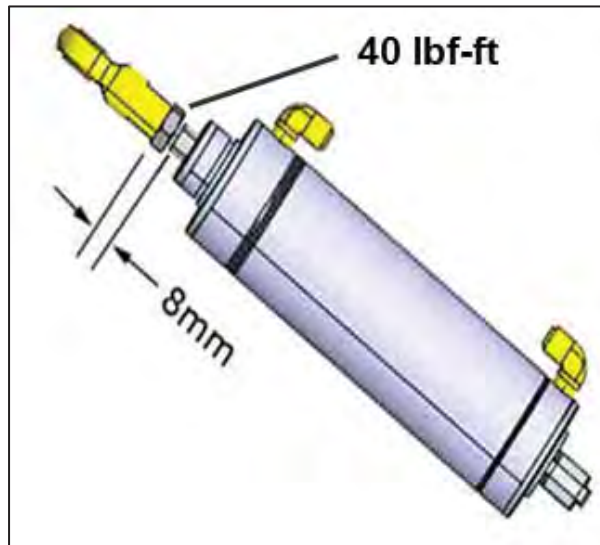

Figure 5

- 3) Remove the fore cylinder completely. Reserve hardware for re-assembly.
- 4) Inspect the cylinder bushing for any signs of looseness or damage. Replace with #642228 if required. (Fig. 6)

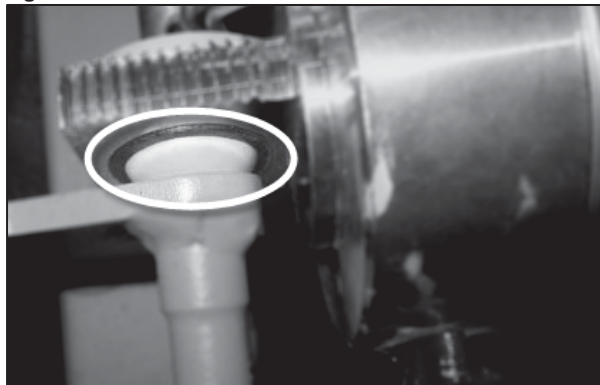

Figure 6

Date	Expiration	Release	Page
05.2015	05.2017	1	5(7)

- 5) Re-assemble cylinder frame side anchor adding a washer under the anchor. (Arrow, Fig. 7)

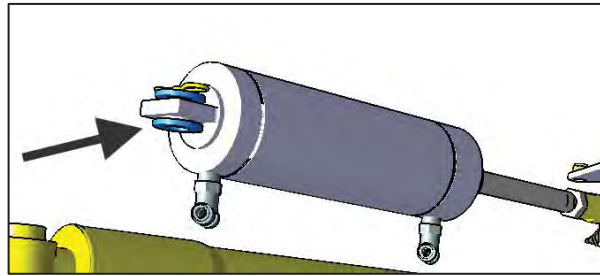

Figure 7

- 6) Tighten shoulder screw on door side to **74 lbf-ft.** (fig. 8 & #2, fig. 2).

Apply torque seal.



Figure 8

Date	Expiration	Release	Page
05.2015	05.2017	1	6(7)

7) On the damper pivot, loosen the assembly and re-tighten in the appropriate sequence. (Fig. 9)

Tighten both items to **32 lbf-ft.** (#4, fig. 2)  
Apply torque seal.

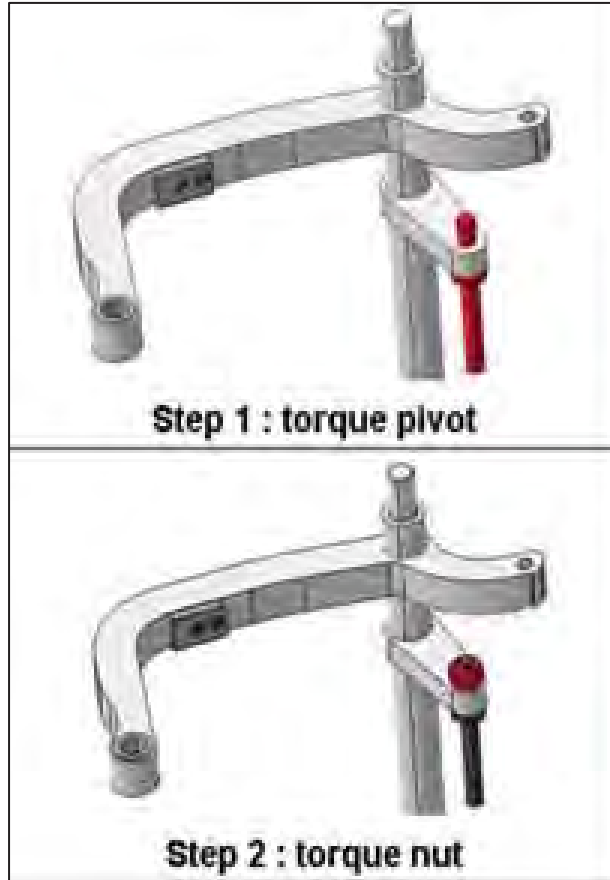

Figure 9

8) Inspect the door stopper to make sure it is oriented properly. (Fig. 10)

(Long edge towards the curve of the arm)

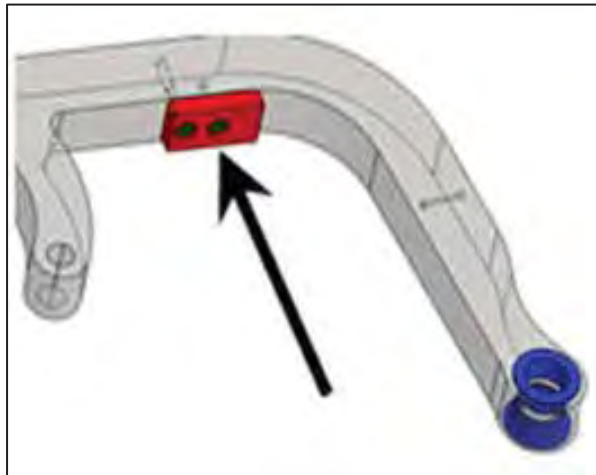

Figure 10

Date	Expiration	Release	Page
05.2015	05.2017	1	7(7)

9) ONLY FOR UNITS UP TO 7040

Items # 6, fig. 2 and #11, fig. 3:

Change the existing screw for# 2800984.(Qty:4) Tighten to **74 lbf-ft.** Apply torque seal.

10) Finally, tighten each item shown in Torque Reference Figures 2, 3 and 4, with the exception of the items already tightened so far in the bulletin. Apply torque seal.

## PARTS / WASTE DISPOSAL

Discard waste according to applicable environmental regulations (Municipal/State[Prov.]/ Federal)
---

## ESTIMATED TIME

The time required to perform this special bulletin is approximately two hours.

## OTHER

VBC Bulletin	N/A
Fail Code	18.01
Defect Code	09
System Condition	B
Causal Part	500920

Prevost engages in a continuous program of testing and evaluating to provide the best possible product. Prevost, however, is not committed to, or liable for updating existing products.